

AD-1653

INSTRUCTION MANUAL

DENSITY DETERMINATION KIT

Applicable analytical balance models

BM series
GH series
HR-i series
GR series
HR series
HA series

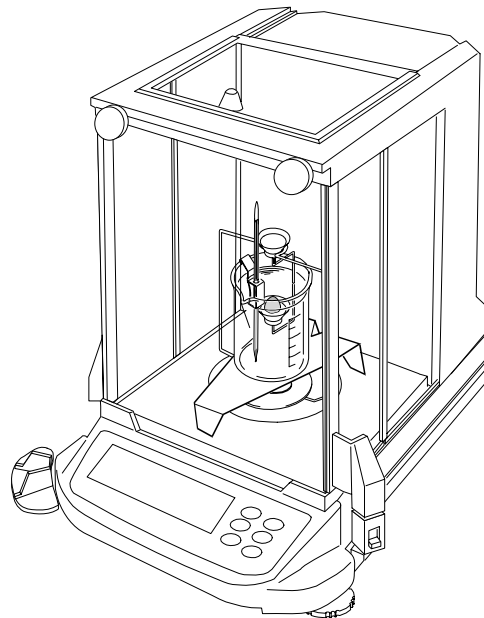

A&D

A&D Company, Limited

1WMPD4000728B

© 2012 A&D Company, Limited. All rights reserved.

No part of this publication may be reproduced, transmitted, transcribed, or translated into any language in any form by any means without the written permission of A&D Company, Limited.

The contents of this manual and the specifications of the instrument covered by this manual are subject to change for improvement without notice.

CONTENTS

1.	INTRODUCTION	2
1.1.	Precautions	2
2.	UNPACKING THE KIT	3
3.	DENSITY MEASUREMENT PRINCIPLES	4
3.1.	Density	4
3.2.	Specific Gravity	4
3.3.	Archimedes' Principle of Density Measurement.....	4
3.4.	Density of a Solid	5
3.5.	Density of a Liquid	5
4.	ERROR FACTORS	6
4.1.	Buoyancy of Air	6
4.2.	Volume of Float.....	6
4.3.	Temperature of Liquid	7
4.4.	Influence of Wire	7
4.5.	Surface Tension	7
4.6.	Bubbles	7
5.	MEASURING THE DENSITY OF A SOLID	8
5.1.	Assembling the Kit: BM / GH / HR-i Series.....	8
5.2.	Assembling the Kit: GR Series	9
5.3.	Assembling the Kit: HR Series	10
5.4.	Assembling the Kit: HA Series.....	11
5.5.	Measuring the Density of a Solid	12
6.	MEASURING THE DENSITY OF A LIQUID.....	14
6.1.	Assembling the Kit:	14
6.2.	Measuring the Density of a Liquid.....	15
7.	FREQUENTLY ASKED QUESTIONS	16

1. INTRODUCTION

Thank you for purchasing the AD-1653 Density Determination Kit.

This manual describes how to use the AD-1653 Density Determination Kit.

The AD-1653, when combined with one of our electronic balances (BM series, GH series, HR-i series, GR series, HR series and HA series), allows the density of a solid and liquid to be measured easily.

Before using the AD-1653, please read this manual thoroughly and keep it at hand for future reference.

1.1. Precautions

- This density determination kit allows the density of a solid or liquid to be measured. However, the results of measurements may be affected by various factors that could cause errors, and thus we can not guarantee these results.
- Do not use the density determination kit for measuring the density of chemically active substances.
- After using the density determination kit, clean all surfaces to remove rust and oxides.
- A balance is a precision instrument. Avoid shocks and excessive loads.
- Maintain the air, sample and liquid at a constant temperature during the measurement.

2. UNPACKING THE KIT

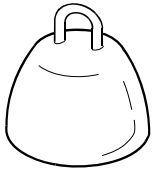

Float
B44342



Diameter of 0.2 mm

Wire
B49799

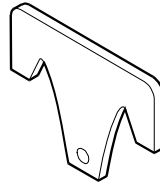

Float hook
C42200

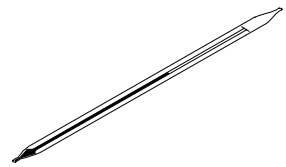

Thermometer
B44813

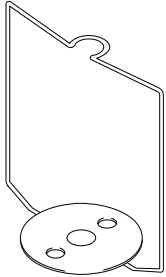

Density pan stand
B31161

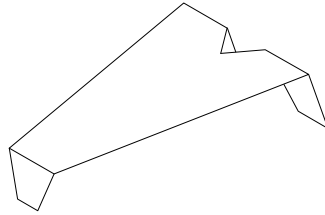

Beaker stand
B31158



Beaker
PYLEX-300ML

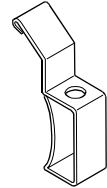

Thermometer clamp
1-608-02

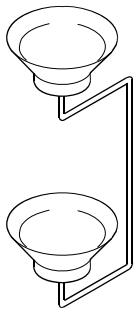

Density pan
1653-1

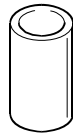

Attachment for FX (obsolete product)
C42219



Attachment for HX (obsolete product)
C42220

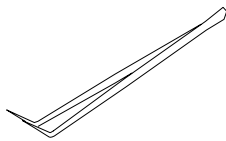

Tweezers
SHIKAYO

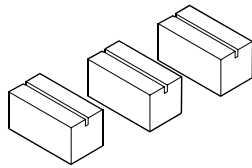

Beaker stand spacer
C42223 (3 pcs)

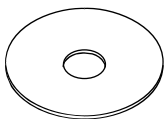

Balance weight (small)
B48920

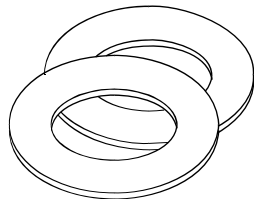

Balance weight (large)
C43701 (2 pcs)

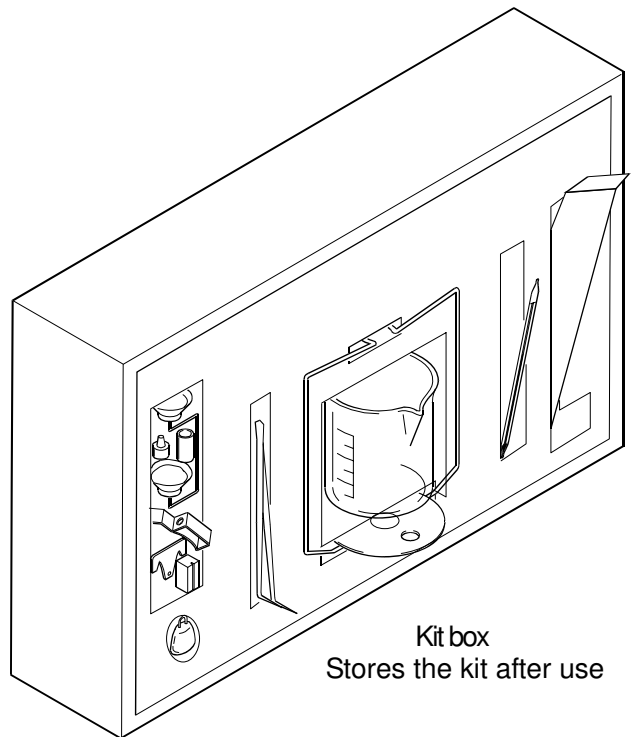

Kit box
Stores the kit after use

3. DENSITY MEASUREMENT PRINCIPLES

3.1. Density

Density refers to the total mass of a sample per unit volume.

$$\rho = \frac{M}{V} \quad (\text{Unit: g/cm}^3, \text{ etc.})$$

ρ : Density

M : Mass

V : Volume

3.2. Specific Gravity

Specific gravity refers to the ratio of the density of a sample to the density of pure water at 4°C under a pressure of 1013.25 hPa.

$$\rho = \frac{M}{V \cdot \rho_4} \quad (\text{No unit})$$

ρ : Specific gravity

M : Mass

V : Volume

ρ_4 : Density of water at 4°C

(0.99997 g/cm³ ≈ 1.000 g/cm³)

3.3. Archimedes' Principle of Density Measurement

The AD-1653 is combined with an electronic balance to measure the density of a sample based on the Archimedes' principle.

Archimedes' principle

A body immersed in a liquid (or a gas) is subject to an upward force equal to the weight of the liquid (or the gas) it displaces. The upward force is buoyancy.

3.4. Density of a Solid

The density of a solid can be obtained according to the weight of the sample in air, the weight of the sample in liquid and the density of the liquid.

$$\rho = \frac{A}{A - B} \times (\rho_0 - d) + d$$

ρ : Density of sample

A : Weight of sample in air

B : Weight of sample in liquid

ρ_0 : Density of liquid

d : Density of air (approx. 0.001 g/cm³)

3.5. Density of a Liquid

To measure the density of a liquid, a float with a known volume is used.

The density of a liquid can be obtained according to the weight of the float in air, the weight of the float in liquid and the volume of the float.

$$\rho = \frac{A - B}{V} + d$$

ρ : Density of liquid

A : Weight of float in air

B : Weight of float in liquid

V : Volume of float

d : Density of air (approx. 0.001 g/cm³)

4. ERROR FACTORS

There are several things that can affect the accuracy of a density measurement.

4.1. Buoyancy of Air

- A density measurement is influenced by an upward force of 0.0010 to 0.0014 g/cm³ (buoyancy of air).
- The density of air can be obtained by the equation below:

$$d = \frac{0.0012932}{1 + 0.0036728 \times t \text{ (}^\circ\text{C)}} \times \frac{P \text{ (hPa)}}{1013.25}$$

d : Density of air (g/cm³)

t : Air temperature (°C)

P : Atmospheric pressure (hPa)

- When measurement accuracy of three significant digits is necessary, add 0.001 g/cm³ to the measured value to compensate for the error due to the air density.

4.2. Volume of Float

- The tolerance of the measured value of the volume of the float is ±0.01 cm³.
In liquid density measurement, the decimal places beyond the second decimal place of the measured value contain errors.
- When measurement accuracy to the third decimal place or beyond is necessary, measure the volume of the float using distilled water.

$$V = \frac{A - B}{\rho - d} - 0.0035$$

V : Volume of float (cm³)

A : Weight of float in air (g)

B : Weight of float in liquid (g)

ρ : Density of distilled water at t°C (g/cm³)

d : Buoyancy of air at t°C (g/cm³)

0.0035 : Correction value for the wire (diameter of 1 mm) of the density pan connecting the upper and lower pans (when the beaker provided with this kit is used)

4.3. Temperature of Liquid

- The density of the liquid that is used for measuring the density of a solid varies with the liquid temperature. Therefore, the decimal places beyond the first decimal place of the measured value contain errors.
- Obtain the density of a liquid according to the temperature from Table 1 for distilled water or from other reference documents for other liquids.
- When measurement accuracy to the third decimal place or beyond is necessary, use a thermometer with a tolerance of $\pm 0.2^{\circ}\text{C}$ or less.

4.4. Influence of Wire

- In solid density measurement, the surface of the liquid rises when a solid sample is placed on the density pan, which is immersed in the liquid. At this time, the buoyancy corresponding to the weight of the raised liquid is exerted on the wire (diameter of 1 mm) connecting the upper and lower pans. If the surface of the liquid rises 1 mm, the buoyancy exerted on the wire is about 0.8 g/cm^3 . To minimize the error due to the buoyancy, select a sample with a smaller volume or correct the value by calculation.
- In liquid density measurement, a force (buoyancy) is exerted on the wire (diameter of 0.2 mm) suspending the float, when immersed in the liquid. Immersing the wire by 10 mm exerts a buoyancy of about 0.3 mg on the wire. However, this buoyancy influence can be ignored. When obtaining the liquid density, the difference between the weight of the float in air and in water is divided by the volume of the float, as described in “3.5. Density of a Liquid”. This calculation reduces the error due to buoyancy such that it is negligible.

4.5. Surface Tension

- In solid density measurement, a force (surface tension) of about 5 mg is exerted on the pan between the wire (diameter of 1 mm) of the density pan and the liquid surface.
- The surface tension can be reduced by about 1 mg by adding a surfactant (for example, a wetting agent used for developing photographs.)
Adding 0.1 mL (density: 1.2 g/cm^3) of a surfactant to 200 mL of water will increase the density of water by about 0.0001 g/cm^3 .
- In liquid density measurement, a force (surface tension) of about 1 mg is exerted on the wire (diameter of 0.2 mm) suspending the float. However, this surface tension influence can be ignored. When obtaining the liquid density, the difference between the weight of the float in air and in water is divided by the volume of the float, as described in “3.5. Density of a Liquid”. This calculation reduces the error due to surface tension such that it is negligible.

4.6. Bubbles

- The buoyancy of a bubble of 1 mm in diameter is about 0.5 mg. Bubble generation depends on the shape and material of the sample, so take care when making measurements.
- In solid density measurement, a surfactant may be added to reduce the influence of bubbles.

5. MEASURING THE DENSITY OF A SOLID

Assemble the kit as described in the procedure below. Note that the assembly procedure depends on the balance model.

5.1. Assembling the Kit: BM / GH / HR-i Series

Note: The kit can not be used with the BM-20 and BM-22 of the BM series balances.

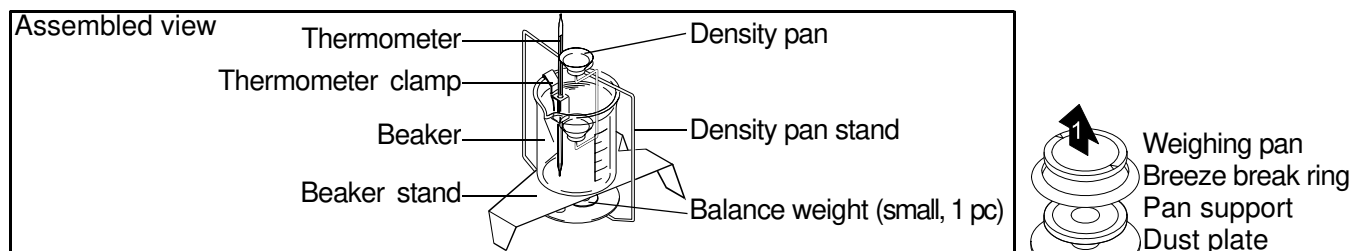

1. Remove the weighing pan, pan support, breeze break ring and dust plate from the balance.
2. Place the density pan stand on the balance.
3. Place one balance weight (small) on the density pan stand.
4. Place the beaker stand so that it does not touch the density pan stand.
5. Attach the thermometer clamp to the beaker and insert the thermometer into the thermometer clamp.
6. Pour a liquid with a known density (such as distilled water) into the beaker and place the beaker on the beaker stand.
7. Place the density pan on the density pan stand.
8. Adjust the amount of the liquid so that the sample, when placed on the lower pan (in the liquid), is about 10 mm below the surface of the liquid.
9. When the value displayed on the balance is stable, press the **RE-ZERO** key to set the displayed value to zero.

Now the balance is ready for density measurement.

Note: The BM and GH series balances are equipped with a density mode to calculate the density of a solid.

For details, refer to the instruction manual of each series.

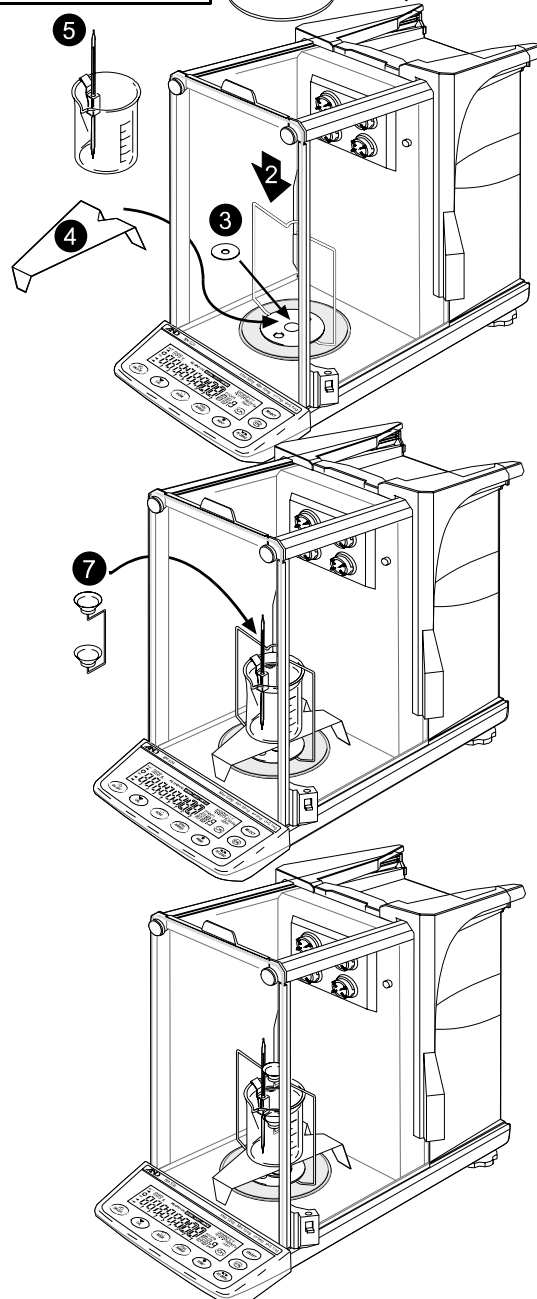

Example: BM series

5.2. Assembling the Kit: GR Series

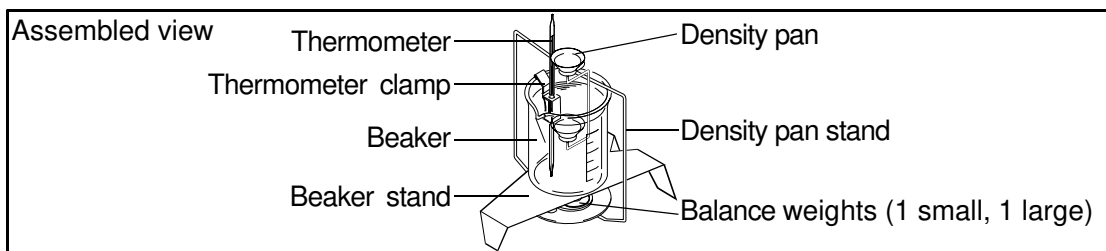

1. Remove the weighing pan and breeze break from the balance.
2. Place the density pan stand on the balance.
3. Place one small balance weight and one large balance weight on the density pan stand.
4. Place the beaker stand so that it does not touch the density pan stand.
5. Attach the thermometer clamp to the beaker and insert the thermometer into the thermometer clamp.
6. Pour a liquid with a known density (such as distilled water) into the beaker and place the beaker on the beaker stand.
7. Place the density pan on the density pan stand.
8. Adjust the amount of the liquid so that the sample, when placed on the lower pan (in the liquid), is about 10 mm below the surface of the liquid.
9. When the value displayed on the balance is stable, press the **RE-ZERO** key to set the displayed value to zero.

Now the balance is ready for density measurement.

Note: The GR series balance is equipped with a density mode to calculate the density of a solid.
For details, refer to the instruction manual of GR series.

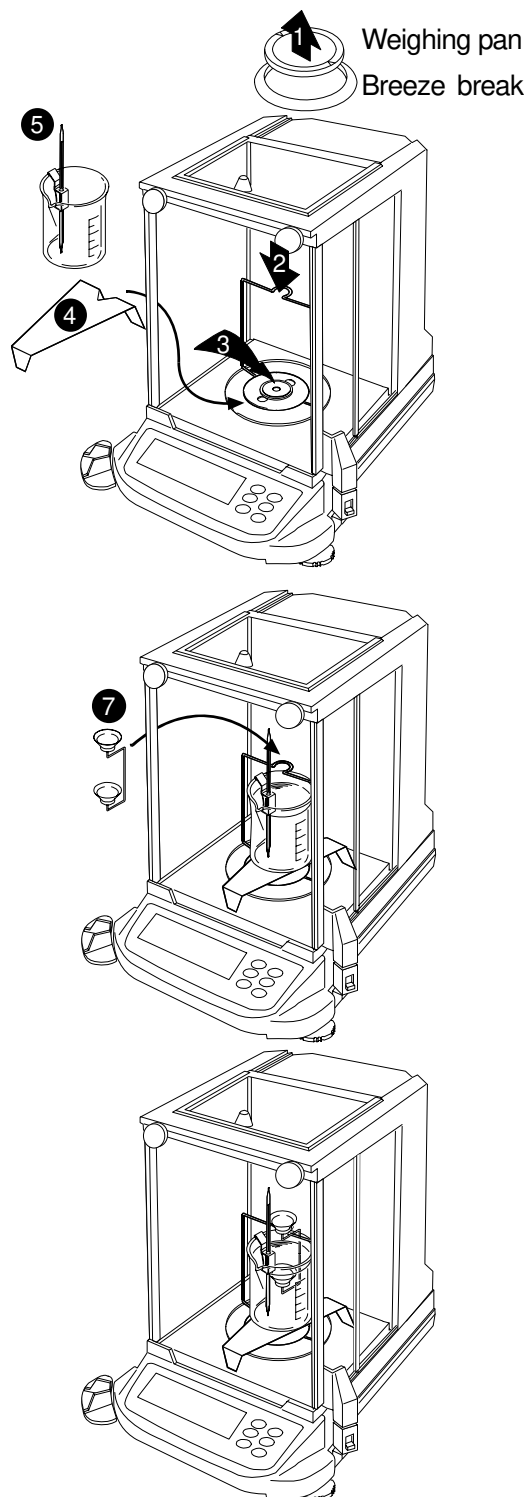

5.3. Assembling the Kit: HR Series

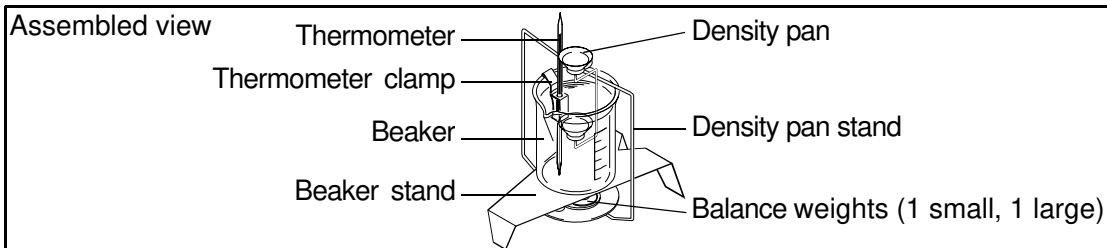

1. Remove the weighing pan and breeze break from the balance.
2. Place the density pan stand on the balance.
3. Place one small balance weight and one large balance weight on the density pan stand.
4. Place the beaker stand so that it does not touch the density pan stand.
5. Attach the thermometer clamp to the beaker and insert the thermometer into the thermometer clamp.
6. Pour a liquid with a known density (such as distilled water) into the beaker and place the beaker on the beaker stand.
7. Place the density pan on the density pan stand.
8. Adjust the amount of the liquid so that the sample, when placed on the lower pan (in the liquid), is about 10 mm below the surface of the liquid.
9. When the value displayed on the balance is stable, press the **RE-ZERO** key to set the displayed value to zero.
10. When **-E** or **-----** is displayed on the balance, perform a zero calibration.

Now the balance is ready for density measurement.

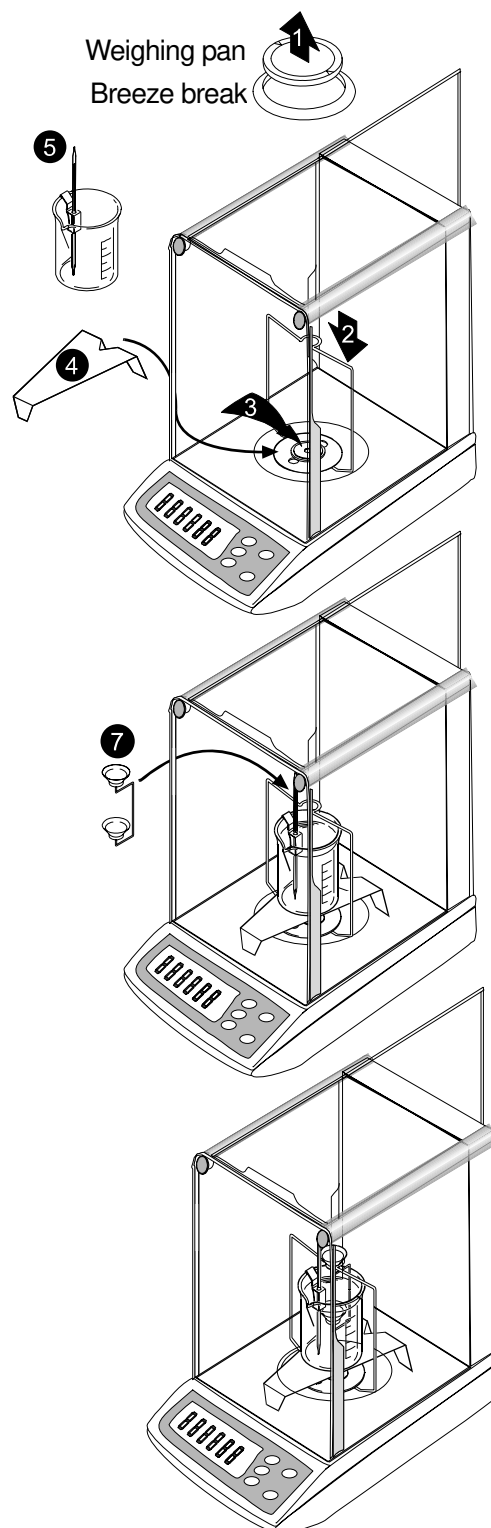

5.4. Assembling the Kit: HA Series

Note: Do not use the front door to open or close the balance.

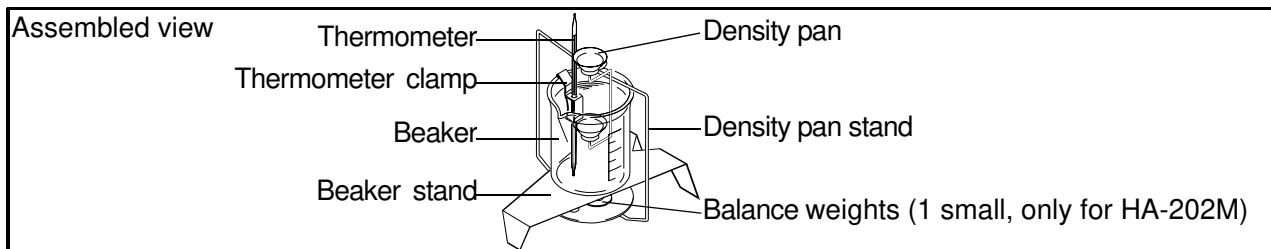

1. Remove the weighing pan, balance weight, pan support, breeze break ring and dust plate from the balance.

2. Place the density pan stand on the balance.

3. (Only for HA-202M)
Place one balance weight (small) on the density pan stand.

4. Place the beaker stand so that it does not touch the density pan stand.

5. Attach the thermometer clamp to the beaker and insert the thermometer into the thermometer clamp.

6. Pour a liquid with a known density (such as distilled water) into the beaker and place the beaker on the beaker stand.

7. Place the density pan on the density pan stand.

8. Adjust the amount of the liquid so that the sample, when placed on the lower pan (in the liquid), is about 10 mm below the surface of the liquid.

9. When the value displayed on the balance is stable, press the **RE-ZERO** key to set the displayed value to zero.

Now the balance is ready for density measurement.

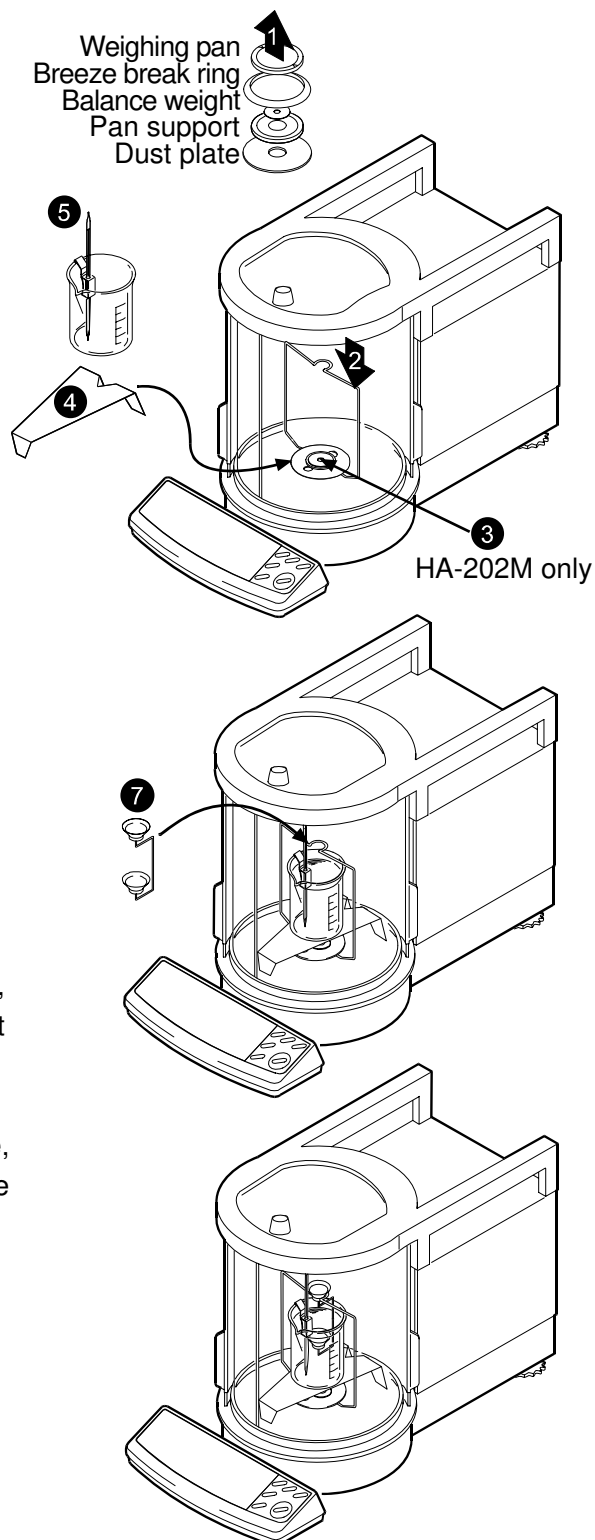

5.5. Measuring the Density of a Solid

- The density of a solid is obtained by averaging the measured values.

1. Start the measurement when water temperature becomes stable.
2. Press the **RE-ZERO** key to set the displayed value to zero.
3. Place the sample on the upper pan and record its weight in air (A).
4. Press the **RE-ZERO** key to set the displayed value to zero.
5. Place the sample on the lower pan and record its weight in water (B). At this time, ignore the minus sign.

Note: Make sure that the sample is about 10 mm below the surface of the liquid.

6. Obtain the density of water according to the temperature. (Refer to Table 1.)

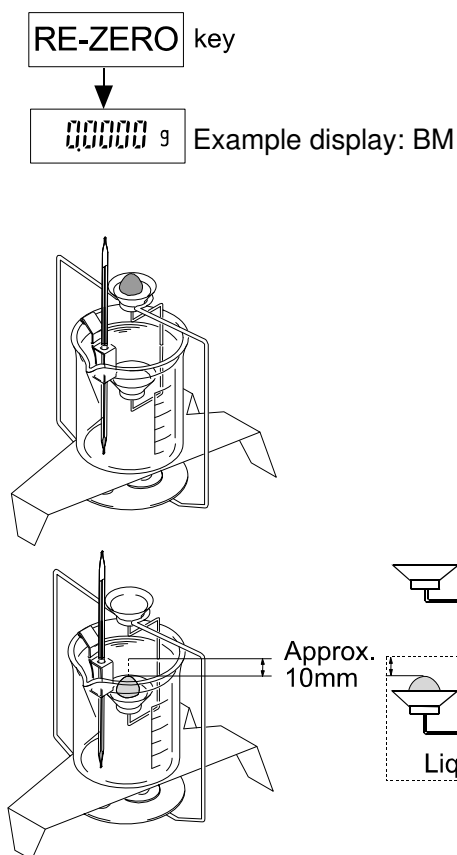

Table 1 Density of distilled water (Unit: g/cm³)

Temp. (°C)	+0	+1	+2	+3	+4	+5	+6	+7	+8	+9
0	0.99984	0.99990	0.99994	0.99996	0.99997	0.99996	0.99994	0.99990	0.99985	0.99978
10	0.99970	0.99961	0.99949	0.99938	0.99924	0.99910	0.99894	0.99877	0.99860	0.99841
20	0.99820	0.99799	0.99777	0.99754	0.99730	0.99704	0.99678	0.99651	0.99623	0.99594
30	0.99565	0.99534	0.99503	0.99470	0.99437	0.99403	0.99368	0.99333	0.99297	0.99259
40	0.99222	0.99183	0.99144	0.99104	0.99063	0.99021	0.98979	0.98936	0.98893	0.98849
50	0.98804	0.98758	0.98712	0.98665	0.98618	0.98570	0.98521	0.98471	0.98422	0.98371
60	0.98320	0.98268	0.98216	0.98163	0.98110	0.98055	0.98001	0.97946	0.97890	0.97834
70	0.97777	0.97720	0.97662	0.97603	0.97544	0.97485	0.97425	0.97364	0.97303	0.97242
80	0.97180	0.97117	0.97054	0.96991	0.96927	0.96862	0.96797	0.96731	0.96665	0.96600
90	0.96532	0.96465	0.96397	0.96328	0.96259	0.96190	0.96120	0.96050	0.95979	0.95906

At sea level (1 atmosphere), the density of water reaches maximum at 3.98°C.

7. Use the following equations to obtain the density.

- Three significant digits

$$\rho = \frac{A}{|B|} \times \rho_0$$

- Four or more significant digits

$$\rho = \frac{A}{|B|} \times (\rho_0 - d) + d$$

ρ : Density of sample (g/cm³)

A : Weight in air

B : Weight in water

ρ_0 : Density of water

d : Density of air (g/cm³)

Example of recording sheet

Weight in air (A) (g)	Weight in water (B) (g)	Water temperature (°C)	$\frac{(\text{Weight in air: A})}{ \text{Weight in water: B} } \times (\text{Water density})$ (g/cm ³)
4.8102	0.5946	26	8.06 (Calculated value)
		Water density (g/cm ³)	
		0.99678	

Weight in air (A) (g)	Weight in water (B) (g)	Water temperature (°C)	Atmospheric pressure (hPa)	$\frac{(\text{Weight in air: A})}{ \text{Weight in water: B} } \times (\text{Water density} - \text{Air density}) + \text{Air density}$ (g/cm ³)
4.8102	0.5946	26		8.055 (Calculated value)
		Water density (g/cm ³)	Air density (g/cm ³)	
		0.99678	0.0012	

6. MEASURING THE DENSITY OF A LIQUID

Assemble the kit as described in the procedure below.

6.1. Assembling the Kit:

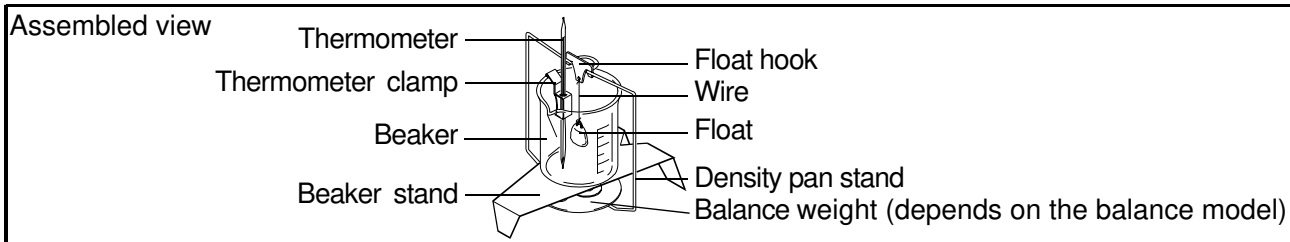

1. For the procedure up to the setting of the beaker stand, refer to the assembly procedure for each balance model described in “5. MEASURING THE DENSITY OF A SOLID”.
2. Attach the thermometer clamp to the beaker and insert the thermometer into the thermometer clamp.
3. Place the beaker on the beaker stand.
4. Connect the float to the float hook using the wire. The length of wire must be about 50 mm.
5. Hook the float hook on the density pan stand.
6. When the value displayed on the balance is stable, press the **RE-ZERO** key to set the displayed value to zero.

Now the balance is ready for density measurement.

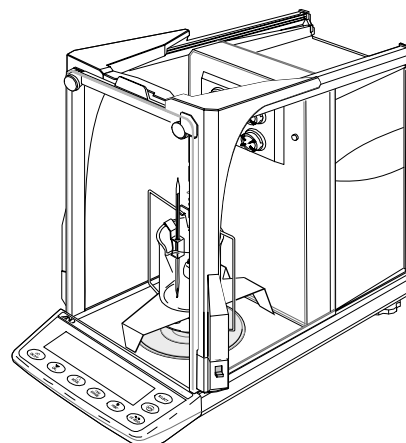
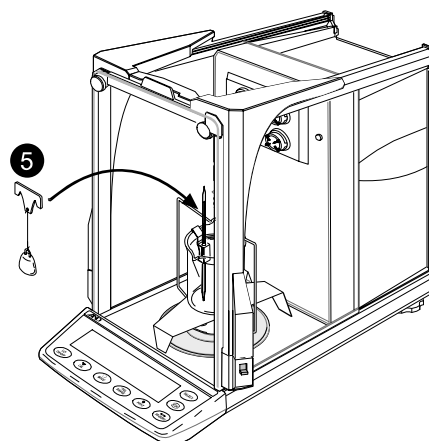
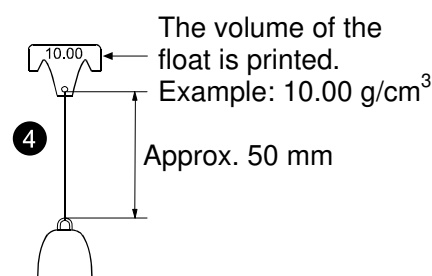

6.2. Measuring the Density of a Liquid

- Use the following procedure to obtain the density of a liquid.

1. With the float hanging, press the **RE-ZERO** key to set the displayed value to zero.
2. Pour the liquid of which you want to measure the density into the beaker.

Note: Make sure that the float is about 10 mm below the surface of the liquid.

3. When the value displayed on the balance is stable, record the value (A). At this time, ignore the minus sign.
4. Substitute the measured value in the following equation to obtain the density of the liquid.

$$\rho = \frac{|A|}{V} + d$$

- ρ : Density of liquid (g/cm³)
- A : Buoyancy of float (g)
- V : Volume of float (g/cm³)
- d : Density of air (g/cm³)

Example: If the measured value (A) is 9.9704 g, the volume of the float (V, printed on the float hook) is 10.00 g/cm³, the density of air (d) is 0.001 g/cm³ and the temperature indicated by the thermometer is 25°C, then the density value is:

$$\frac{9.9704}{10.00} + 0.001 = 0.998 \text{ g/cm}^3 (25^\circ\text{C})$$

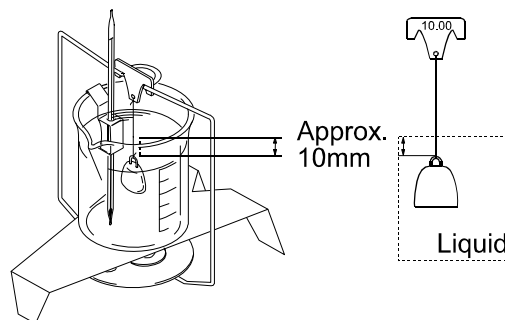
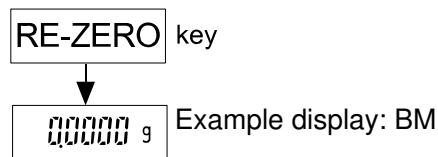

7. FREQUENTLY ASKED QUESTIONS

Questions	Answers						
I'd like to measure the density of a resin pellet or sheet, which floats in water. Is it possible?	Use a liquid that has a lower density than water and does not dissolve the sample, such as methanol (density 0.798) or kerosene (density 0.80). The density of the liquid used is measured using the float provided with the kit.						
Can a sample containing bubbles be measured?	The density of a sample with bubbles can be measured as it is. But as time passes, the bubbles disappear and the apparent density may change. A sample that floats in water due to the low density can not be measured.						
The measurement repeatability may be affected by the water's surface tension. What can I do about this?	A few drops of a surfactant (for example, a mild detergent for washing dishes) added to the water reduce the influence of surface tension. A few drops of a surfactant will affect the liquid density only a very small amount. When methanol is used in place of water, the influence of surface tension is small, even without a surfactant.						
When tap water is used, bubbles are gradually generated on the sample surface and a measurement error occurs. What can I do about this?	Tap water contains dissolved gases such as oxygen and carbon dioxide. When tap water is used, the released dissolved gases generate bubbles. It is recommended that pure water or distilled water, which contains few dissolved gases, be used.						
When I try to measure a highly water-repellent material such as rubber, bubbles stick to the sample. What can I do about this?	Before measurement, soak the sample in the water with an appropriate amount of surfactant added. Doing this increases the sample surface hydrophilicity and makes it more difficult for bubbles to stick to the sample surface.						
Up to what size of sample can be measured?	In consideration of the density pan size, the maximum sample size that can be measured is: <table style="margin-left: auto; margin-right: auto;"> <tr> <td style="padding-right: 20px;">Diameter</td> <td>25 mm</td> </tr> <tr> <td>Height</td> <td>30 mm</td> </tr> <tr> <td>Mass</td> <td>100 g</td> </tr> </table>	Diameter	25 mm	Height	30 mm	Mass	100 g
Diameter	25 mm						
Height	30 mm						
Mass	100 g						
Can I measure the density of a liquid with a high viscosity?	A liquid with a viscosity up to 500 mPa·s can be measured. If the viscosity exceeds this value, the float takes excessive time to sink and a measurement error occurs. Measuring adhesive is not recommended because the adhesive sample may be difficult to remove from the float.						
Does using a semi-micro balance improve accuracy?	The effects of surface tension cause errors in the measurement value of around 0.2 to 1.0 mg. In measurement using the 0.1 mg range, the magnitude of error and the level of balance accuracy are almost the same. In measurement using the 0.01 mg range, the magnitude of error greatly exceeds the level of balance accuracy, so using a semi-micro balance is not recommended.						

AND