

A photograph of a laboratory freezer with its door open, showing interior shelves. The image is overlaid with a semi-transparent grey rectangle containing the title text. Blue vertical bars are on the left and right sides of the image.

ULTRA LOW TEMPERATURE FREEZERS

Models:

MDF-DU502VH-PE | MDF-DU702VH-PE

MDF-U33V-PE | MDF-U55V-PE

MDF-DU901VHL-PE

MDF-C8V1-PE

PHCbi's VIP Ultra Low Temperature Freezers represent the industry's most complete combination of refrigeration technology, control, alarm, monitoring and accessibility for reliable sample preservation.

ULTRA LOW TEMPERATURE FREEZERS



VIP ECO Upright Freezers

528 litres Freezer (up to 384 2"boxes)
729 litres Freezer (up to 576 2"boxes)
845 litres Freezer (up to 672 2"boxes)

MDF-DU502VH-PE
MDF-DU702VH-PE
MDF-DU901VHL-PE



VIP Upright Freezers

333 litres Freezer (216 2"boxes)
519 litres Freezer (352 2"boxes)

MDF-U33V-PE
MDF-U55V-PE



VIP Chest Freezer

84 litres Freezer (42 2"boxes)

MDF-C8V1-PE

EXCELLENT RELIABILITY AND UNIFORMITY WITHIN AN OPTIMAL FOOTPRINT.

The refrigeration systems within PHCbi VIP freezers are designed specifically for demanding ultra low temperature applications to give proven durability. Manufactured with space-saving VIP vacuum insulation panels, they are ideally suited for use in laboratories and hospitals for long-term preservation of samples. Whatever your preservation needs are, PHCbi provides the right equipment for your application.



Performance & quality you can trust

Scientific Applications

Reliable long-term preservation of:

- Tissues and cells
- DNA, RNA and proteins
- Blood products
- Biological samples
- Clinical trial materials
- Pharmaceutical products

Stable temperatures for:

- Quality control
- Temperature testing
- Fatigue testing

MEDICAL DEVICE DIRECTIVE

MDF-U55V, MDF-DU502VH and MDF-DU702VH Freezers are certified as a Class IIa Medical Device (93/42/EEC and 2007/47/EC) for medical purposes of storing cells, tissues, organs and embryos.



Medical Device Directive

PHCbi has become one of the first companies in our industry to introduce Medical Device certification to underline our strong commitment to product design, quality and safety.

In 2010, PHCbi was awarded certification by TÜV-Süd to manufacture blood bank refrigerators, freezers and incubators as Class IIa Medical Devices according to the directives 93/42/EEC and 2007/47/EC. At the same time our quality systems were updated to the latest ISO9001 and ISO13485 standards.

The use of refrigeration products and cell culture incubators for the preservation and cultivation of cells and tissues for human use in transfusion, regenerative medicine and cell therapy is set to expand.





VIP ULT Freezers

PHCbi DESIGN & ULTIMATE RELIABILITY

VIP ultra low temperature freezers offer advanced cabinet design, reliable refrigeration systems and easy-to-use controllers making them ideal for the long-term secure storage of valuable samples. Every component is carefully selected and matched for optimum operation under demanding laboratory conditions, while the internal layout of the refrigeration system is meticulously designed for maximum heat removal, reducing stress on the system and therefore providing the highest levels of reliability and durability.

SUPERIOR PERFORMANCE

All PHCbi freezers are designed to provide the highest quality construction with superior performance. Key features such as strategically placed evaporator coils, VIP panels and insulated inner doors contribute to the unrivalled temperature uniformity and stability of VIP freezers, allowing the freezers to conform to the strictest standards and validation protocols. Quieter operation is achieved through condenser fan blade design, noise reduction insulation, anti-vibration systems and internal compressor noise reduction.

EFFICIENT COOLING

Cascade refrigeration systems within the VIP upright freezers provide efficient cooling with optimized heat exchange pathways and increased cooling capacity for reliable sample protection and cost effective operation at ultra low temperatures.

ENHANCED USE & INTELLIGENT SECURITY

Our freezers are managed and monitored by an integrated microprocessor controller with a comprehensive alarm system and diagnostic functions. A Status Alert feature constantly monitors ambient and system conditions and notifies the user of any abnormalities before a problem occurs. The MDF-DU901VHL-PE is updated with a touch screen that allows full user control, even with gloved hands, and a USB port for convenient transfer of logged data to a PC.

SUPERIOR FOOTPRINT

PHCbi ultra low temperature freezers with space-saving VIP insulation offer outstanding energy efficiency, whilst delivering exceptional cooling performance and durability for storing valuable research and clinical samples.

VIP INSULATION



The combination of multiple high-performance vacuum panels with high-density foam insulation provides a reduced wall thickness for maximum interior volume.

VIP PLUS INSULATION



PHCbi's patented VIP PLUS technology has resulted in a revolutionary vacuum insulation cabinet construction with improved thermal properties for superior temperature performance.

INNOVATIVE DESIGN

PHCbi was the first company to introduce vacuum insulation panels to ultra low temperature freezers. The PHCbi patented VIP vacuum insulation panel thin-wall composite is a high-efficiency design that yields more interior storage volume in a conventional freezer footprint. The PHCbi VIP Freezer range typically provide 30% more storage capacity for a given floor area saving valuable laboratory space.

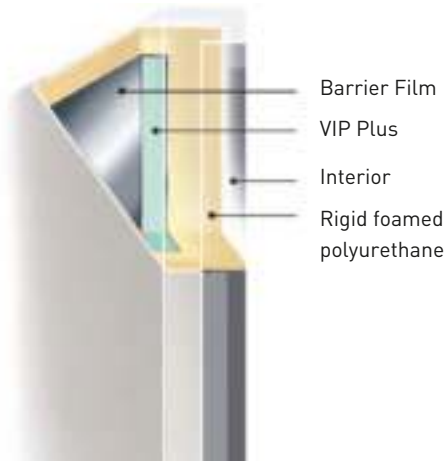

WHICH FREEZER WILL YOU CHOOSE?

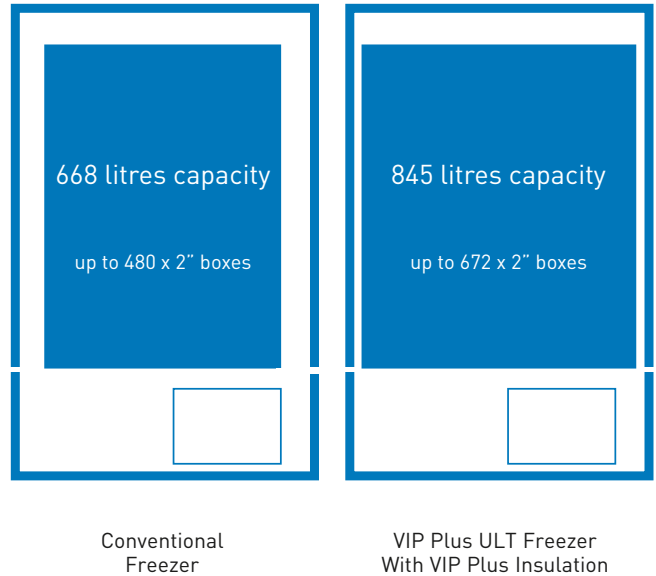

OPTIMUM UNIFORMITY

Uneven interior temperatures can lead to a loss in sample integrity. PHCbi freezers with uniform, stable temperatures and quick recovery times provide the best protection for your samples, ensuring reliable preservation while guarding against degradation.

Surpasses the customer preference of +/-5°C*

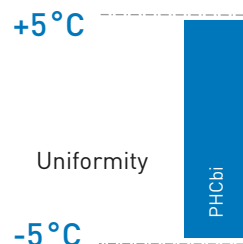

* Based on internal validation data tested at -80°C setpoint, in an empty chamber with 23°C ambient temperature.

* The data may vary depending on the use, circumstances and optional accessories. Validation documents can be provided for each serial number for an additional fee.

CASCADE COOLING SYSTEM

Low Stage Capillary Tube.
Liquid refrigerant under pressure is passed through the capillary tube where it evaporates in the low stage evaporator to absorb energy (heat) from the product stored in the freezer.

Freezer Cabinet with Evaporator.
The evaporator coil is strategically wrapped around to provide optimum temperature uniformity within the freezer cabinet.

Capillary tube between high and low stage
Low stage capillary tube heat exchanger provides optimum heat transfer between high and low temperature points in the low stage leading to greater energy efficiency (With the exception of MDF-U33V, MDF-C8V1).

Low Stage Compressor.
The compressor pumps refrigerant through the low stage circuit.

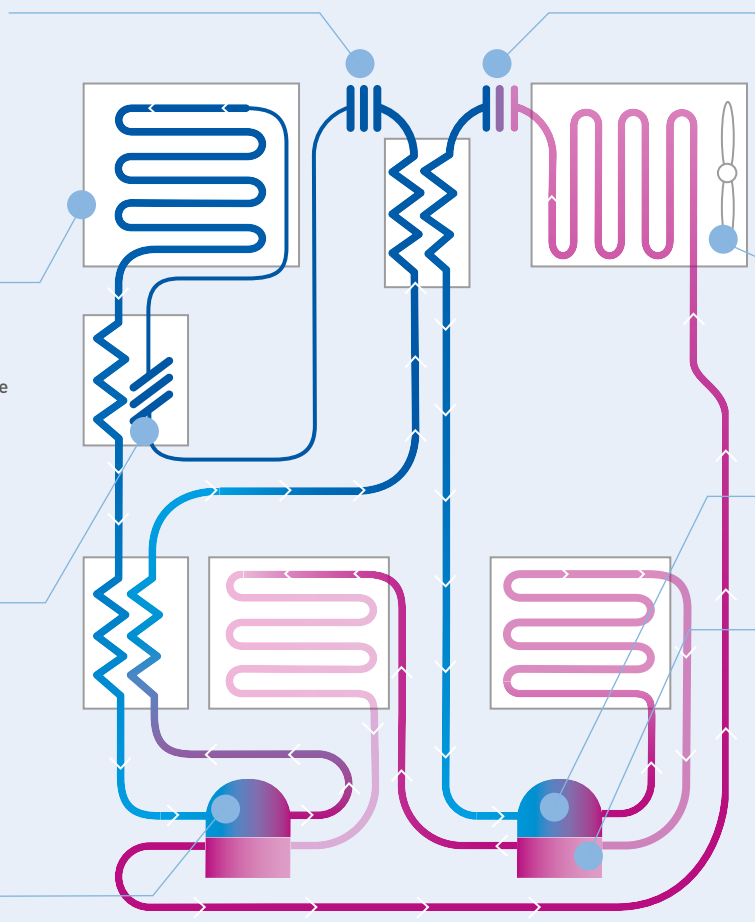

High Stage Capillary Tube.
Liquid refrigerant under pressure is passed through the capillary tube where it evaporates in the interstage heat exchanger to absorb energy (heat) from the low stage refrigerant circuit.

Main Condenser and Motor/Fan Assembly.
PHCbi's exclusive triple pass forced air condenser increases overall system efficiency by providing maximum surface area for heat rejection.

High Stage Compressor.
The compressor pumps refrigerant through the high stage circuit.

High Stage Oil Heat Exchanger.
PHCbi exclusive. High stage refrigerant passes through the high stage oil sump to cool the lubricating oil increasing the reliability of the high stage compressor.

Sensors (Not Shown).

Temperature sensors throughout the high and low stage circuits transmit information to the PHCbi controller for operation, monitoring, interpretation and component protection.

Ultra low temperature refrigeration systems can be extremely demanding with high operating pressures, increased temperatures and stresses and adverse effects on lubricant oil.

PHCbi refrigeration systems are specifically designed for their application. Two of the most important concepts in designing a superior energy saving ultra low freezer are the heat exchange pathways and the compressors:

- By providing optimum heat exchange pathways in the design, it not only increases efficiency of the system, leading to greater energy savings, but it will also have an effect of reducing stress on the compressors leading to greater overall system reliability. PHCbi's new capillary tube heat exchanger is the latest step in increasing the available heat exchange areas in the system.
- The compressors used within the VIP freezers are designed with special features to ensure low running temperatures. This reduces stress on the overall system for extremely reliable operation and exceptional durability.

- 1 Multiple access ports permit insertion of independent probes, instrumentation or liquid CO₂ back-up injectors.
- 2 Universal keyed door lock offers added security.
- 3 A vacuum release port (available on the MDF-DU502VH-PE, MDF-DU702VH-PE and the MDF-DU901VHL-PE allows smooth door opening when the door seal is tightened by negative pressure generated from temperature difference between chamber and ambient.
- 4 Insulated and gasketed inner doors seal inside to offer additional protection, improve uniformity.
- 5 EZlatch for smooth, one-handed operation and positive gasket seal. Provision for padlock.
- 6 Temperature recorder (optional) mounts easily in pre-engineered mounting space.
- 7 PHCbi designed compressors are specifically designed for ultra low temperature applications.
- 8 High impact, recessed casters and leveling feet simplify installation.
- 9 An integrated microprocessor controller with LCD Touch Screen to simplify all freezer functions.
- 10 Front access to washable, electrostatic condenser filter for routine condenser air filter cleaning.
- 11 Heated outer door gaskets and a 'hot line' circulating hot refrigerant gas around the door frame ensure minimal ice build-up.



Model: MDF-DU702VH-PE

EZlatch



The new EZLatch door handle on the MDF-DU502VH, MDF-DU702VH and MDF-DU901VHL-PE makes access to stored samples even easier. Designed to open with minimal effort and repeatedly stress tested to ensure endurance.



VIP SERIES MONITORING

Digital display defaults to actual chamber temperature. Display mode changes when set-point, alarm parameters, programming, and diagnostic functions are performed.

PHCbi exclusive Ni-MH battery powers control memory and alarm functions during power failure.

Filter indicator lamp glows, when electrostatic filter requires removal for cleaning.

Alarm indicator lamp glows when freezer is in alarm condition. Alarm ringback is factory set for 30 minutes, adjustable in 10 minute increments from 10 to 60 minutes.

Door alarm indicator has 2 minute delay until audible alarm activates. Delay time is adjustable.

Status alert function uses predictive intelligence to determine if freezer is operating within specifications under existing environmental conditions.

Set-point entry advances digital display to next value from 0 to 9.

Set-point entry advances digital display to next position.

Press to set temperature; set button is also used for other diagnostic functions.

Buzzer silence temporarily mutes audible alarm.

Alarm test verifies readiness of alarm function and Ni-MH battery charge.

Adjustable alarm set-points are factory set 10°C above and below set-point. Alarm parameters are adjustable by pressing up or down arrow keys and following the prompt.



TOUCH SCREEN LEGEND

- 1. Present temperature display field:**
The current chamber temperature is displayed.
- 2. Set temperature value display field:**
The set value of chamber temperature is displayed.
Default setting: -80°C.
- 3. Message display field:**
Alarms, errors or messages are displayed when a fault occurs.
- 4. Filter display:**
Lights when the condenser filter has excessive dust accumulated on it and requires cleaning.
- 5. Alarm display:**
Normal condition: "Normal" is displayed.
Alarm-activated, buzzer-delayed: "Alarm" is displayed.
Alarm-activated, buzzer-sounding: "Warning" is displayed.
- 6. Outer door (opening / closing display)**

VIP SERIES FEATURES

What It Is	What It Does	Why It Is Important
Efficient Refrigeration	Microprocessor control over all cooling functions delivers cooling on demand.	Optimizes run time to minimize energy consumption.
Integrated Control Center	Combines all control, alarm, monitoring and data management functions into a single system.	High visibility LED display provides a convenient user interface to setpoints, alarm parameters, internal diagnostics, communications and security.
Structural Enhancement	Integrates inventory management, access and on site installation.	Cabinet design features include high-strength, lockable door latches and doors, latchable inner doors, adjustable shelves and locking casters to simplify operation and installation.
Compliant to International Standards	Assures quality standards, safety and performance criteria are met or exceeded.	Essential for compliance with CE and other third-party standards and recommended practices.
Ergonomic Design	One-handed outer and inner door latches and quiet-running compressors improve convenience, minimize sound.	Easy access to controls, displays and inventory racks, while low noise operation permits a wider choice of installation locations.

Ideal preservation environment for long-term storage

WATER COOLED OPTION

A water cooled condenser option is available for models MDF-DU502VH-PE and MDF-DU702VH-PE for facilities equipped with chilled recirculating water systems (fully water cooled or hybrid). This option utilizes the cascade refrigeration design to reuse energy produced by an ultra low freezer while delivering additional energy-savings and high performance cooling. Ideal for material storage in repositories, hospitals, clinics and medical research facilities, the water cooled system provides a range of benefits.

- Energy efficiency
- Cost saving
- Re-use of energy
- Faster recovery time
- Improved sample security

How watercooling works

- Phase 1** Heat generated from the freezer compartment is transferred to a water circuit using a plate heat exchanger.
- Phase 2** Transport the absorbed heat/energy from the freezer.
- Phase 3** Possibility to re-use heat/energy for other heat/energy demanding systems.

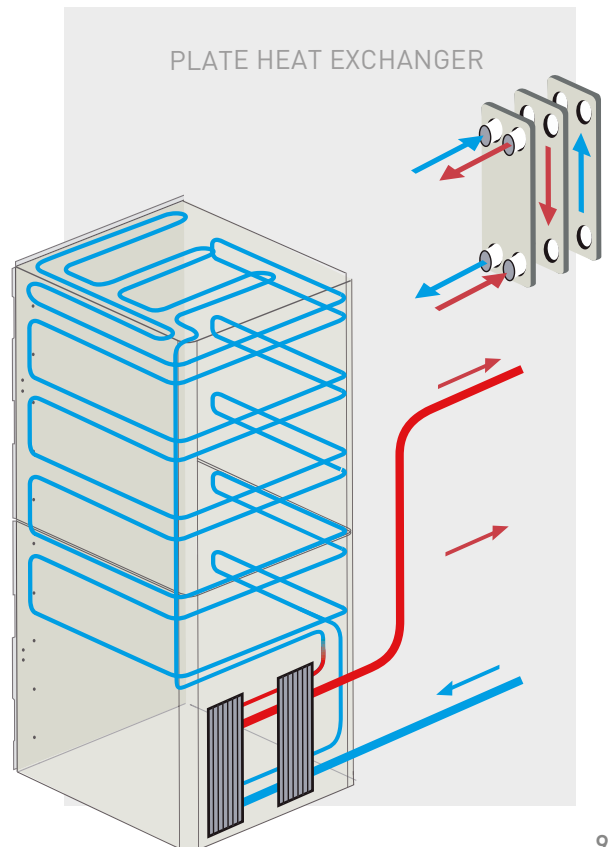

VIP ECO ULT Freezers

VIP ECO Ultra Low Temperature Freezers with natural refrigerants minimise energy consumption, reduce environmental impact and save money. Innovative technology and Class IIa Medical Device Certification provide secure storage of valuable research and clinical samples. The VIP vacuum insulation ensures an optimal footprint to storage capacity ratio.

The **VIP ECO** ULT Freezers use vacuum insulation panel (VIP) technology reducing wall thickness by around 50%, achieving 30% more storage capacity, and reducing the average cost per box stored. Leveraging the power of natural hydrocarbon refrigerants also allows the **VIP ECO** ULT Freezers to use smaller compressors, and reduce energy consumption. The natural hydrocarbon refrigerants combined with VIP insulation technology also help the environment by reducing the carbon footprint with up to 40% fewer emissions.



Model: MDF-DU702VH-PE

MDF-DU502VH and MDF-DU702VH Freezers are certified as a Class IIa Medical Device (93/42/EEC and 2007/47/EC) for medical purposes of storing cells, tissues, organs and embryos.

*Not applicable when fitted with water cooled condenser option.



REDUCED RUNNING COSTS

VIP ECO Ultra Low Temperature Freezers, with reduced power consumption, have the benefit of much lower running costs. They also dissipate less heat, reducing air conditioning requirements for further cost savings.

- 1) Model MDF-DU702VH-PE (728 litres) compared to MDF-U73V at set value -80°C, 23°C ambient, no load, 230V 50Hz, € 0.12/kWh. Actual energy use and savings will depend on operating conditions and price of electricity paid.
- 2) Model MDF-DU502VH-PE (526 litres) compared to MDF-U53V at set value -80°C, 23°C ambient, no load, 230V 50Hz, € 0.12/kWh. Actual energy use and savings will depend on operating conditions and price of electricity paid.

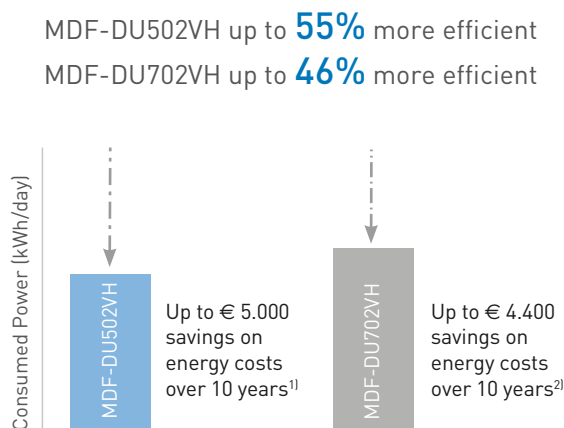

EXTREMELY LOW ENVIRONMENTAL IMPACT

Naturally occurring hydrocarbon (HC) refrigerants used within the **VIP ECO** ULT Freezers are non ozone depleting, have short atmospheric lifetimes and have extremely low global warming potentials (GWP's). This makes the freezers very environmentally friendly so they are an ideal solution for complying with objectives for reduced carbon footprints.

VIP -80°C Chest Freezer

Small installation space,
great storage capacity



PRODUCT FEATURES

- Alarm lamp and buzzer offer secure warning of power failure or abnormal temperature increase.
- High and low temperature warning provides an audible and visual alarm when the temperature deviates more than $\pm 5^{\circ}\text{C}$ to $\pm 20^{\circ}\text{C}$ (adjustable) from the set point.
- Alarm ring-back function ensures the buzzer will resume operation should alarm conditions continue after it is silenced.
- Control panel with digital display for easy operation.

SINGLE-COMPRESSOR SYSTEM

Use of a specially developed single compressor system achieves an approximately 40% reduction in power consumption and enables low-noise operation.

HIGH EFFICIENCY INSULATION

PHCbi's patented VIP PLUS technology has resulted in a revolutionary vacuum insulation cabinet construction that reduces wall thickness by approximately one half and achieves up to 30% more storage capacity than conventionally insulated freezers of the same footprint. This technology allows the MDF-C8V1 to require a small installation space with a great storage capacity.



Model: MDF-C8V1-PE

Space efficiency

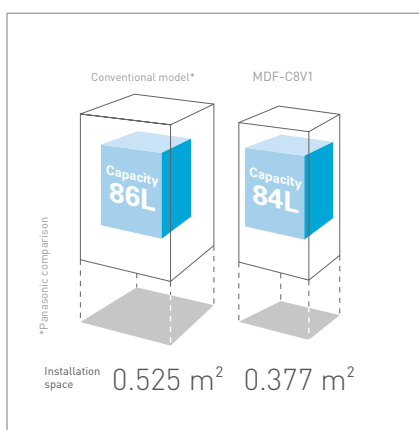

COOLING CIRCUIT ENABLES FILTERLESS STRUCTURE

A new cooling circuit makes the inconvenient customer maintenance procedure of filter cleaning unnecessary.

SPECIFICATIONS

VIP ECO Upright ULT Freezers			
Model Number		MDF-DU502VH-PE	MDF-DU702VH-PE
Dimensions			
External dimensions (WxDxH) ¹⁾	mm	790 x 882 x 1993	1030 x 882 x 1993
Internal dimensions (WxDxH)	mm	630 x 600 x 1400	870 x 600 x 1400
Volume	litres	528	729
Capacity	2" boxes	384	576
Net weight (approx)	kg	246	278
Performance			
Cooling performance ²⁾	°C	-86	
Temperature setting range	°C	-50 ~ -90	
Temperature control range ²⁾	°C	-50 ~ -86	
Control			
Controller		Microprocessor non-volatile memory	
Display		LCD Touch Screen	
Temperature sensor		Pt-1000	
Refrigeration			
Refrigeration system		Cascade	
High-stage compressor	W	750	
High-stage refrigerant		HC	
Low-stage compressor	W	750	
Low-stage refrigerant		HC	
Insulation material		PUF / VIP PLUS	
Insulation thickness	mm	80	
Construction			
Exterior material		Painted steel	
Interior material		Painted steel	
Outer door lock		Y	
Inner door/lid	qty	2 (insulated)	
Shelves	qty	3	
Max. load - per shelf	kg	50	
Max. load - total	kg	415	515
Vacuum release port		2 (1 automatic, 1 manual)	
Access port	qty	3	
- position		Back x 1 / bottom x 2	
- diameter	Ø mm	17	
Casters	qty	4 (2 levelling feet)	
Alarms			
Power failure		V-B-R	
High temperature		V-B-R	
Low temperature		V-B-R	
Filter		V	
Door open		V-B	
Electrical and Noise Level			
Power Supply		230V 50Hz single phase	
Noise Level ³⁾	dB(A)	52	
Options			
Liquid CO ₂ back-up		MDF-UB7-PW	
Liquid N ₂ back-up		-	
Temperature recorders			
- Circular type		MTR-G85C-PE	
- Chart paper		RP-G85-PW ⁶⁾	
- Ink pen		PG-R-PW	
- Continuous strip type		MTR-85H-PW	
- Chart paper		RP-85-PW ⁶⁾	
- Ink pen		DF-38FP-PW	
- Recorder housing		MDF-S3085-PW	
Drawers	qty	-	
Small inner door kit	set of 2	-	
	set of 5	MDF-5ID5-PW ⁴⁾	MDF-7ID5-PW ¹⁾
	set of 4	MDF-5ID4-PW	MDF-7ID4-PW

Appearance and specifications are subject to change without notice.

1) Exterior dimensions of main cabinet only, excluding handle and other external projections
 - See dimensions drawings on website for full details
 2) Air temperature measured at freezer centre, ambient temperature +30°C, no load
 3) Nominal value - Background noise 20dB

4) Requires sensor cover MTR-DU700SF
 5) Requires sensor cover MTR-C8-PW
 6) Installation of small inner door kit may affect usable storage capacity

VIP Upright ULT Freezers			VIP Chest ULT Freezer
MDF-U33V-PE	MDF-U55V-PE	MDF-DU901VHL-PE	MDF-C8V1-PE
670 x 867 x 1860	770 x 870 x 1990	1150 x 870 x 1993	550 x 685 x 945
490 x 600 x 1140	630 x 600 x 1380	1010 x 600 x 1400	405 x 490 x 425
333	519	845	84
216	352	672	42
255	290	328	67
	-86		-80
	-50 ~ -90		-55~-90
	-50 ~ -86		-60 ~ -80
Microprocessor non-volatile memory			Microprocessor non-volatile memory
LED	LED	LCD Touch Screen	LED
	Pt-1000		Pt-1000
	Cascade		Auto-cascade
450	450	2x1000	-
	HFC	HC	-
	750	-	400
	HFC	HC	HFC mixed
PUF / VIP PLUS	PUF / VIP PLUS	PUF / VIP PLUS	PUF / VIP PLUS
	70	80	70
	Painted steel		Painted steel
	Painted steel		Painted steel
	Y		Y
	2 (insulated)		1
	3		-
	50		-
	150		100
	Y		
3	3	2	2
Back/bottom x 2	Back/bottom x 2	Back/bottom	Back/bottom
	17		17
	4 (2 levelling feet)		4 (2 levelling feet)
	V-B-R		V-B-R
	V-B-R		V-B-R
	V-B-R		V-B-R
	V-B		Filterless design
	V-B		-
	230V 50Hz single phase		230V 50Hz single phase
49	47	52	47
	CVK-UB2-PW	MDF-UB7-PW	CVK-UB4-PW
	CVK-UBN2-PW	-	CVK-UBN2-PW
	MTR-G85C-PE		MTR-G85C-PE ⁵⁾
	RP-G85-PW		RP-G85-PW
	PG-R-PW		PG-R-PW
	MTR-85H-PW		MTR-85H-PW
	RP-85-PW		RP-85-PW
	DF-38FP-PW		DF-38FP-PW
	MDF-S3085-PW		MDF-S3085-PW
MDF-30R-PW (Max 2)	MDF-50R-PW (Max 1)	-	-
-	MDF-5ID-PW (Max 2) ⁶⁾	MDF-9ID-PW (max 2) ⁶⁾	-
	-	-	-
	-	-	-

SPECIFICATIONS

Dimensions & Performance Data

MDF-DU502VH-PE - 526 LITRES

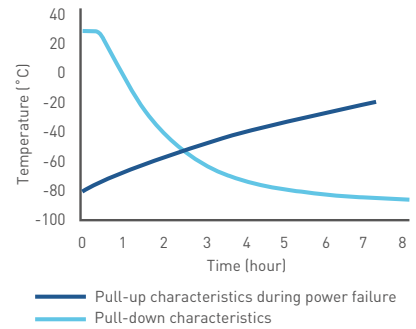
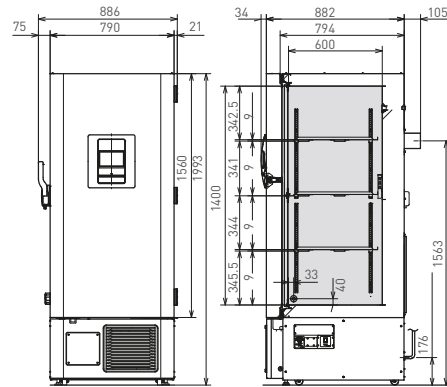

MDF-DU702VH-PE - 729 LITRES

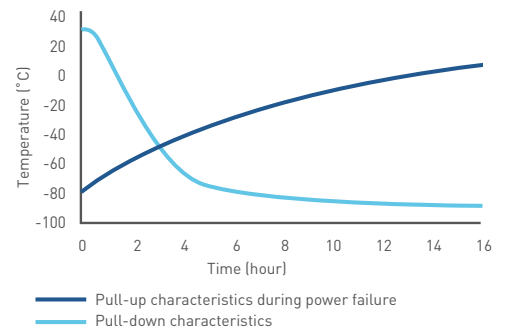
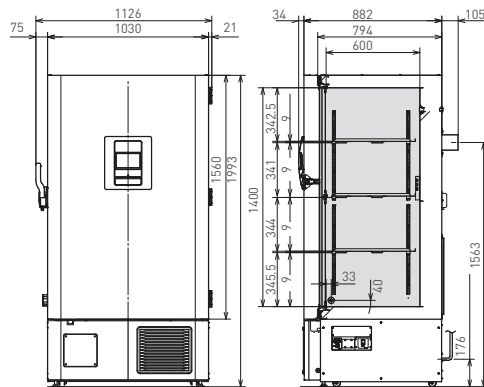

MDF-U33V-PE - 333 LITRES

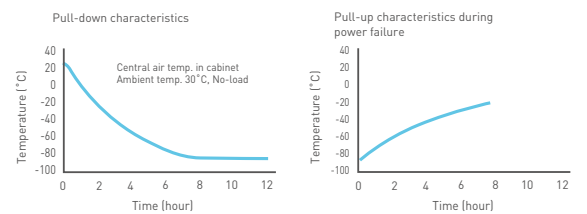
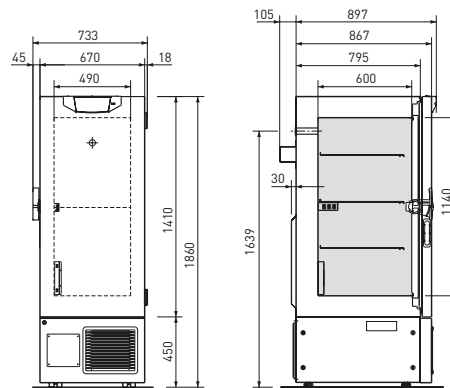

Dimensions & Performance Data

MDF-U55V-PE - 519 LITRES

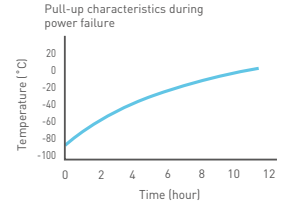
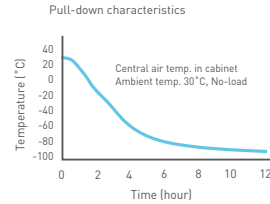
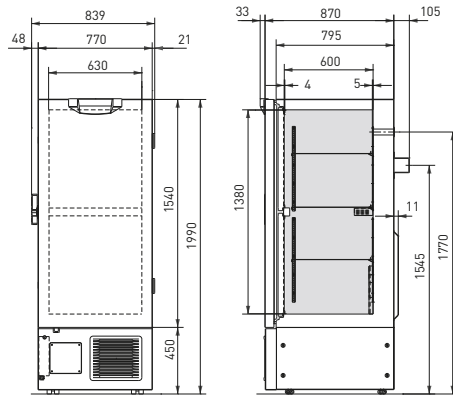

MDF-DU901VHL-PE - 845 LITRES

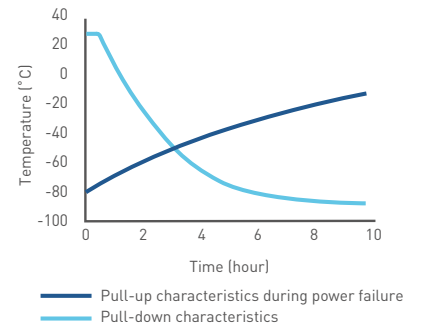
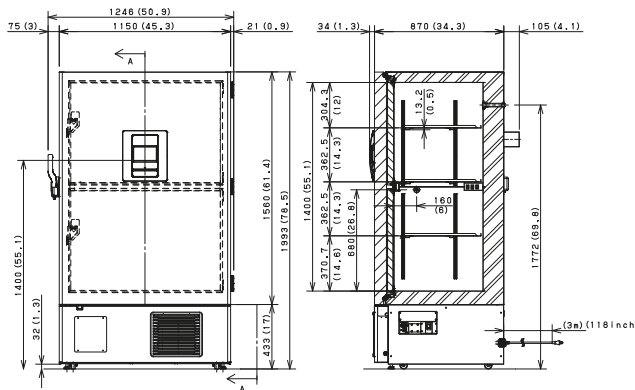

MDF-C8V1-PE - 84 LITRES

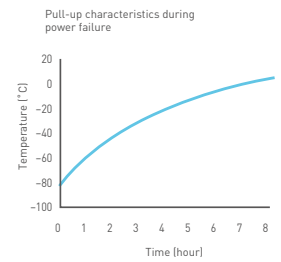
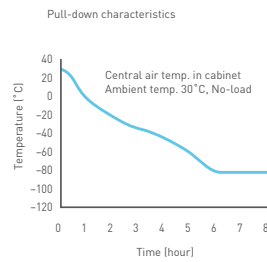
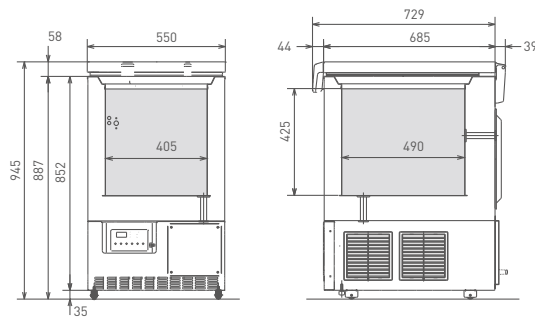

VIP insulation maximizes storage capacity

RACK CONFIGURATIONS

Models: MDF-DU502VH-PE | MDF-DU702VH-PE | MDF-U33V-PE | MDF-U55V-PE |
MDF-DU901VHL-PE | MDF-C8V1-PE

Vertical rack type	Box type	Rack/quantity Aluminium	Total boxes		Rack/quantity Stainless steel	Total boxes
MDF-DU502VH-PE						
with trays	(P) A1	4 x HCS-296	384			
with trays	(P) A1	16 x HCS-6564	384	2" Cardboard boxes	16 x SDR-624-N	384
side opening	(P) A1	16 x NIR-224U	384	2" Cardboard boxes	16 x SUR-624-N	384
with trays	(P) A2	16 x HCS-4804	256	3" Cardboard boxes	16 x SDR-434-N	256
side opening	(P) A2	16 x NIR-316U	256	3" Cardboard boxes	16 x SUR-434-N	256
MDF-DU702VH-PE						
with trays	(P) A1	6 x HCS-296	576			
with trays	(P) A1	24 x HCS-6564	576	2" Cardboard boxes	24 x SDR-624-N	576
side opening	(P) A1	24 x NIR-224U	576	2" Cardboard boxes	24 x SUR-624-N	576
with trays	(P) A2	24 x HCS-4804	384	3" Cardboard boxes	24 x SDR-434-N	384
side opening	(P) A2	24 x NIR-316U	384	3" Cardboard boxes	24 x SUR-434-N	384
MDF-U33V-PE						
with trays	(P) A1	6 x HCS-32-4584/143 + 6 x HCS-32-5584/143	216	2" Cardboard boxes	6 x SDR-424-N + 6 x SDR-524-N	216
side opening	(P) A1	6 x NIR-216U + 6 x NIR-220U	216	2" Cardboard boxes	6 x SUR-424-N + 6 x SUR-524-N	216
with trays	(P) A2	12 x HCS-32-3804/143	144	3" Cardboard boxes	12 x SDR-334-N	144
side opening	(P) A2	12 x NIR-312U	144	3" Cardboard boxes	12 x SUR-334-N	144
MDF-U55V-PE						
with trays	(P) A1	4 x HCS-519	352			
with trays	(P) A1	8 x HCS-5584 + 8 x HCS-6564	352	2" Cardboard boxes	8 x SDR-524-N + 8 x SDR-624-N	352
side opening	(P) A1	8 x NIR-220U + 8 x NIR-224U	352	2" Cardboard boxes	8 x SUR-524-N + 8 x SUR-624-N	352
with trays	(P) A2	8 x HCS-4804 + 8 x HCS-3804	224	3" Cardboard boxes	8 x SDR-334-N + 8 x SDR-434-N	224
side opening	(P) A2	8 x NIR-316U + 8 x NIR-312U	224	3" Cardboard boxes	8 x SUR-334-N + 8 x SUR-434-N	224
MDF-DU-901VHL-PE						
with trays	(P) A1	14 x HCS-5584 + 14 x HCS-6564	616	2" Cardboard boxes	28 x SDR-624-N	672
side opening	(P) A1	14 x NIR-220U + 14 x NIR-224U	616	2" Cardboard boxes	28 x SUR-624-N	672
with trays	(P) A2	14 x HCS-4804 + 14 x HCS-3804	392	3" Cardboard boxes	14 x SDR-334-N + 14 x SDR-434-N	392
side opening	(P) A2	14 x NIR-316U + 14 x NIR-312U	392	3" Cardboard boxes	14 x SUR-334-N + 14 x SUR-434-N	392
MDF-C8V1-PE						
side openings	(P) A1	6 x NIR-207C	42	2" Cardboard boxes	6 x SCR-072-N	42
side openings	(P) A2	6 x NIR-305C	30	3" Cardboard boxes	6 x SCR-053-N	301

	Box Type	Aluminium Rack	Box Type	Stainless steel Rack
Dimensions of cardboard 2" boxes in mm (WxDxH):	A1	133 x 133 x 48	B2C	134 x 134 x 51
Dimensions of polycarbonate 2" boxes in mm (WxDxH):	PA1	133 x 133 x 45		
Dimensions of cardboard 3" boxes in mm (WxDxH):	A2	133 x 133 x 71	B3C	134 x 134 x 77
Dimensions of polycarbonate 3" boxes in mm (WxDxH):	PA2	133 x 133 x 70		

Please check specific inventory requirements with your local PBCbi representative to ensure suitability of racks and boxes.. Other systems, including bespoke racking, are also available.

Appearance and specifications are subject to change without notice.