



Sonicator

ULTRASONIC PROCESSOR

Part No. Q2000/Q2000FCE

OPERATION MANUAL



HIGH INTENSITY ULTRASONIC PROCESSOR

2000 Watt Model

TABLE OF CONTENTS

Warranty	3
Important Safeguards	4
Specifications	5-6
SECTION I – INSTALLATION	
Inspection	7
Electrical Requirements	7
Installing the Ultrasonic Processor	7
Description of Components	8
Q2000 Assembly	10-11
Converter Cooling.....	12
Q2000FCE Assembly	13-19
SECTION II – OPERATION	
Principles of Ultrasonic Disruption	20-21
Set up and Getting Started.....	22-23
Functions of Controls, Indications, and Connectors	24-25
Preparation for Use	26
Using the Ultrasonic Processor	27-34
SECTION III – SERVICE INFORMATION	
Service and Maintenance	35-37
Qsonica Safety Certification Form.....	38

The Ultrasonic Processor supplied with this instruction manual is constructed of the finest material and the workmanship meets the highest standards. It has been thoroughly tested and inspected before leaving the factory and when used in accordance with the procedures outlined in this manual, will provide you with many years of safe and dependable service.

Rev. 1/20

WARRANTY

Your Ultrasonic Processor is warranted for a period of two years from the date of shipment against defects in material and workmanship under normal use as described in this instruction manual. During the warranty period, the manufacturer will, at its option, as the exclusive remedy, either repair or replace without charge for material and labor, the part(s) which prove to be defective, provided the unit is returned to us properly packed with all transportation charges prepaid.

Ultrasonic probes are guaranteed against defects for a period of one year from date of shipment. A defective probe will be replaced once without charge, if failure occurs within the warranty period. Wear resulting from cavitation erosion is a normal consequence of ultrasonic processing, and is not covered by this warranty.

This warranty is in lieu of any other warranties, either express, implied, or statutory. The manufacturer neither assumes nor authorizes any person to assume for it any other obligations or liability in connection with the sale of its products. The manufacturer hereby disclaims any warranty of either merchantability or fitness for a particular purpose. No person or company is authorized to change, modify, or amend the terms of this warranty in any manner whatsoever. Under no circumstances shall the manufacturer be liable to the purchaser or any other person for any incidental or consequential damages or loss of goodwill, production, or profit resulting from any malfunction or failure of its product.

This warranty does not apply to equipment that has been subject to unauthorized repair, misuse, abuse, negligence or accident. Equipment which, shows evidence of having been used in violation of operating instructions, or which has had the serial number altered or removed, will be ineligible for service under this warranty.

All probes are manufactured to exacting specifications and are tuned to vibrate at a specific frequency. Using an out-of-tune probe will cause damage to the equipment and may result in warranty nullification. The manufacturer assumes no responsibility for probes fabricated by another party or for consequential damages resulting from their usage.

The aforementioned provisions do not extend the original warranty period of any product that has either been repaired or replaced by the manufacturer.

IMPORTANT SAFEGUARDS

READ BEFORE INSTALLING OR USING THE EQUIPMENT

Your Ultrasonic Processor has been designed with safety in mind. However, no design can completely protect against improper usage, which may result in bodily injury and/or property damage. For your protection and equipment safeguard, observe the following warnings at all times, read the operating instructions carefully before operating the equipment, and retain this instruction manual for future reference. If the Ultrasonic Processor is used in a manner contrary to that specified in this instruction manual, the protection features designed into the unit may be impaired. Observe the following

WARNINGS:

- High voltage is present in the generator (power supply), converter and high frequency cable. There are no user-serviceable parts inside any of these devices. Do NOT attempt to remove the generator cover or converter case.
- Do NOT touch any open cable connections on the unit while the power is turned ON.
- Do NOT operate generator with converter disconnected from high voltage cable. High voltage is present in the cable and may pose a shock hazard.
- Do NOT attempt to disconnect the converter high voltage cable while the unit is running.
- The generator must be properly grounded with a 3-prong plug. Test electrical outlet for proper grounding before plugging in unit.
- Install the ultrasonic processor in an area free from excessive dust, dirt, explosive or corrosive fumes and protected from extremes in temperature and humidity. Do not place the Generator within a Fume Hood.
- Hearing protection is highly recommended. It is recommended that a sound abating enclosure or ear protection be used when operating the Ultrasonic Processor
- NEVER immerse the converter in liquids of any kind, or let condensed moisture or liquid drip into the converter.
- NEVER grasp an activated horn or probe. It can cause severe burns and tissue damage.
- NEVER allow a probe to vibrate in air.
- NEVER hold or clamp the converter by the front driver or by the horn itself. This can cause permanent damage to the system. Support the converter by only clamping around the converter housing (upper portion).
 - Air-cool the converter with 10psi, clean dry compressed air.
- Do NOT allow the tip of a vibrating horn or probe to touch the counter top or any other hard surface. It could damage the probe, overload the generator, or damage the surface.
- Avoid touching the bottom or sides of a glass or plastic container with an activated probe. It could crack or shatter the glass or melt the plastic.
- Turn OFF the power switch, unplug the generator and disconnect the power cord from the back of the generator before attempting to replace the fuses.
- Inspect high frequency cable for cracks in the protective outer jacket.
- Do not operate unit with a damaged cable. Doing so may cause serious injury.
- In case of AC power loss, wait 3 minutes minimum before reapplying power.
- Do not turn off AC mains power while running a horn. Stop sonication via touch screen prior to stopping power.

Symbols



Caution, Risk of electric shock, Hazardous voltage



Caution, Risk of danger. Refer to User Manual.

SPECIFICATIONS	
POWER SUPPLY	MODEL NUMBER: Q-2000XXX-220, XXX=ACCESSORY OPTIONS
	POWER RATING 2000 WATTS. FREQUENCY: 20 KHz
	DIMENSIONS: 7" X 15" X 18 ¼" (H x W x D) 178 mm x 380 mm x 463.5 mm
	WEIGHT: 21 lbs. (9.5 kg)
CONVERTER	
	PART NUMBER: CL-294
	DIAMETER: 3" (76.2 mm)
	LENGTH: 6 ¼" (158.7mm)
	WEIGHT: 2 lbs. (900 grams)
STANDARD PROBE	
	PART NUMBER: 4777
	DIAMETER: 1.5" (37 mm)
	LENGTH: 9.6" (244 mm) REFERENCE ONLY, ACTUAL TUNED LENGTH WILL VARY.
	WEIGHT: 2.0 lbs. (900 grams) REFERENCE ONLY, ACTUAL WEIGHT WILL VARY WITH TUNED LENGTH.
	TITANIUM ALLOY
STANDARD BOOSTER	
	PART NUMBER: 4121TI
	LENGTH: 5"
CONVERTER CABLE	
	CABLE LENGTH 10' (3 m)
ELECTRICAL REQUIREMENTS	
	230 VAC ± 10%, 50/60 Hz, SINGLE PHASE, 20 AMPS

POLLUTION DEGREE	2
INSTALLATION CATEGORY	II
ENVIRONMENT	INDOOR USE ONLY
HUMIDITY	MAXIMUM RELATIVE HUMIDITY 80 % FOR TEMPERATURES UP TO 31°C DECREASING LINEARLY TO 50% RELATIVE HUMIDITY AT 40°C
OPERATING LIMITS	TEMPERATURE: 41°F – 104°F (5°C - 40°C) ALTITUDE: 6,651 FEET (2000 METERS)
SHIPPING/STORAGE LIMITS	TEMPERATURE: -4°F – 120°F (-20°C - 49°C) RELATIVE HUMIDITY: 10 – 95 % (NON CODENSING) ALTITUDE: 40,000 FEET (12,192 METERS)
RESTRICTION OF HAZORDOUS SUBSTANCE (RoHS)	RoHS

*Only use IEC approved Fast acting fuses, Cooper Bussman series S500.

The Power Cord supplied with the ultrasonic processor must be used. If the 230V plug is not configured to match the wall receptacle, a properly grounded universal AC socket adapter must be added.

Important: Universal adapters do not convert voltage or frequency. The manufacturer is not responsible for damage caused by the use of an improper power cord or adapter. Transformers are not recommended.



WEEE Statement

This product contains electrical or electronic materials. The presence of these materials may, if not disposed of properly, have potential adverse effects on the environment and human health. Presence of this label on the product means it should not be disposed of as unsorted waste and must be collected separately. As a consumer, you are responsible for ensuring that this product is disposed of properly. To find out how to properly dispose of this product contact Customer Service.

SECTION 1 – INSTALLATION

INSPECTION

Prior to installing the Ultrasonic Processor, perform a visual inspection to detect any evidence of damage, which might have occurred during shipment. Before disposing of any packaging material, check it carefully for small items.

The equipment was thoroughly inspected and carefully packed before leaving our factory. The carrier, upon acceptance of the shipment, assumed responsibility for its safe delivery. Claims for loss or damage sustained in transit must be submitted to the carrier.

If damage has occurred, contact your carrier within 48 hours of the delivery date. **DO NOT OPERATE DAMAGED EQUIPMENT.** Retain all packing materials for future shipment.

ELECTRICAL REQUIREMENTS

The Ultrasonic Processor requires a fused, single phase 3-terminal grounding type electrical outlet capable of supplying **230 +/- 10% VAC, 50/60 Hz, 20 amps.**



WARNING

For your personal safety, do not, under any circumstances, defeat the grounding feature of the power cord by removing the grounding prong.



INSTALLING THE ULTRASONIC PROCESSOR

The ultrasonic processor should be installed in an area that is free from excessive dust, dirt, explosive and corrosive fumes, and extremes of temperature and humidity. If processing flammable liquids, use an approved fume hood and do not place the power supply in the fume hood.

Unit shall be placed on a flat clean level surface. The mounting feet shall not be removed from the bottom of the unit. The unit vents through the holes in the chassis located on the underside of the unit. Keep this area clear of debris and dust.

When positioning the unit, be sure to leave adequate space behind the unit so that all connections can be easily disconnected.

Verify the fan on the rear of the unit is rotating and operational.

DESCRIPTION OF COMPONENTS

The model Q2000 includes a 1.5" Diameter High Intensity Probe (Part #4777)

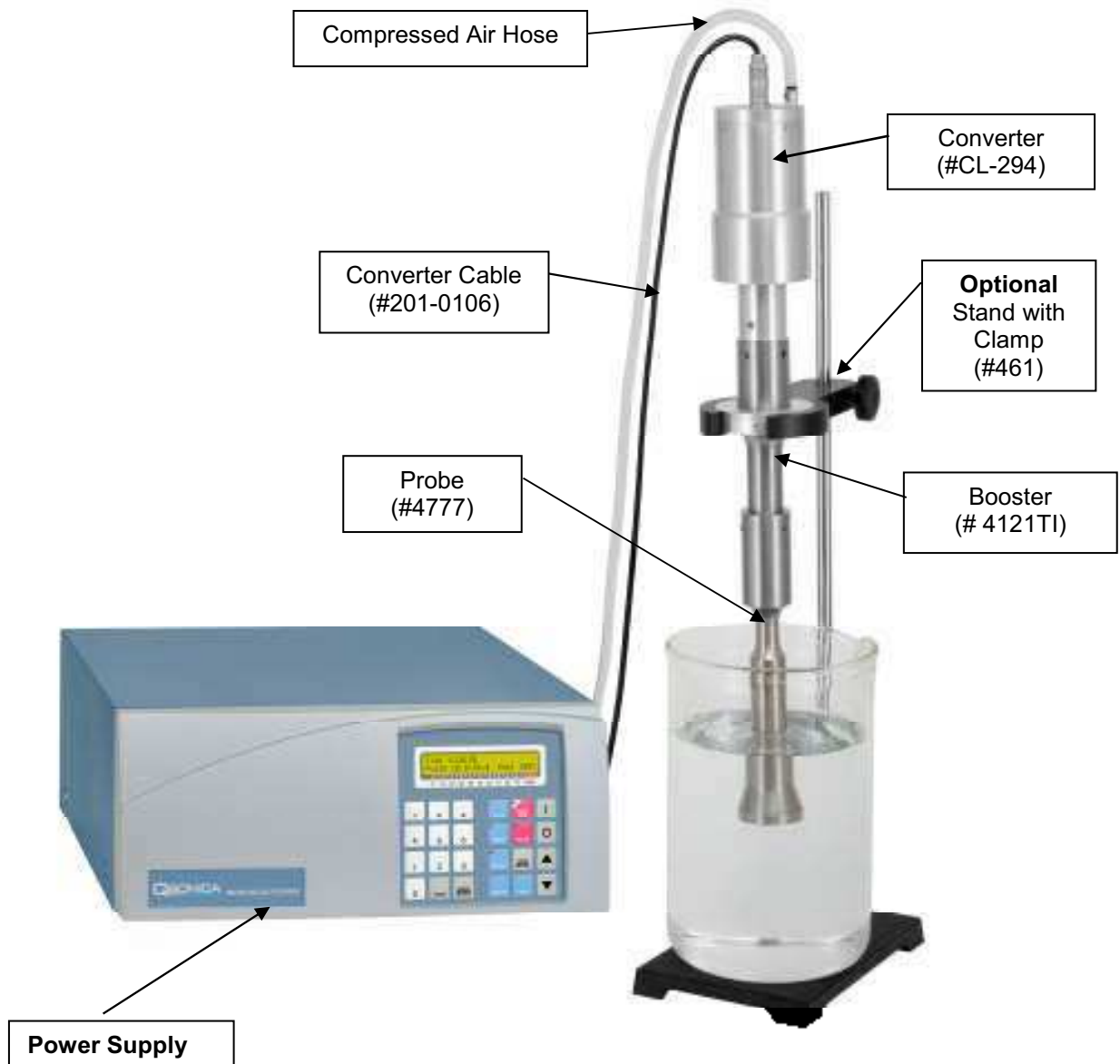

Note: the compressed air hose for cooling the converter is not included.

Q2000 REAR PANEL

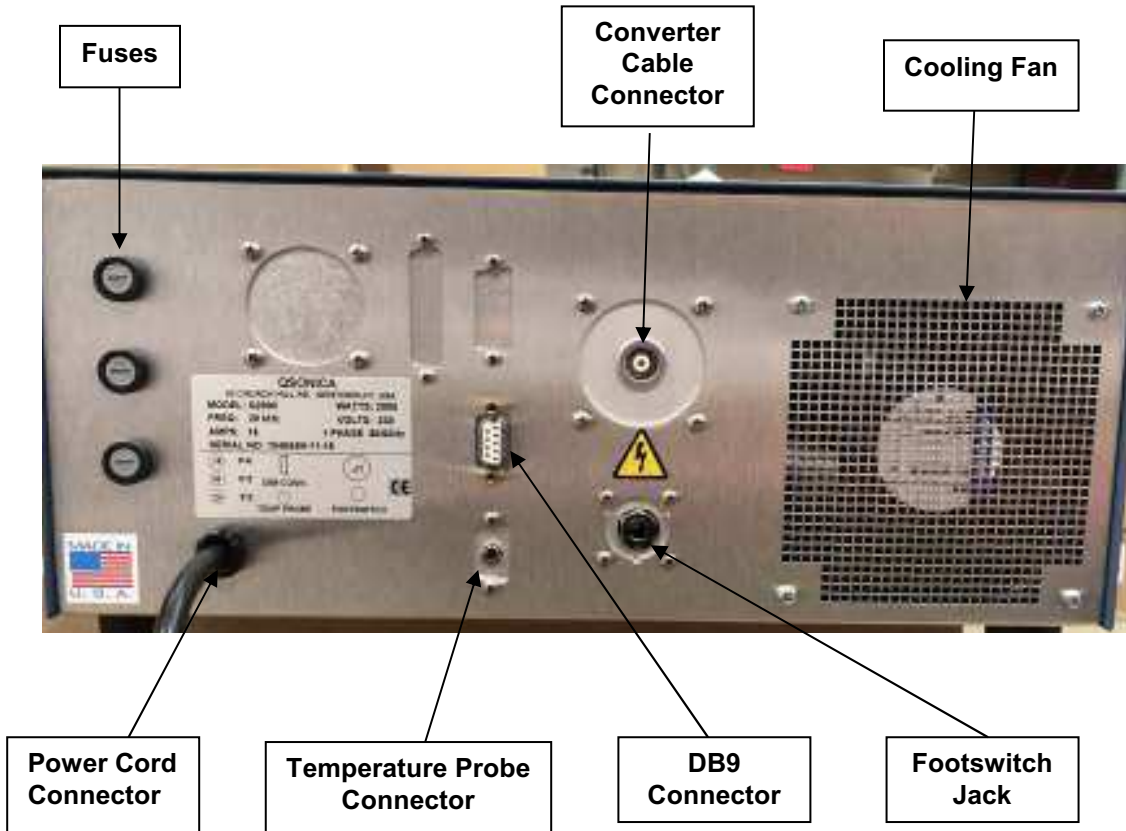

Q2000 ASSEMBLY

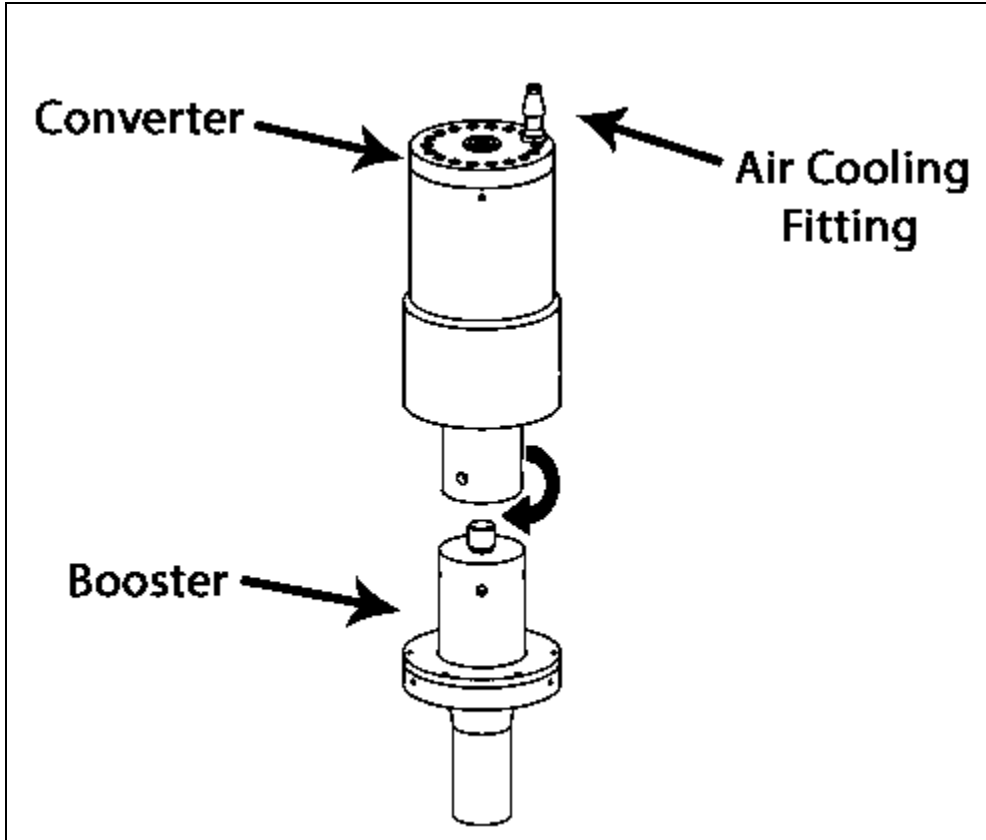

1. Screw the converter to booster by hand.

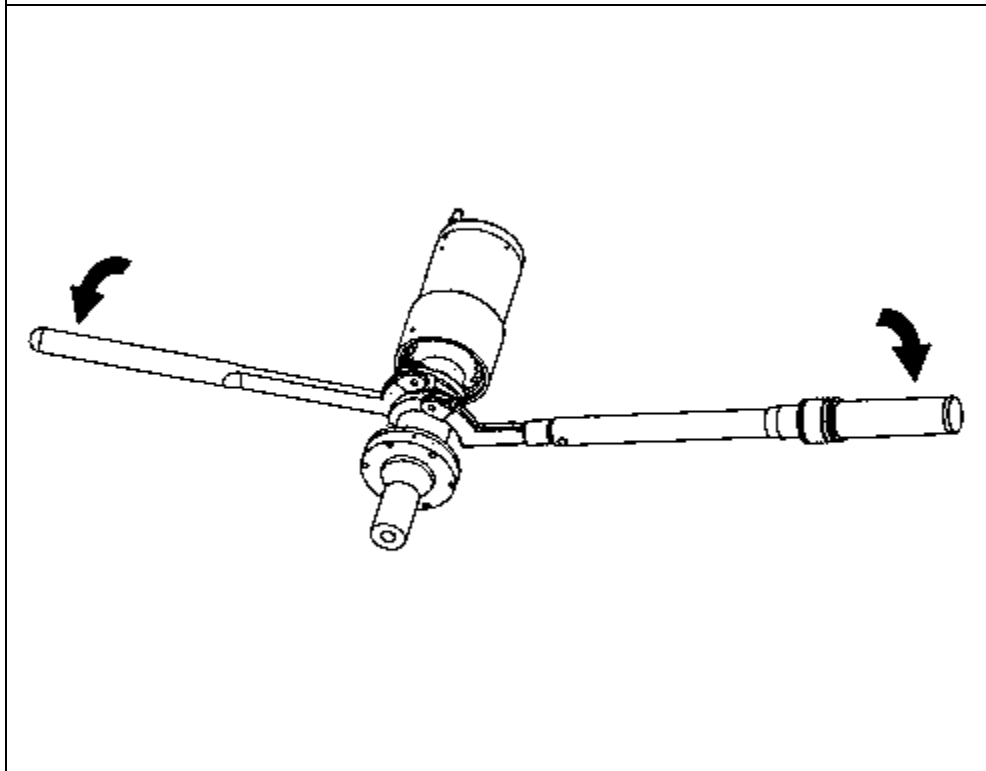

2. Set the Torque wrench to 64.5 ft.lb. Use the spanner wrench and Torque wrench to tightly attach the converter to the booster.

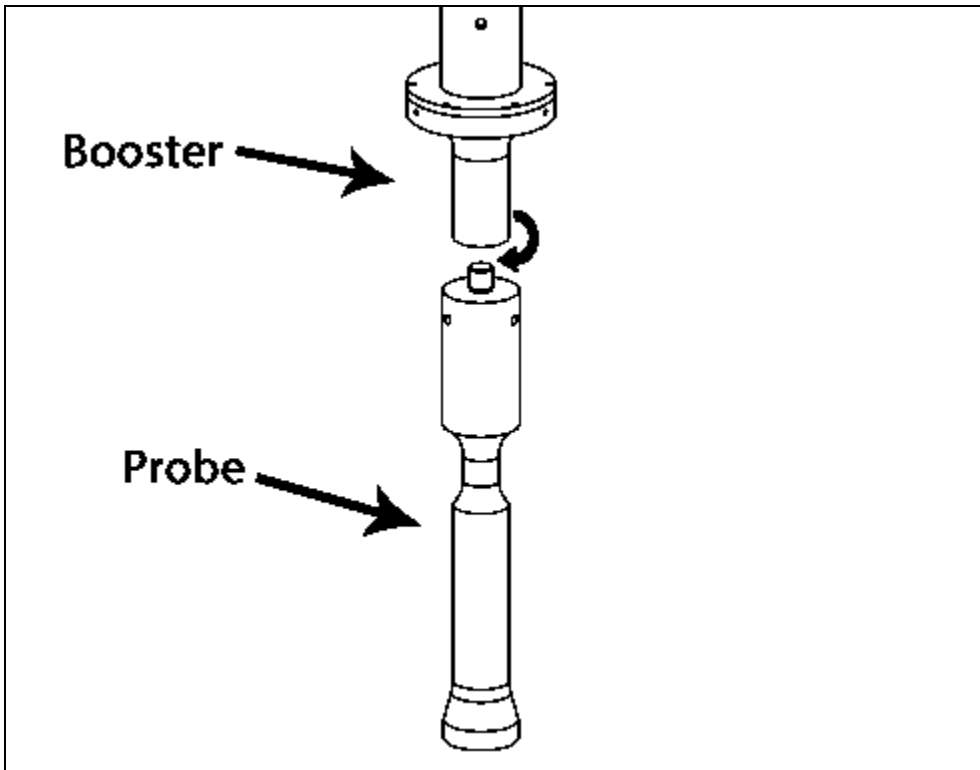

3. Screw the booster to the horn by hand.

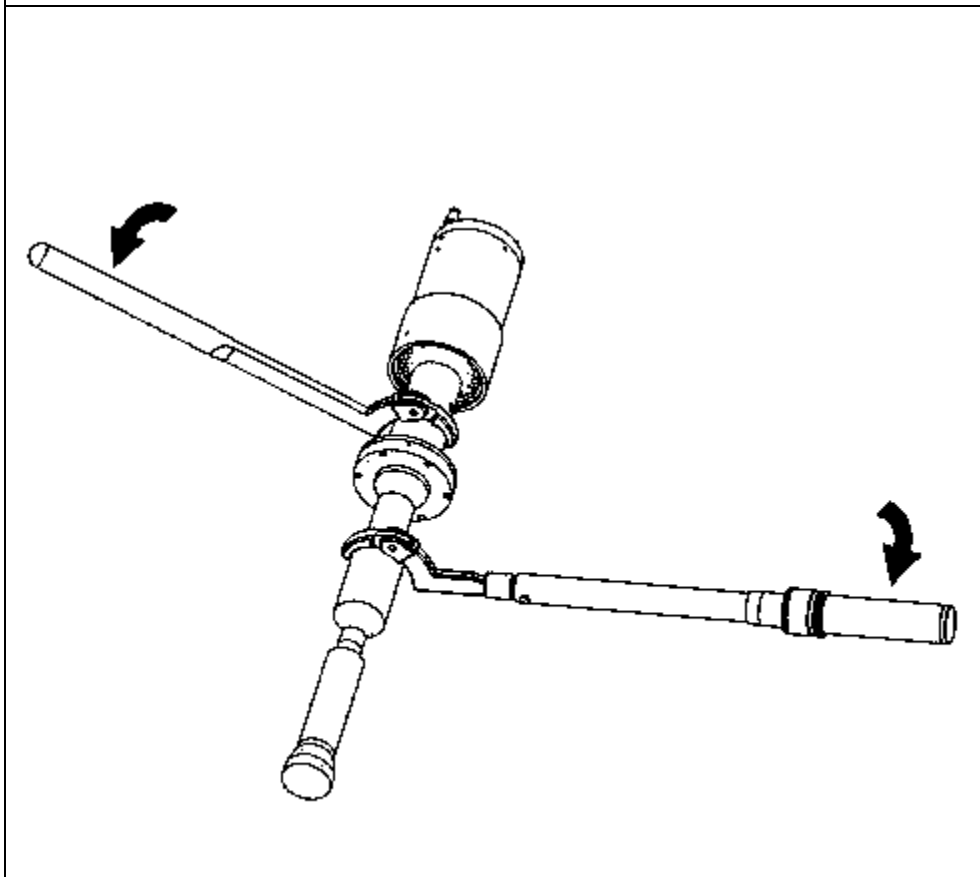

Converter Cooling for Q2000 systems

Introduction:

The nature of sonication causes the probe, converter and sample temperature to increase during operation. Processing samples requires significant amounts of energy and some of this energy manifests as heat in the converter and probe. The converter contains sensitive internal crystals which can crack due to overheating, which would require the converter to be replaced. Converter damage due to overheating is not covered under warranty. Air cooling using compressed air is required to always keep the converter within safe operating temperatures. The elements of the system will still heat up when air cooling is employed, but the converter will operate at an acceptable temperature for continuous use. It is important to note that your sample liquid may also require cooling, using an ice bath, heat exchanger or a chiller. Cooling both the sample and the converter will ensure safe operation.

Instructions:

Connect your compressed air source to the hose barb fitting on the top of the converter with 1/4" ID tubing.



The compressed air source must meet the following specification:

- 3-4 cubic feet per minute (CFM)
- 10 psig \pm 1
- 70°F
- Dry
- Oil free
- Filtered with a 5 micron filter

Any deviation from the above compressed air specifications may void the warranty. Contact us for assistance.

Q2000FCE ASSEMBLY (Optional Floccell Accessory)



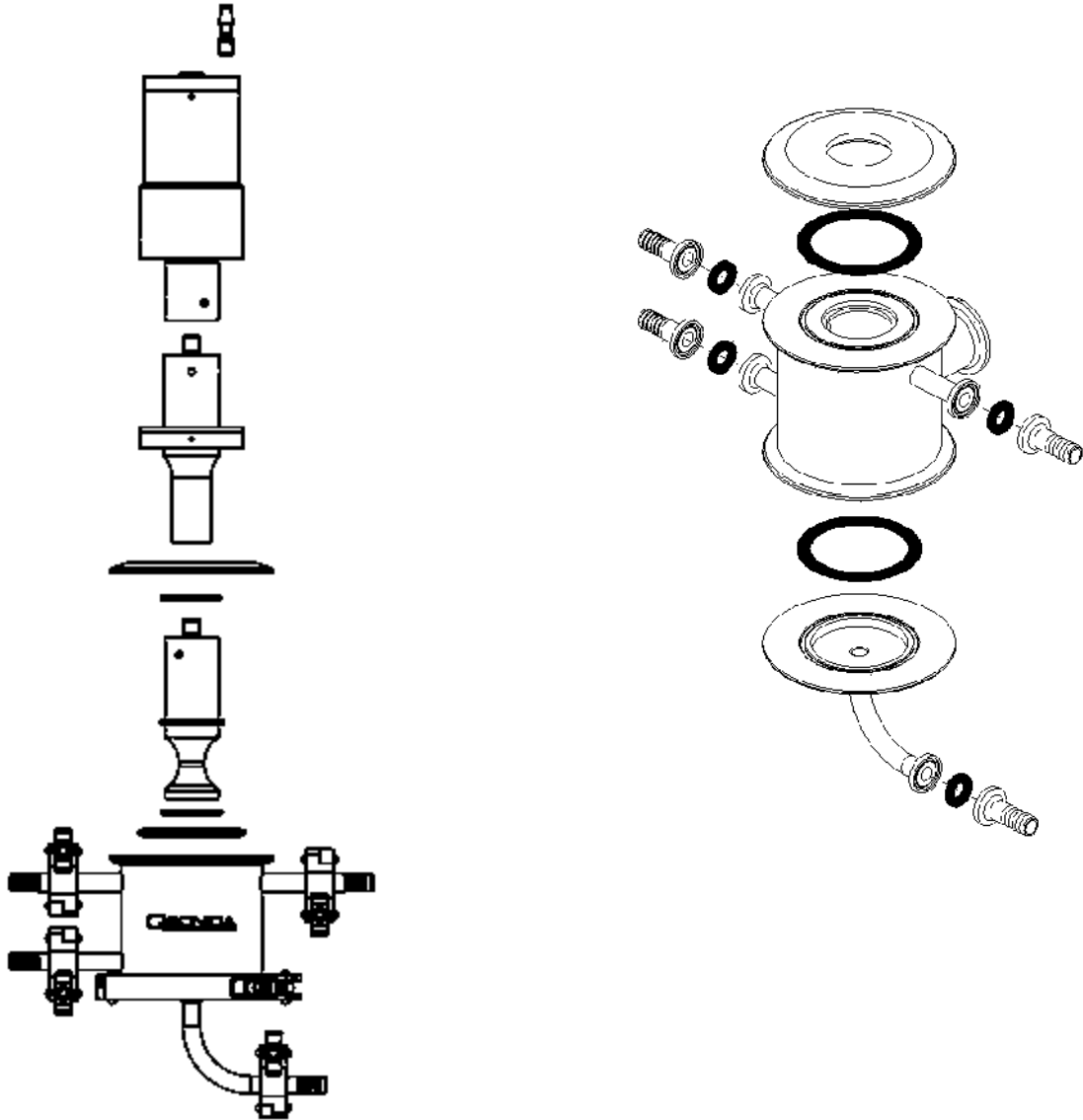

The Floccell process and water jacket connections are 1/2" sanitary fittings. For user convenience, mating sanitary fittings with hose barb adapters are also provided. The hose barbs accommodate 3/8" ID tubing.

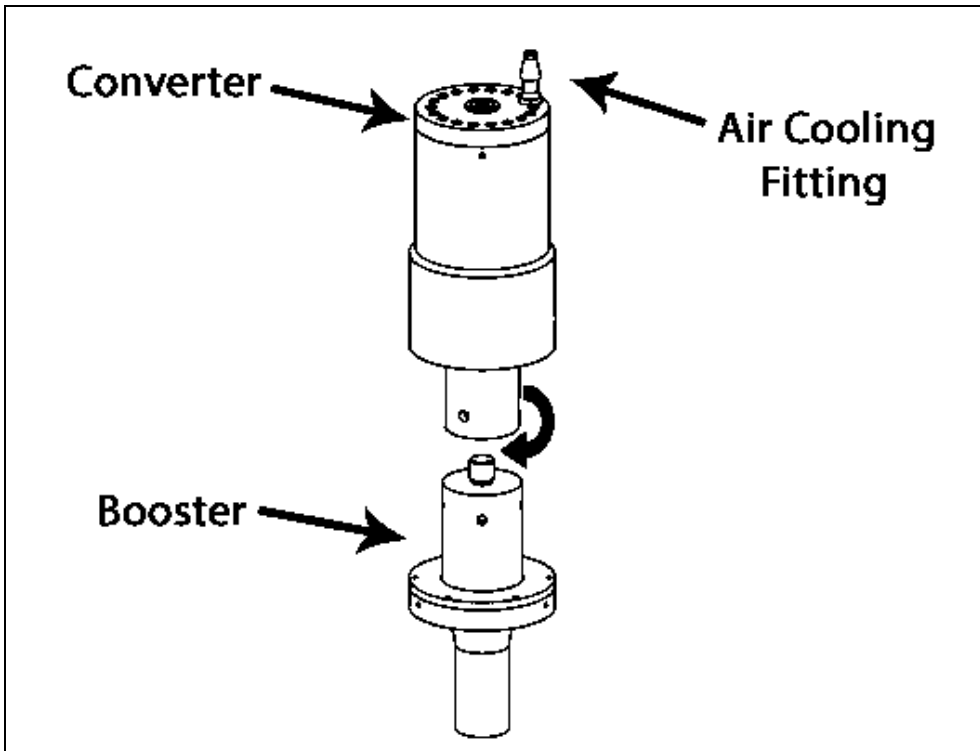

1. Screw the converter to booster by hand.

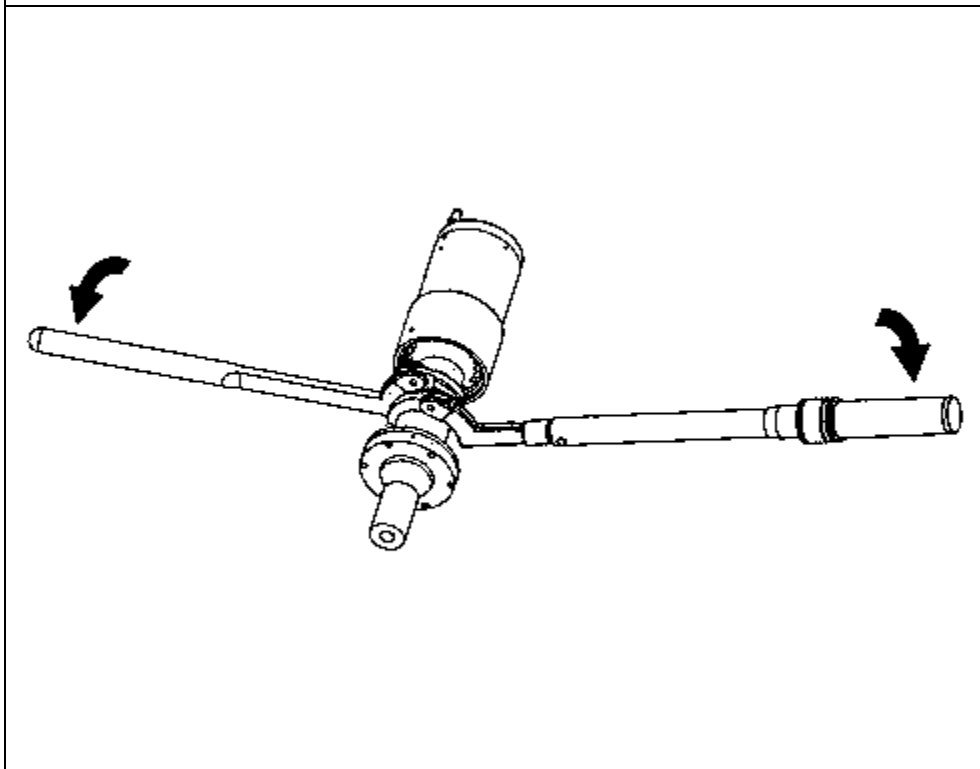

2. Set the Torque wrench to 64.5 ft.lb. Use the spanner wrench and Torque wrench to tightly attach the converter to the booster.

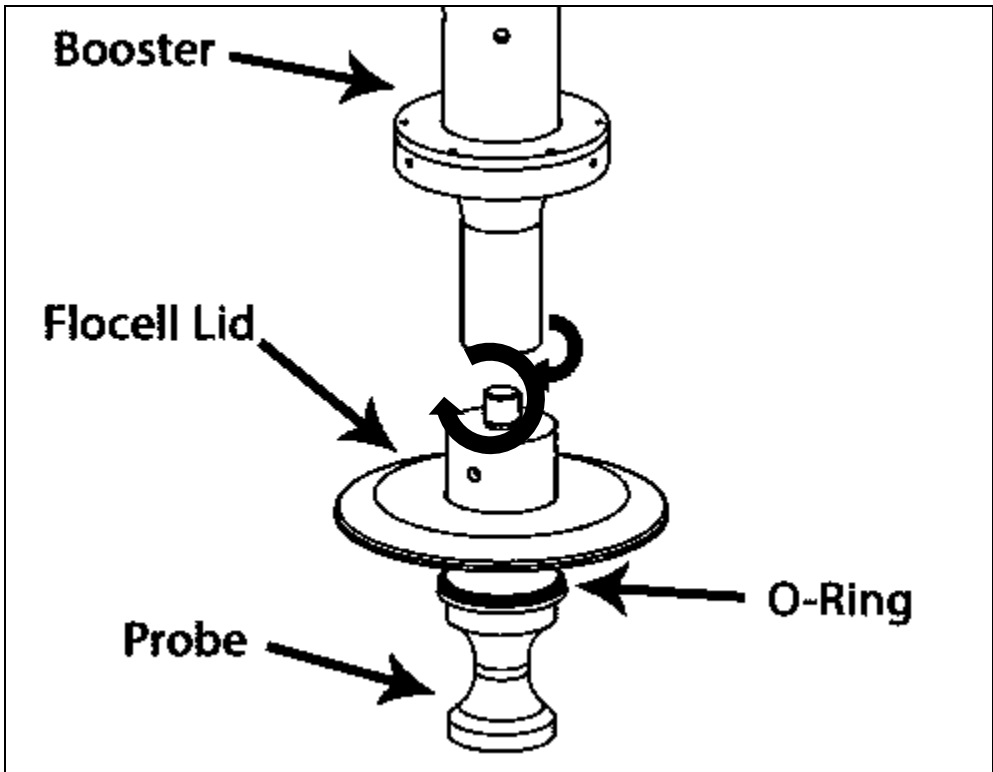

3. Slide o-ring onto the probe flange as shown.

4. Place floccell lid above the o-ring.

5. Screw the booster to probe by hand.

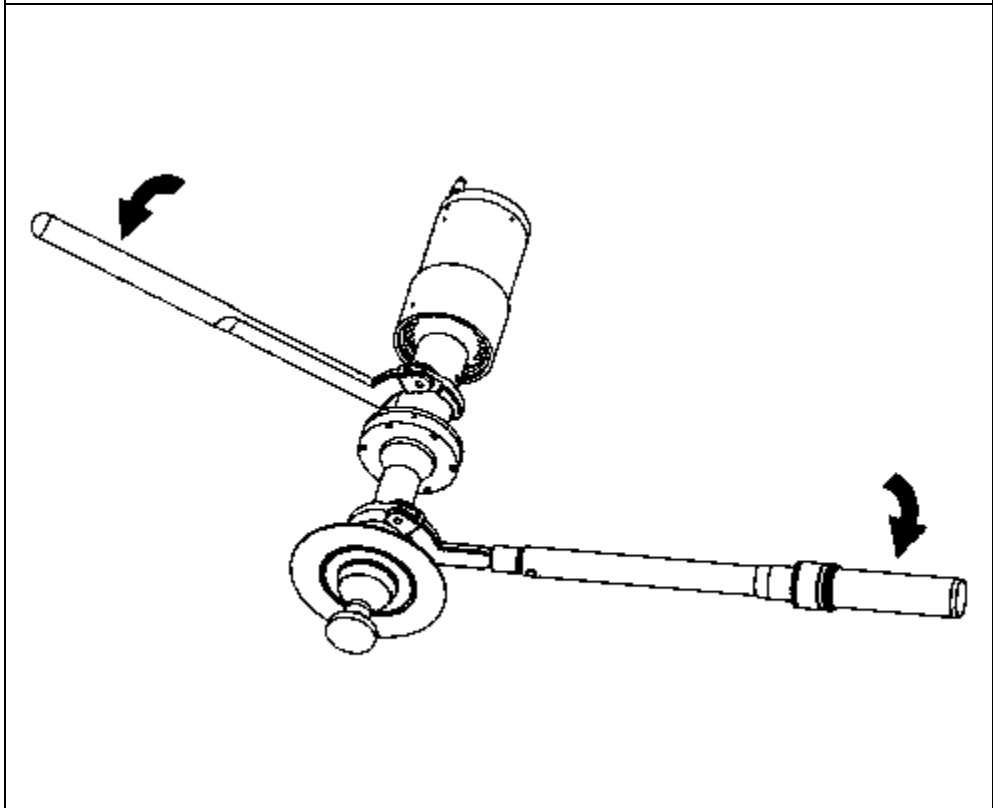

6. Set the Torque wrench to 64.5 ft.lb. With the probe and lid hanging over the edge of the benchtop - use the spanner wrench and Torque wrench to **tightly** attach the converter to booster.

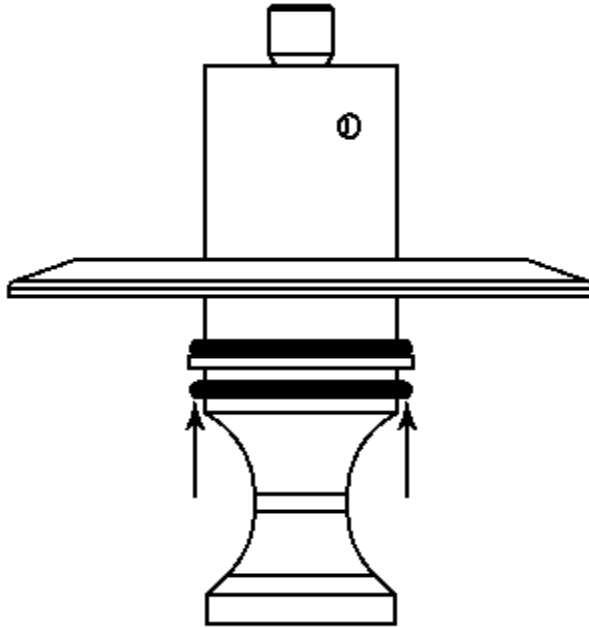

7. Slide o-ring to the bottom of probe flange as shown.

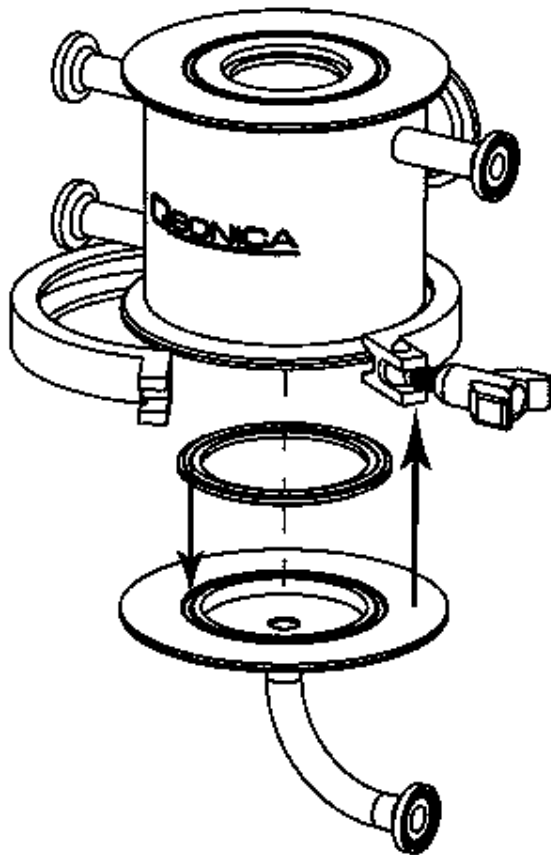

8. Align gasket in groove on the lower inlet chamber.

9. Attach to floccell body and lock tri-clamp.

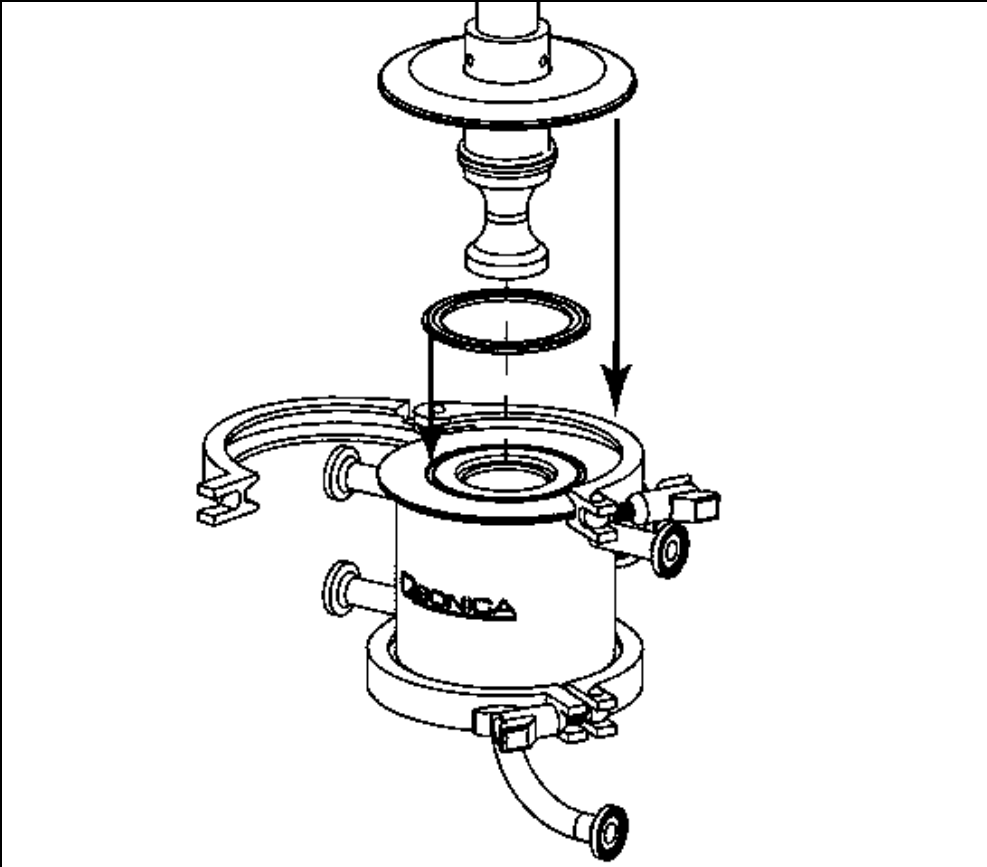

10. Align gasket in groove on top of floccell.

11. Insert probe and lid on top of floccell.

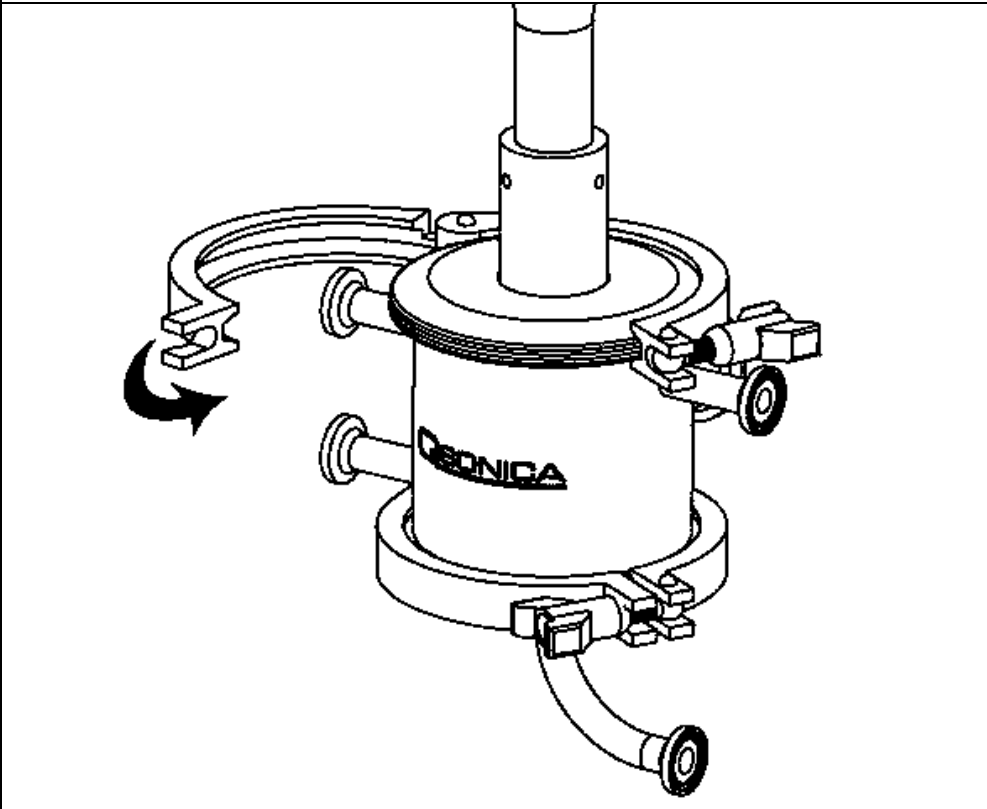

13. Attach to floccell body and lock tri-clamp.

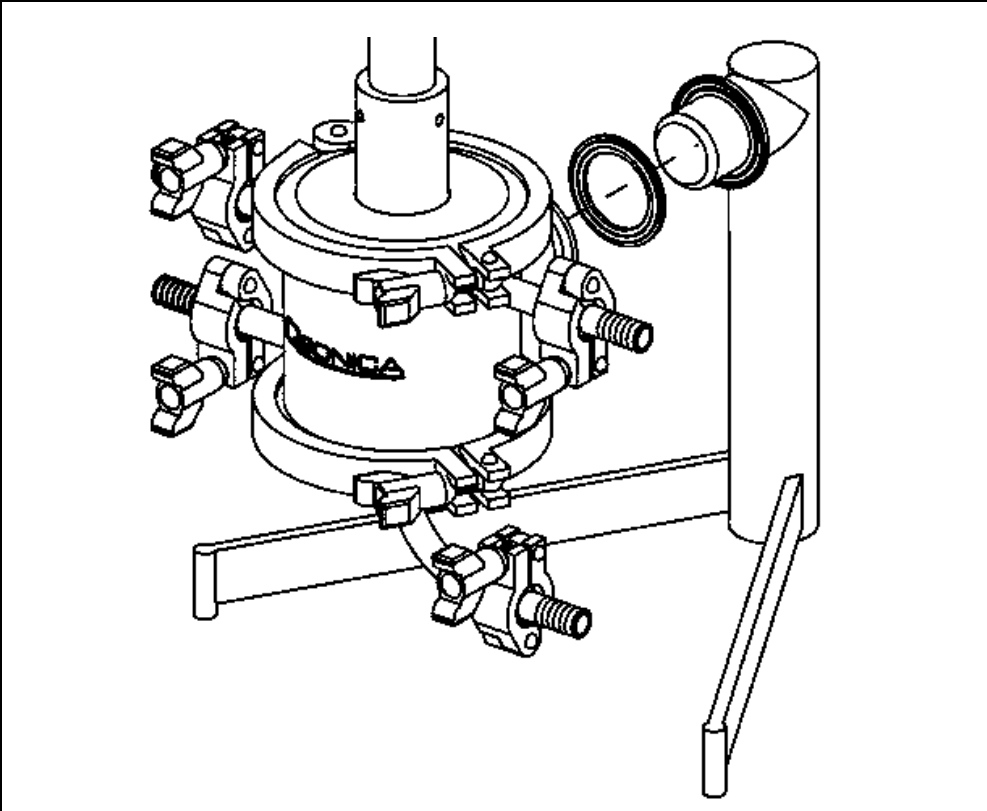

14. Insert gasket and floccell as shown.

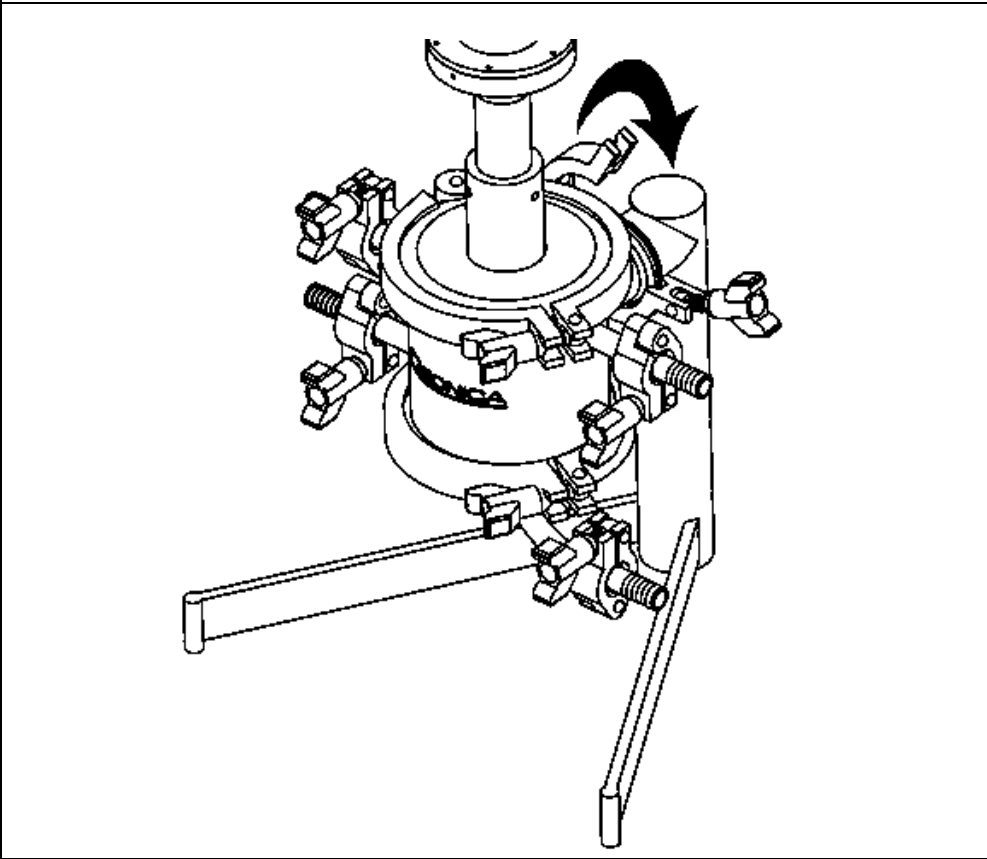

15. Lock tri-clamp

SECTION II – OPERATION

PRINCIPLES OF ULTRASONIC DISRUPTION

The ultrasonic electronic generator transforms AC line power to a 20 KHz signal that drives a piezoelectric converter/transducer. This electrical signal is converted by the transducer to a mechanical vibration due to the characteristics of the internal piezoelectric crystals.

The vibration is amplified and transmitted down the length of the horn/probe where the tip longitudinally expands and contracts. The distance the tip travels is dependent on the amplitude selected by the user. As you increase the amplitude setting the sonication intensity will increase within your sample.

In liquid, the rapid vibration of the tip causes cavitation, the formation and violent collapse of microscopic bubbles. The collapse of thousands of cavitation bubbles releases tremendous energy in the cavitation field. The erosion and shock effect of the collapse of the cavitation bubble is the primary mechanism of fluid processing.

Please consult with a product specialist for assistance with selecting a probe for your application.

Relationship of Amplitude and Wattage

Sonication power is measured in watts. Amplitude is a measurement of the excursion of the tip of the probe (probe is also known as a horn).

Some ultrasonic processors have a wattage display. During operation, the wattage displayed is the energy required to drive the radiating face of a probe, at that specific amplitude setting against a specific load, at that particular moment. For example, the unit experiences a higher load when processing viscous samples then when compared to aqueous samples.

The speed /cruise control on an automobile, can, to a certain extent, be compared to an Ultrasonic Processor. The speed/cruise control is designed to ensure that the vehicle maintains a constant rate of travel. As the terrain elevations change, so do the power requirements. The cruise control senses these requirements, and automatically adjusts the amount of power delivered by the engine in order to compensate for these ever changing conditions. The greater the terrain rate of incline and greater the resistance to the movement of the vehicle, the greater the amount of power that will be delivered by the engine to overcome that resistance and maintain a constant speed.

The ultrasonic processor was designed to deliver constant amplitude, to your liquid sample, regardless of these changes in load (much like the vehicle's cruise control described above). As a liquid is processed, the load on the probe will vary due to changes in the liquid sample (i.e. viscosity, concentration, temperature, etc.). As the resistance to the movement of the probe increases (increased load on the probe), additional power will be delivered by the power supply to ensure that the excursion at the

probe tip remains constant. The displayed wattage readings will vary as the load changes, however the amplitude will remain the same.

The resistance to the movement of the probe determines how much power will be delivered to maintain amplitude. For example, a 1/2" probe at 100% amplitude will require approximately 5 watts to operate in air. The maximum amplitude of this probe is approximately 100um. Insert the probe in water and the wattage reading will increase to approximately 90 watts. The wattage required to operate the probe will increase as the load increases but the amplitude remains the same.

The amplitude control allows the ultrasonic vibrations at the probe tip to be set to any desired level. Although the degree of cavitation/ultrasonic energy required to process the sample can readily be determined by visual observation, the amount of power required cannot be predetermined. A sensing network continuously monitors the output requirements, and automatically adjusts the power to maintain the amplitude at the preselected level. The greater the resistance to the movement of the probe due to higher viscosity, deeper immersion of the probe into the sample, larger probe diameter or higher pressure, the greater the amount of power that will be delivered to the probe. Setting the amplitude control to its maximum will not cause the maximum power rating of the unit to be delivered to the sample. The maximum power (2,000 watts) that the Ultrasonic Processor is capable of delivering will only be delivered when the resistance to the movement of the probe is high enough to draw maximum wattage.

It is the intensity of cavitation that determines the effectiveness of the sonication, not the total power applied to the system. Intensity is directly related to the amplitude of the radiating face of the tip or horn. It is amplitude that must be provided, maintained, and monitored. The unit provides controlled amplitude under varying load conditions in order to give reproducible results.

DIRECT PROBE SONICATION

Proper setup is important to optimizing the sonication amplitude settings and processing times. The probe should be securely held using the Qsonica stand and clamp. This clamp can be secured to either the booster ring or bottom of the converter.

Probe depth must be adjusted to ensure adequate mixing and sample circulation. Larger volumes and viscous samples will process more quickly and effectively with the addition of a mixer or stir bar.



Probe Depth Example:

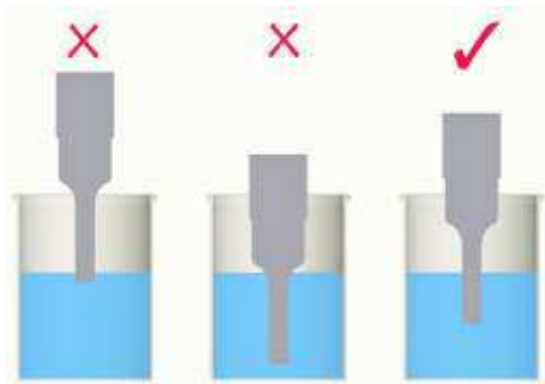

Probe depth is volume dependent.

Do not insert the #4777 probe deeper than indicated by the arrow. Contact us for guidance.



Probe Options:

Part #	Tip Diameter	Processing Volume Range*	Amplitude
4777	1.5" (38mm)	5 - 20L	100µm
4697	1" (25mm)	1 - 5L	100µm
4776	0.5" (12mm)	50 - 400ml	100µm

***Note:** Processing volumes are application specific. There are many variables (viscosity, concentration, etc.) that can affect the min/max processing volumes and processing times.

In addition, the amplitude setting needed for an application must be determined empirically.

Contact us for help with selecting the amplitude and time settings to begin your optimization trial.

Note: the booster cannot be used with ½" diameter tip probe #4776.

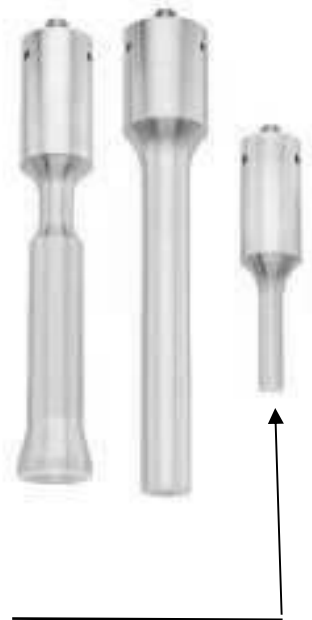

FLOCELL OPERATING CONDITIONS

Temperature

Sonication generates a significant amount of heat. Both the sample temperature and floccell body temperature must be managed.

Pre-cooling the product liquid before it enters the floccell is recommended. Inline cooling devices (like heat exchangers) and water jacketed vessels are good options. Temperature monitoring of the influent and effluent during processing is recommended.

Process liquid temperature – Maintain a temperature of 20°C or less

Water jacket temperature - Maintain a temperature of 5-20°C.

Note: The #4906 chiller can be used to help maintain coolant temperature within the water jacket. Depending on the application additional cooling will likely be needed.

Product Liquid Flow Rates

Process liquids must maintain a sufficient flow rate or the high power of the Floccell may prevent the liquid from flowing properly and cause an overload condition.

- **Amplitude** settings between **51-100%** require a minimum flow rate of approximately 1,250ml/min.
- **Amplitude** settings between **20-50%** require a minimum flow rate of approximately 500ml/min.

If an adequate flow rate is not maintained, the wattage reading on the system display will fall and the converter/booster/probe assembly temperature will rise. Eventually the system will display an overload error message. If you experience this please contact a Qsonica representative for more information.

Note: The above recommendations are for low viscosity, water based products with no particle load. High viscosity liquids or those that include particulate may require adjustments to the above recommendations. Please contact us for assistance.

If your process requires temperatures or flow rates outside the recommended range please contact us for assistance.

FUNCTIONS OF KEYS, CONTROLS, INDICATORS AND CONNECTORS

FRONT PANEL	
SCREEN	<p>Displays prompts and the following control parameters:</p> <ul style="list-style-type: none"> • Amplitude selected • Output power delivered to the probe in watts and as percentage of the total power • Selected duration of processing • Actual processing time • Elapsed time • Set and read temperature • Pulse duration • Amount of energy (Joules) delivered to probe.
0-9 key	Input digits.
CLEAR key	Clears preceding entry.
ENTER/REVIEW key	Enters data into the program, and selects various parameters for display on the LCD screen.
TIMER key	Used to set the duration of ultrasonic application – from 1 second to 9 hours, 59 minutes, 59 seconds.
TEMP key	Used with the numeric keys to set the high temperature limit – from 1°C to 99°C. Red indicator lights when the temperature limit has been reached. (optional temperature probe must be used for this feature)
PULSER key	Used with the numeric keys to set the pulse mode. The ON cycle and OFF cycle can be set independently from 1 second to 59 seconds. Red indicator lights when pulser is in the OFF portion of the cycle.
ENERGY key	Used to set the Energy Setpoint
START/STOP key	Starts or stops the ultrasonics. Red light indicates sonication.
PAUSE key	Suspends operation. Red light indicates Pause mode.
SAVE/RECALL key	Used with the numeric keys to assign a number to a program and store it in memory. Up to 9 programs (1-9) can be stored. Also used to recall any of 9 stored programs.
AMPL key	Controls the amplitude (intensity) of vibration at the tip of the probe.
key	Switches the main power ON.
O key	Switches the main power OFF.
▲▼ key	Used with the AMPL key to increase/decrease amplitude. To accomplish this task, depress the AMPL key to display the percentage of amplitude previously selected, then depress the ▲ or ▼ key as required

REAR PANEL	
Footswitch jack	Connects to the footswitch cable.
Coax connector	Connects to the converter
DB9 connector	I/O Connector
Electrical line cord	Connects to the 220/240V electrical outlet
Temperature probe jack	Connects to the optional temperature probe

I/O Connector Description

The following I/O connections are available for remote control and monitoring. This I/O interface provides remote monitoring and signaling to the Power Supply. Remote control can be used to vary the Amplitude, Command Sonics Start, monitor power output and frequency.

PIN	Name	Description
1	O.L. Indication (*1)	Output - Over Load Indicator. When a power supply overload has occurred this line will be set low referenced to pin 9. This is an open collector output. See schematic for ratings.
2	Not Connected	
3	Frequency Lock (*1)	Output – Frequency Lock Indicator. When the power supply has achieved frequency lock this line will be set low referenced to pin 9. This is an open collector output. See schematic for ratings.
4	Frequency Output / 10	Output – Square wave output representing the power supply frequency divided by 10. See schematic for ratings. This output is referenced to pin 9.
5	Power Output Watts	Output – Analog output representing power supply output wattage. 5.44mV = 1 Watt. See schematic for ratings.
6	Ground	Ground – Common reference point for pins 2, 5, 7 and 8.
7	Sonics Start	Input – Sonics Start signal. Apply a switch closure to ground (pin 6). This will start the ultrasonic cycle as programmed by the keypad. See schematic for ratings.
8	Amplitude Control	Input – Analog Input representing the Amplitude setting of the power supply. 0 to 10 VDC signal representing 20% to 100% amplitude. See Note 1. See schematic for ratings.
9	Common Emitter	Common reference point for pins 1, 3, and 4. See schematic for ratings.

Note 1. In order to activate remote amplitude control, the Amplitude Select switch on the Back Panel Interface PCBA must be set in the “External” position. To set the switch, power off the unit and disconnect the power cord from the wall socket. Remove the six screws holding the cover to the chassis. Set the switch to “External” on the Backplane Interface PCB. Re-install the cover and fasten all 6 screws. Re-connect the power cord to the wall socket.

Please contact Qsonica for specific applications assistance related to remote control and monitoring.

PREPARATION FOR USE

CAUTION

Do not operate an Ultrasonic Processor that has been in a very cold or hot environment for a prolonged period of time. Allow the system to reach room temperature before use.

1. Plug the electrical line cord into the electrical outlet. If the unit is already on, switch the unit off by depressing the  key.
2. If the optional footswitch is used, insert the footswitch plug into the jack located on the rear panel.
3. Complete the converter/booster/probe or floccell assembly as described on pages 10-18.

CAUTION

Never place a washer between the converter, booster or probe. Never apply grease to the mating surfaces or threads of the converter, booster or probe.

4. Connect the converter cable to the power supply. Connect one end of the converter cable to the connector on the rear panel of the power supply. Connect the other end to the converter. The connectors on the cable are interchangeable.
5. Connect the air fitting on top of the converter to a source of dry, filtered compressed air at 10 psi (5 CFM). **Air cooling is required.**

Converter Air Cooling

Sonication will cause both the probe and sample temperature to increase. The heat will transfer up to the converter. If the converter overheats the internal crystals can crack and the converter will require replacement. Converter damage due to overheating is not covered under warranty. Continuous processing applications require both chilling the sample and air cooling of the converter.

Cooling Air Regulation and Adjustment:

Adjust the regulated compressed air until the gauge indicates 10 ± 1 PSIG (approximately 5 CFM). The compressed air will flow into the converter and out through the bottom.

Note: The compressed air should be dry, oil free and filtered with a 5 micron filter. See page 12 for details.

USING THE ULTRASONIC PROCESSOR

CAUTION

Do not operate the power supply unless it is connected to the converter.

Press the **I** key on the front panel. The screen will display the power rating and the frequency of the Ultrasonic Processor, and the following control parameters.

TIME __:__:__	TEMP ____°C
PULSE ____	AMPL ____%

AMPLITUDE: Amplitude is the intensity of sonication and the only parameter that must be set in order for the Ultrasonic Processor to be operational. The other control parameters – Time and Pulse, do not have to be set for continuous operation. AMPL Displays the percentage of amplitude that was previously selected. Press the **AMPL** key and then use the numeric keys to enter the desired value. Then depress the **ENTER/REVIEW** key. For example, to enter a value of 40% amplitude, first depress the **4** key, then the **0** key and then depress the **ENTER/REVIEW** key.

The screen will display:

TIME __:__:__	TEMP ____°C
PULSE ____	AMPL 40%

The Ultrasonic Processor is now ready for continuous operation. To energize the equipment, press the **START** key or the footswitch. To de-energize the equipment, press the **STOP** key or release the footswitch. If the Time or Pulse* functions must be used, refer to the appropriate paragraphs(s) below.

To increase or decrease the amplitude in small increments when the equipment is on, depress the **AMPL** key to display the percentage of amplitude that was previously selected, then depress the **▲** or **▼** key, as required.

NOTE

Any combination of functions can be selected in any order. To clear an erroneous entry press the CLEAR key.

NOTE

If the **START** key is pressed and the time limit has not been set, processing will remain uninterrupted until the **STOP** key is depressed.

If the **START** key is pressed and the time limit has been set, processing will remain uninterrupted until the set time limit expires, or the **STOP** key is pressed – whichever occurs first.

If a footswitch is used, and the time limit has not been set, processing will remain uninterrupted as long as the footswitch is depressed.

If a footswitch is used, and the time limit has been set, processing will remain uninterrupted until the time limit expires or the footswitch is released – whichever occurs first.

The **START** key and footswitch are mutually exclusive. If the process is initiated by the **START** key, the footswitch becomes inoperative. If the process is initiated by the footswitch, the **STOP** key becomes inoperative.

1. Ensure the converter is being air cooled before starting sonication.
2. Immerse the probe into the liquid. Always immerse the probe deep enough below the surface of the sample to ensure effective mixing of your sample volume. Larger samples may require the probe to be submerged deeper. Contact your Qsonica representative with any questions.

If using a floccell accessory, make sure that the probe assembly is installed properly and then begin to flow liquid into the floccell before starting sonication.

3. Depress the **START** key.
4. Using the ▲ or ▼ keys, increase or decrease the amplitude as required.

TIMER: In the pulse mode the processing time will be different from the elapsed time because the processing time function monitors and controls only the ON portion of the duty cycle. For example, for 1 hour processing time, the elapsed time will be 2 hours if the Pulse timer is set for 1 second ON and 1 second OFF. To set the processing time, press the **TIMER** key.

The screen will display:

Time Setting
Hrs: __ Min: __ Sec: __

Using the numeric keys, set the processing time as required. For example, to enter a value of 15 minutes total sonication time, first depress the **0** key, the **1** key, the **5** key, the **0** key and then the **0** key.

Time Setting
Hrs: 0 Min: 15 Sec: 00

Press the **ENTER/REVIEW** key.

The screen will display:

TIME 0:15:00 TEMP ____ °C
PULSE ____ AMPL 40 %

PULSER: The pulse function enables the user to program the Sonicator to cycle ON and OFF during a set processing time. During the OFF mode the sample can cool. The pulse ON/OFF times depend on the amplitude setting used, sample volume and desired sample temperature range. If you require a low sample temperature and high amplitude you must chill the sample and use enough pulse OFF time to allow the sample temperature to drop sufficiently. The ON and OFF pulse duration can be set independently from 1 second to 59 seconds. During the OFF portion of the cycle, the red indicator on the **PULSER** key will illuminate. If the OFF portion of the cycle exceeds two seconds, a cautionary message – CAUTION – PROBE ON STANDBY – will warn the operator against touching the ultrasonic probe. To set the pulser, press the **PULSER** key.

The screen will display:

Pulse on ____ sec
Pulse off ____ sec

Using the numeric keys set the ON portion of the cycle, then press the **ENTER/REVIEW** key.

For example, to enter a value of 30 seconds ON, first depress the **3** key, then the **0** key and then depress the **ENTER/REVIEW** key.

The screen will display:

Pulse on 30 sec
Pulse off ____ sec

Using the numeric keys set the OFF portion of the cycle, then press the **ENTER/REVIEW** key.

For example, to enter a value of 15 seconds OFF, first depress the **1** key, then the **5** key and then depress the **ENTER/REVIEW** key.

The screen will display:

TIME 0:15:00	TEMP ____°C
PULSE 30 : 15	AMPL 40 %

TEMPERATURE (a temperature probe must be purchased to use this feature): The temperature function prevents overheating of the sample by continuously monitoring the sample temperature, and terminating the ultrasonics when the temperature reaches your setpoint. The ultrasonics is automatically reinstated when the temperature drops below the setpoint. If the temperature of the sample must be monitored and/or controlled, insert the optional temperature probe into the jack on the rear panel, immerse the temperature probe in the sample and press the **TEMP** key.

For example, the screen will display (or whatever the sample liquid temperature is):

Probe Temperature 27°C
Temperature Setpoint ____°C

Using the numeric keys set the high temperature limit (setpoint), then press the **ENTER/REVIEW** key.

For example, to enter a value of 35 degrees for the temperature set point, first depress the **3** key, then the **5** key.

The screen will display:

Probe Temperature 27°C
Temperature Setpoint 35°C

Press the **ENTER/REVIEW** key.

The screen will display:

TIME 0:15:00	TEMP 35°C
PULSE 30 : 15	AMPL 40 %

REVIEW: The REVIEW function provides a “window” on the process by displaying various operating parameters without process interruption. Pressing the **ENTER/REVIEW** key repeatedly during processing will consecutively display the following information.

- a) Selected amplitude:
e.g. Amplitude 40%
- b) Set processing time and elapsed processing time:
e.g. Set 0:15:00 Time 0:10:00
- c) Selected pulsing cycle, and actual pulsing cycle:
e.g. Pulse 30/15
- d) Amount of power in watts, and accumulated amount of energy in JOULES delivered to the probe:
e.g. 20 watts 0000000 Joules*
- e) Elapsed time since processing was initiated:
e.g. Elapsed time 0:10:00

NOTE

The amount of energy displayed will be only for one run. Initiating a new run will reset the display to zero.

**The number of Joules displayed is dependent on the watts being drawn and the processing time.*

ENERGY SETPOINT: The energy setpoint continuously monitors the amount of energy in Joules (watts-seconds), that is being delivered to the probe, and terminates the ultrasonics when the energy level reaches a predetermined setpoint. To set the energy setpoint, press the **ENERGY** key.

The screen will display:

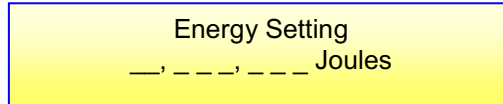

Energy Setting
_, ___, ___ Joules

Using the numeric keys, set the energy setpoint.

The screen will display:

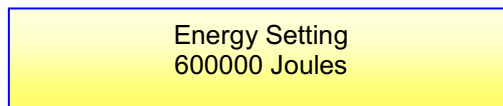

Energy Setting
600000 Joules

Press the **ENTER/REVIEW** key.

The screen will display:

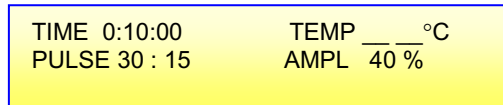

TIME 0:10:00 TEMP ___ °C
PULSE 30 : 15 AMPL 40 %

SAVE/RECALL

SAVE: The save function retains in memory up to 9 (1-9) control parameters under a storage identification (ID) number. To store the parameters under an ID number, press the **SAVE/RECALL** key.

The screen will display:

```
*RECALL JOB
SAVE JOB
```

Press the key one more time.

The screen will display:

```
RECALL JOB
*SAVE JOB
```

Press the **ENTER/REVIEW** key.

The screen will display:

```
S# T__:_:___ T___ °C
P ___ E __, __, ___ A ___ %
```

Using the 1-9 numeric keys, enter the ID number.

The screen will display:

```
S6 T__:_:___ T___ °C
P ___ E __, __, ___ A ___ %
```

Press the **ENTER/REVIEW** key.

The screen will display:

```
S6 TIME 0:10:00 TEMP ___ °C
PULSE 30: 15 AMPL 40%
```

RECALL: The recall function can retrieve from memory any of 9 stored control parameters for verification or usage. To retrieve any parameters press the **SAVE/RECALL** key.

The screen will display:

```
*RECALL JOB
SAVE JOB
```

Press the **ENTER/REVIEW** key.

The screen will display:

```
R# T__ : __ : __ T__ °C
P ____ E __ , __ , __ A ____ %
```

Use the 1-9 numeric keys, enter the ID number.

The screen will display:

```
R4 T__ : __ : __ T__ °C
P ____ E __ , __ , __ A ____ %
```

Press the **ENTER/REVIEW** key.

The screen will display:

```
R4 TIME 0:10:00    TEMP __ °C
PULSE 30 : 15    AMPL 40 %
```

Note: To review all the information that has been stored, press all the numeric keys consecutively.

SECTION III – SERVICE INFORMATION

Troubleshooting

Equipment Issue	Resolution
Ultrasonics is not turning on.	Check that the AC power cord is connected to the wall outlet and to the power supply. Check that the converter cable from the power supply to the enclosure is connected. Check that the internal converter power cable is connected to the enclosure and the converter. If problem persists, switch Off main power, wait 5 seconds and switch back On.
System makes high pitch or unusual noise when operated.	Disconnect converter and booster from horn and clean all mating and threaded surfaces using isopropyl alcohol. Properly reassemble tightly using the appropriate wrenches.
Power supply screen does not illuminate.	Check that the AC power cord is connected to the wall outlet and to the power supply. Check Fuses.
Display does not react to button press.	Switch Off main power, wait 5 seconds and switch back On.
Screen displays "OVERLOAD".	Press the OFF key to switch the unit off, and the ON key to switch the unit back on to restart the equipment. If the problem persists, check for likely causes in the bulleted list below. If the problem still persists, contact customer service (203)-426-0101.

Your Sonicator is designed for many years of dependable service but on rare occasions a problem may occur. Causes may include:

- The system is overheating.
- A connector or cable is damaged.
- The probe/booster/converter not tightened properly with the wrenches provided.
- Sample vessel is too small for the 1.5" probe. Use 5L vessel or larger.
- The convertor may have been dropped and damaged.
- A probe is worn out due to normal use and past its useful life.
- A fuse(s) has failed.
- Sample liquid viscosity is too high.

If the Ultrasonic Processor stops working, and an **OVERLOAD** indication is displayed on the screen, check for possible causes as outlined in the above paragraph.

Note: Most faults can be solved by cleaning all mating and threaded surfaces using isopropyl alcohol and properly re-assembling tightly together using the appropriate wrenches. Follow the tightening procedure in the assembly instructions.

If the problem persists after inspecting all of these options, please contact us for support.

Maintenance

It is recommended to periodically inspect the unit, both visually and physically, to insure optimum and safe performance. This inspection should be scheduled as a routine maintenance procedure, done with the unit power **OFF** and with the unit unplugged from the AC power source.

Long exposure to acids or caustics results in corrosion of metal parts or components. Check the generator, converter, and cables periodically for any signs of rust or discoloration. If discoloration is found, move the ultrasonic processor away from the source of the contaminant.

Examine the condition of the high voltage cable that attaches the converter to the generator. Inspect the wire insulation for damage, such as wear, burning from hot plate contact or breakage from extended use or rough handling. In general use, the cable assembly should not be used to carry the converter or pull it toward the user. Make certain the cable always has slack and is never tensioned. If necessary, move the generator or converter assembly closer to one another to accomplish this. If this is not possible, contact your Customer Service Representative to obtain a longer cable.

WARNING: Do not use a cable with broken end connections, exposed wires or frayed insulation. High voltage is present in the cable and will pose a shock hazard. Do not touch the converter assembly until the power switch is off and the unit is unplugged.

Probe Maintenance

While operational, the converter-probe assembly should be supported properly and the probe tip should be suspended to vibrate freely in a liquid. The sides and end of the probe must **never** be allowed to come in contact with anything but the liquid solution.

Proper care of the probe is essential for dependable operation. During normal use the tip of the probe to erode. For that reason, **it is recommended that a Preventative Maintenance (PM) schedule be adopted to examine the unit at regular intervals.**

The PM schedule should depend on frequency of use. Weekly maintenance schedules are recommended for units used frequently or monthly for those used less often. The tip must be examined for excessive wear and to ensure that the threaded connection is clean and attached properly to the convertor. See probe tightening instructions if necessary.

When excessive wear (corrosion/pitting of the probe tip) is detected the probe should be replaced before performance is diminished.

Note: *A loose converter-booster-probe assembly will usually generate a loud piercing or squealing sound.*

WARNING: Hand-tightening horns onto the convertor is not sufficient; properly tighten them with the appropriate Wrench Set. See the steps on pages 10-18 for attaching and detaching probe assemblies.

System Cleaning Instructions

The generator and converter may be cleaned using an acid-free cleaning solution (i.e. glass cleaner) and a soft cloth.

Probes should be cleaned using isopropyl alcohol. Probes are made from titanium and can be autoclaved (the converter is an electrical part and cannot be cleaned in this manner). Before each procedure place the probe tip in water or alcohol and turn the power on for a few seconds to remove residue. The tip also can be cleaned using alcohol with the power on.

RETURN OF EQUIPMENT

If the unit is in need of repair it can be sent back to the factory.

Please obtain a **Return Authorization Number** (RA#) prior to returning the instrument.

A unit received without a Return # will not be repaired.

In order to receive prompt service; always contact the factory before returning any equipment. For equipment not covered by the warranty, a purchase order should be forwarded to avoid unnecessary delay. We recommend using the original packaging to insure against damage in shipment. The equipment should be sent to the "Service Department" with all transportation charges prepaid and return of shipment indicated.

SAFETY CERTIFICATION FORM

Federal law prohibits the transfer of equipment or products contaminated with radiological, biological or chemical waste residue. Qsonica requires that each customer certify one of the statements on page 39 prior to returning any equipment. Please print a copy of the form on page 39, fill it out and send it back with the equipment being returned.

This form must accompany any equipment that is being returned for repair.

QSONICA SAFETY CERTIFICATION FORM

Items being returned:

Please check only one item below:

The equipment was never used or exposed to any radiological, biological or chemical agents and is safe to handle, use or dispose of.

The equipment was used but not in conjunction with or exposed to any radiological, geological or chemical agents and is safe to handle, use or dispose of.

The equipment was used in conjunction with or exposed to radiological, biological or chemical agents and has been decontaminated, rendering it safer for handling, use or disposal.

Authorization

By accepting authorization to return the equipment listed above, the undersigned assumes all responsibility and liability for radiological, biological and chemical decontamination. Qsonica reserves the right to refuse delivery of the equipment without necessary documentation or where we determine they have not been properly decontaminated. Qsonica reserves the right to bill the customer for any and all costs associated with the decontamination and/or disposal of the equipment we determine was not properly decontaminated. In the event the equipment has been exposed to radiological contamination, the signature of the Radioactive Safety Officer is required.

Print name: _____ RA# _____

Signature: _____ Date: _____