



Linkam Scientific Instruments

MDS600

Motorised Temperature Controlled Stage

USER GUIDE

Contents

Before Setting Up Your Equipment.....	3
Important Notice.....	4
Warranty.....	4
Technical Support.....	4
Equipment Maintenance.....	4
Handling Liquid Nitrogen.....	4
Feedback.....	4
Safety Precautions.....	5
Symbol Reference.....	5
Introduction.....	6
MDS600 Stage Specification.....	6
MDS600 System.....	6
Stage Anatomy.....	7
Stage Assembly.....	7
Lid Assembly.....	7
Mounting Stage to Microscope with Dovetail Substage.....	8
Setting up the Condenser For Koehler Illumination.....	7
Vacuum Tweezers.....	9
Connecting the Instruments.....	10
T95 System Controller Cable Connections.....	10
LNP95 Cooling Pump Connection.....	11
Remove Transit Screws.....	11
Back Panel Cable Connection.....	11
Setting Up ECP Water Circulator Pump.....	12
Sample preparation.....	13
MDS/CC Crucible Carrier and Quartz Crucible.....	13
MDS/CC Crucible carrier and Stainless Steel Ring.....	14
Cooling Connections.....	16
Purging Procedure.....	17
Use LinkPad to set the LNP95 to Manual Mode.....	17
Filling the Liquid Nitrogen Dewar.....	17
Purging the Stage Method 1.....	18
Purging the Stage Method 2.....	19
Using Linksys32 Software with MDS600 Stage.....	20
Motorised XY Control.....	20
MDS Setup Menu.....	21
Using LinkPad with MDS600 Stage.....	22
Appendix.....	23
Replacing MDS/CC Crucible Carrier.....	23
G10MT Sample Holder and Sample Mapping.....	25
G10MT Sample Holder and Quartz Sample Window.....	25
Sample Preparation Using G10MT Sample Holder.....	26
Sample Mapping Using Linksys32 Software.....	27
Window Assembly.....	30
Lid Window Assembly.....	30
Bottom Window Assembly.....	30
Spares and Accessories.....	31
Troubleshooting.....	33
Contact Details.....	36

Before Setting Up Your Equipment

Please register your products by going to www.linkam.co.uk and click on the product/software registration button.

You will need to register your equipment with us to:

- Activate your warranty and technical support
- Access the online setup videos
- Permanently unlock the Linksys32 software (if purchased)

If you have purchased Linksys32 software, please install the software first. This process will guide to register all of your products.

See Linksys32 manual for further installation instructions.

A CD with a setup videos is supplied with your system.

Important Notice

Please check that your Linkam equipment has not been damaged during transit. If there is any evidence of external damage **DO NOT SWITCH ON ANY ELECTRICAL ITEMS**.

Contact LINKAM SCIENTIFIC or their appointed distributor immediately. Your warranty may be impaired if Linkam is not informed of any transport damage within 7 working days of delivery.

NO attempt should be made to repair or modify the equipment in any way, as there are **no user replaceable parts**.

No attempt should be made to open the case except by qualified personnel as hazardous voltages are present.

In order to use this equipment successfully, please take time to read this manual all the way through before using it.

Warranty

This equipment has a warranty against defects in material and workmanship for a period of 12 months. Linkam will either repair or replace products that prove to be defective. For warranty service or repair, this product must be returned to Linkam or a designated service facility.

The warranty shall not apply to defects resulting from interfacing, unauthorized modification or misuse, operation outside of the environmental specifications for the product, or improper site preparation or maintenance.

Technical Support

Any technical questions or queries should be addressed to the Technical Support Department at the address shown on the back of this manual.

Equipment Maintenance

Use a small quantity of isopropyl alcohol with a soft cloth and gently wipe the surface. To clean the hot-stage, use isopropyl alcohol (IPA) and cotton swabs. Take great care not to touch the platinum temperature sensor protruding from the side of the heating element. The sensor is very fragile.

Handling Liquid Nitrogen

To cool samples below room temperature a LNP95 liquid nitrogen pump is required. Please refer to your health and safety manual for instructions on how to handle liquid nitrogen safely. The Dewar supplied with the LNP95 has a safety release valve built into the siphon assembly. Always use in a well ventilated room.

Feedback

Your feedback will be greatly appreciated, please go to www.linkam.co.uk to fill in the Feedback form.

Safety Precautions

- 1) Read this guide before using the equipment. Save these instructions for later use.
- 2) Follow all warnings and instructions which may be placed on the programmer or stage.
- 3) If for any reason the mains fuse needs to be replaced then it must be replaced by one of the same type and rating as shown in the equipment ratings.
- 4) To prevent electric shock, do not remove the cover of the controller or associated electronics.
- 5) Never use the equipment if a power cable has been damaged. Do not allow any heavy objects to rest on the power cables. Never lay the power cables on the floor.
- 6) Do not obstruct any ventilation holes. Do not attempt to insert anything into these openings. Provide adequate ventilation of at least 75mm all around the equipment.
- 7) Do not expose the equipment to water. If for any reason it gets wet then unplug it from the mains and contact Linkam Scientific Technical Support.
- 8) The equipment is not intended to be used outdoors.
- 9) Each product is equipped with a 3-wire grounded (earth) mains plug or a free-end 3 wire mains lead. The plug only fits into a grounded-type outlet. The free-end mains lead should be connected to a correctly grounded 3-wire mains outlet. Do not defeat the purpose of the grounded (earth) type plug.

Free - end mains leads are colour coded as follows :

Colour	Function
Brown	Live
Blue	Neutral
Green/Yellow	Earth (Ground)

- 10) If any problems occur then unplug the equipment from the mains outlet and contact Linkam Scientific Technical Support.
- 11) Do not remove the cover from the equipment unless the mains inlet has been removed. Any servicing should be carried out by qualified service personnel.

Symbol Reference

Caution:

This safety symbol is on the back panel of the equipment and warns:-



The user must not make or remove any connections while the unit is powered on. To avoid electric shock do not remove the cover. Refer servicing to qualified service personnel.

Caution:



This warning symbol indicates that the surface labelled with this symbol may be hot.

Introduction

Thank you for purchasing the MDS600 motorised temperature controlled stage system. Please take the time to read through the manual as it will help you to make the most out of the equipment.

Visit our website (www.linkam.co.uk) to register your equipment, this will ensure that we can update you if there are any firmware updates available to your System Controller and/or Linksys32 software

MDS600 Stage Specifications

Maximum temperature:	600°C
Minimum temperature:	-196°C
Maximum heating rate:	150°C/min
Objective Lens WD:	4.6mm
Condenser lens WD:	12.5mm
XY travel distance:	15mm
Maximum Speed:	6000µm/s
Minimum speed:	0.1µm/s
Aperture hole:	2mm
Weight:	1.2Kg

MDS600 System

The system consists of a MDS600 stage, a T95-LinkPad System Controller, a LNP95 liquid nitrogen cooling pump system and Linksys32 software.

Linksys32-DV (digital video) or Linksys32-AV (analogue video) video capture software can be added as an option.

Please install the Linksys32 software first and activate the licence key. See Linksys32 manual for more information.

The MDS600 stage is mounted onto the microscope by using either specific stage clamps or an adaptor plate.



MDS600 System

Stage Anatomy

Stage Assembly

1. Stage body water connector
2. XY Motor cables
3. Gas purge valve
4. Liquid nitrogen cooling connector
5. Manual X-Manipulator thumbscrew
6. X- manipulator motor
7. Y-manipulator motor
8. Manual Y-Manipulator thumbscrew
9. Stage body
10. Lemo connector for stage lead
11. Gas purge valve
12. Stage body plate cover screw

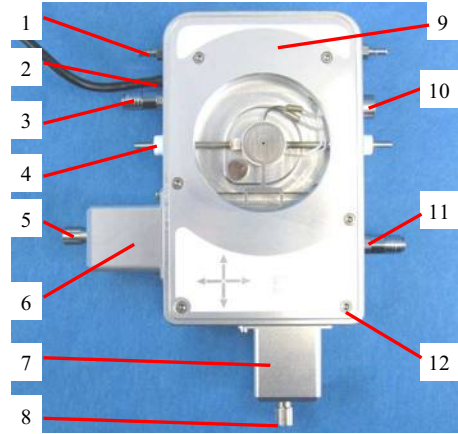

13. Stage chamber
14. Seeding post. Only available for MDBCS196
15. Stainless steel cooling tube
16. Warm post. Only available for MDBCS196
17. Sample carrier (MDS/CC)
18. Heating element wire
19. Platinum temperature sensor
20. Aperture hole
21. 22mm diameter pure silver heating block

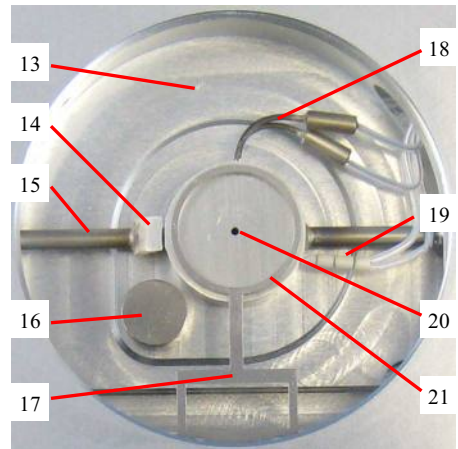

Lid Assembly

The Stage Lid is removed from the stage by unscrewing anti-clockwise.

22. Stage Lid
23. Lid Insert
24. Viewing Window (22 x 0.17mm glass)
25. Holes for Tube Clip Holder or window removal tool

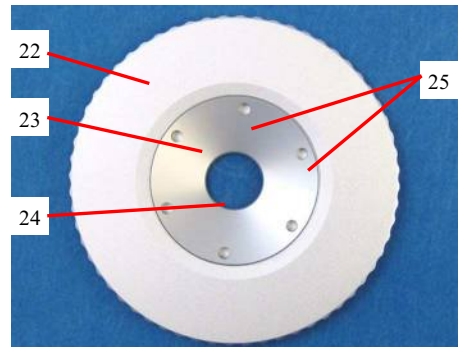

Mounting Stage to Microscope with Dovetail Substage

The following description is for mounting the stage on to microscopes which have a circular dovetail substage assembly (1).

Attach the curved stage clamps (part no. 9541) to the base of the stage using the supplied hex screws and the outer most holes in the base plate.

Adjust the two positioning thumbscrews (2) and locking thumbscrew (3) so that approximately 5mm of thread is exposed on the inside edge of the clamp. This will roughly position the stage in the centre of the dovetail.

Place the stage onto the dovetail, then focus a 10X objective lens on the aperture of the silver block. Using the two positioning screws (2) ensure that the aperture is in the centre of the field of view and lock the stage in place by tightening the Locking Thumbscrew (3).

For other types of microscope substage, refer to the diagram included with the stage adaptor.

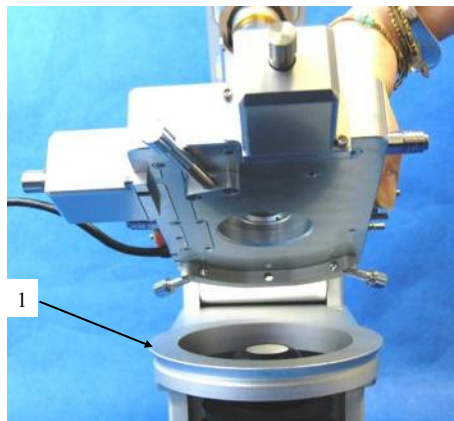
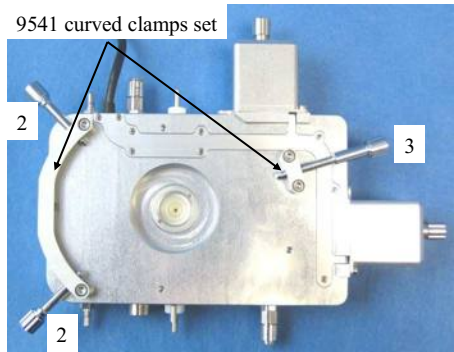

Linkam Imaging Station with dovetail substage

Setting up the Condenser for Koehler Illumination.

Place a small sample on a cover slip and place onto the surface of the silver block. Use a 5X or a 10X lens to focus on the sample. Now close down the microscope field diaphragm and adjust the condenser focus so that the edges of the diaphragm are in focus. Now use the condenser positioning screws to centre the condenser in your field of view. Open the diaphragm so that it just fills the field of view.

For more information about Koehler illumination see the extremely informative 'Microscopy Primer' on the Molecular Expressions website.

<http://micro.magnet.fsu.edu/primer/index.html>



Vacuum Tweezers

The vacuum tweezers are used to manipulate the sample windows onto the silver block to prevent fingerprints on the glass and scratching the surface of the silver block when using standard fine tip metal tweezers.

The System is supplied with a Vacuum Tweezers Kit which consists of a Vacuum Pump (1) and tweezers (2).

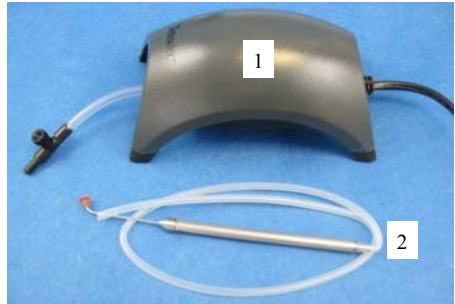

Connect the tubing at the end of the tweezers to the Regulator Valve (3) connection.

Use the dial on the valve to adjust the vacuum for the tweezers.

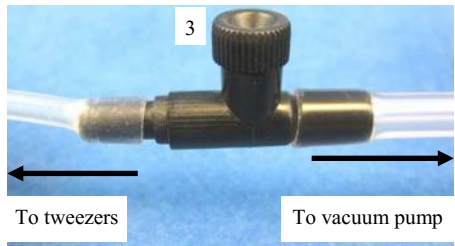

Use a finger to block the hole of the tweezers to pick up a sample cover slip with the suction cup.



Release the finger to drop the sample cover slip.



Connecting the Instruments

T95 System Controller Cable Connections

For more details on the T95 System Controller please refer to the T95 System Controller manual.



T95 back panel

Connect the Stage Cable to the Lemo Connector on the stage and connect the other end to the Stage Connection Socket (1).



Connect the cable from the stage labelled 'MOT X' to Slot 1 of the T95; labelled 'MOT X' (2).

Connect the cable from the stage labelled 'MOT Y' to Slot 2 of the T95; labelled 'MOT Y' (3).

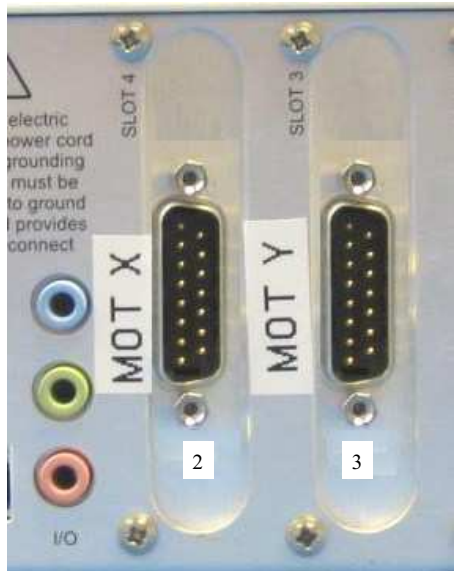

LNP95 Cooling Pump Connection

Remove Transit Screws

Before using the LNP95 Liquid Nitrogen Pump System, remove the 4 transit screws, marked by small yellow labels, from the base of the LNP95. Transit screws shown by arrows in the adjacent image. These screws hold the pumps in place for shipping.

Keep the screws safe by screwing them into the holes on the back panel as shown by the arrows.

The screws must be replaced back into the transit holes on the base, when shipping back to Linkam for service or repair.

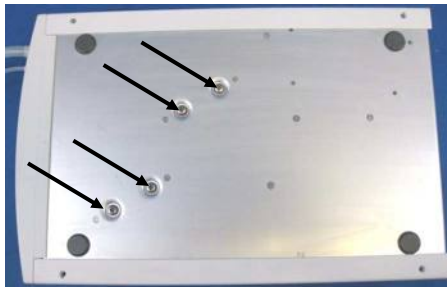

Back Panel Cable Connection

Connect the Instrument Bus Cable (2) between the LNP95 and T95 as shown.

Note: either of the purple coloured Instrument Bus Sockets on the LNP95 can be used.



Important: THE LNP95 MUST BE SWITCHED ON BEFORE T95 SYSTEM CONTROLLER

Setting Up ECP Water Circulator Pump

If you have purchased the ECP with the system, read the following to set up the ECP with the MDS600 stage. Refer to the ECP manual for more details.



When heating the stage above 300°C for a prolonged period of time, the metal casing body of the stage can get quite hot. Connect the tubing from the ECP as shown in the opposite picture to cool the stage.

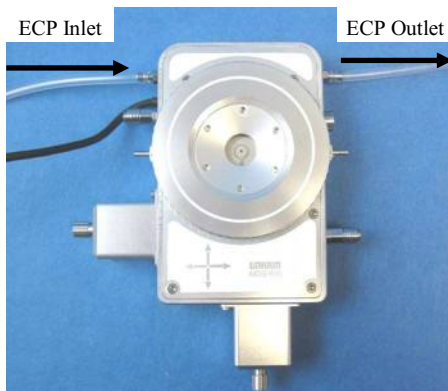

Note: the performance of the stage is not affected whether the ECP is in use or not.

Note: If you have an LNP95 Liquid Nitrogen Cooling system, the tubing from the Dewar must not be connected to the MDS600 stage when heating above 300°C. The thin black capillary tube will melt inside the heater and damage it.

Sample Preparation

For accurate results it is most important that the surface of the block, window and carrier are extremely clean, since air gaps between the silver block and the sample window will result in temperature errors.

The block is made of silver and since it is a soft metal it can get scratched easily especially by using sharp fine tweezers. This can cause a ridge to form which prevents the sample window from sitting flat on the block with the resulting air gap causing significant temperature errors.

For this reason we recommend that the sample and windows are always handled using the Linkam Vacuum Tweezers.

MDS/CC Crucible Carrier and Quartz Crucible

The MDS/CC sample holder (1) is used to load larger volume liquid samples using the Quartz Crucible.

The MDS/CC is fitted on to the MDS600 stage and hovers a few millimetres above the silver heating block.

Place the quartz crucible (2) into the MDS/CC sample holder by placing the crucible into the aperture at the end of the holder. Tap the edge of the crucible and make sure the crucible sits flat on top of the silver block.

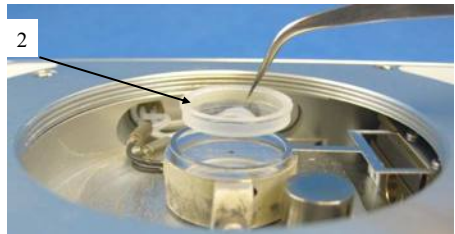

Pipette the sample into the Quartz Crucible. Use as little sample as possible to ensure a small thermal load and therefore better temperature sensitivity.

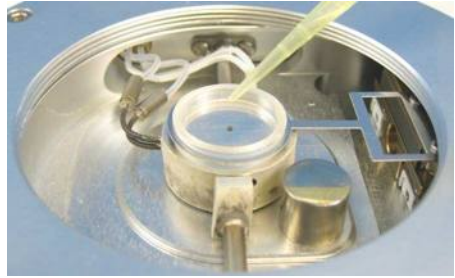

Place a W13G (13 x 0.17mm) (1) glass cover slip on top to flatten the sample.

Microscope objectives require a flat surface to give maximum field of view.

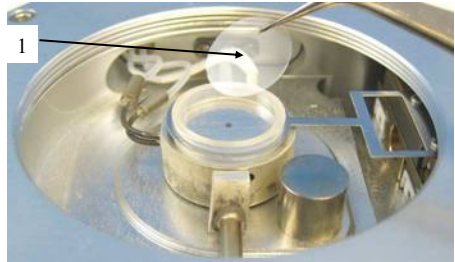

MDS/CC Crucible Carrier and Stainless Steel Ring

This sample loading method is likely to be more routinely used than the Quartz Crucible as the 16mm glass sample cover slips can be discarded after each experiment.

Place the Stainless Steel Ring (2) within the MDS/CC.

Tap the edge of the ring lightly to ensure that it has dropped through the aperture of the MDS/CC and sits properly on the surface of the silver block.

It is critical that the ring is able to move freely inside the aperture of the sample holder and sits flat against the surface of the silver block.

The Stainless Steel Ring is used to push the 16mm cover slip around the surface of the block when using the motorised XY manipulators.



Use the vacuum tweezers or a pair of tweezers as shown and place a W16G (16 x 0.17mm) (1) glass cover slip (1) into the stainless steel ring.

Tap the edges lightly to ensure that it sits flat against the surface of the block. If the cover slip does not sit perfectly flat against the temperature controlled surface the heat flow will be compromised and the sample temperature will be significantly different to the displayed temperature. The Stainless Steel Ring is used to push the 16mm cover slip around the surface of the block when using the motorised XY manipulators.

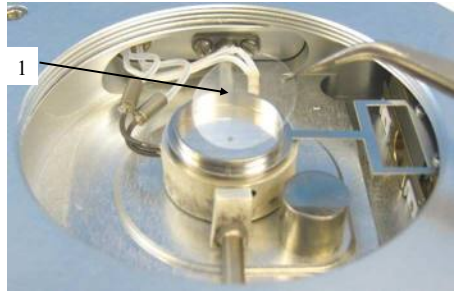

Using a pipette or tweezers or spatula place the sample on the 16mm cover slip. Ensure that the sample is as small as possible and that it is as flat as possible. Heat flow into or out of the sample is affected by the amount of sample area in contact with the temperature controlled cover slip.



Place a second 16mm cover slip on top of the sample and gently tap the top with the back of the vacuum tweezers to disperse powder samples to ensure good thermal contact of irregularly shaped samples and to create a flat surface for the microscope lens to focus on.

Accurate temperatures can be obtained by keeping the sample as small and flat as possible.



Cooling Connections

These connections need only be made if the experiments are to be carried out below room temperature.

The Dewar siphon (1) is the thick white foam tubing and is attached to the liquid nitrogen Dewar. The thin black capillary tube inside the white foam tube must be inserted into the liquid nitrogen cooling connectors on the stage.

The white tubing slides on to the outside of the connector. Twist the siphon whilst sliding it on and push until it comes to a stop. It does not need to go all the way to the base of the connector.

The thicker silicon tube from the LNP95 cooling pump ends in a white PTFE connector (2), this is pushed over the end of the other stainless steel connector as seen in the image.

The short tube branching from the side of this white connector is the Gas Purging Tube (3). There is a valve opening Insert connector (4) inserted into the end of this tube. During the purging procedure, insert this connector into the Gas Purge Valve (5) on the side of the stage to open it.

The Gas Purge Valve (5) is opened when the Gas Insert (6) is pushed firmly into the connector, a “click” is heard when the two parts are connected properly. To remove the Gas Insert, push the outer sleeve of Gas Purge Valve toward the stage and the Gas Insert (6) should drop out.

There is a second Gas Purge Valve on the opposite side of the stage to allow the gas to leave the stage. A Gas Insert must also be inserted into this Gas Purge Valve (7) when purging.

The smaller tube from the outlet on the LNP95 should be placed in position on the top of the lid using the Tube Clip Holder (8). This tube blows warm recycled nitrogen gas across the lid window to prevent condensation on the viewing window surface.

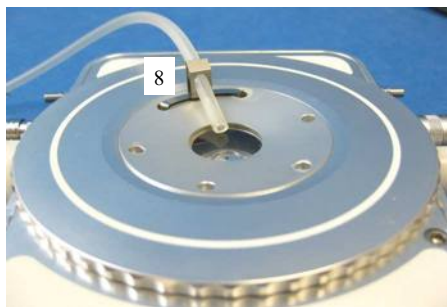
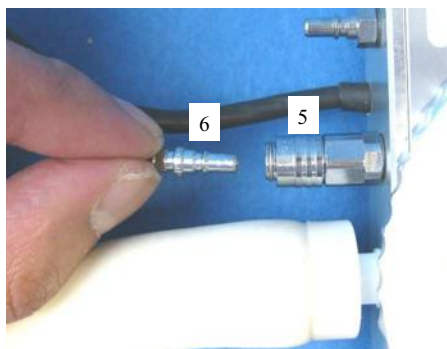
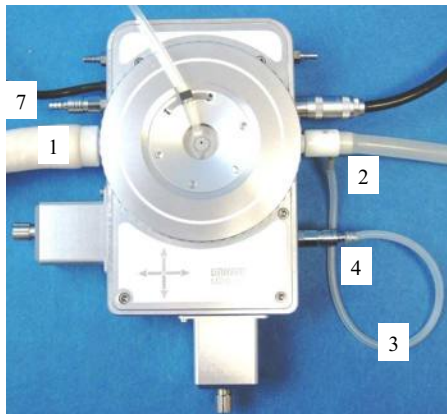

Purging Procedure

Before starting a cooling experiment, you will need to purge air from the stage chamber with dry nitrogen . This will remove the water in the air which would otherwise condense and freeze on the sample disrupting your image quality.

Before you can start purging, the LNP95 must be set to manual mode.

You can either use the LinkPad touch screen or Linksys32 software.

Use LinkPad to set the LNP95 to Manual Mode

Touch the active area (1) under 'Lnp speed' to change to the LNP Screen Menu. Touch 'Man' (2) to switch the LNP95 to manual mode.

The word 'auto' is changed to 'speed' to indicate the LNP95 is functioning in manual mode.

Using the Keypad type in 100 (max pump speed) and touch the 'Enter' button (4) to start the LNP95 at the programmed speed (5).

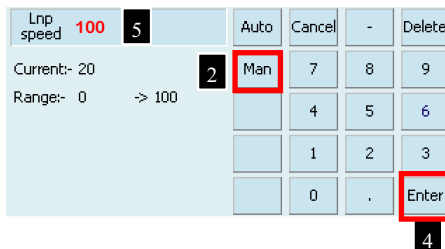
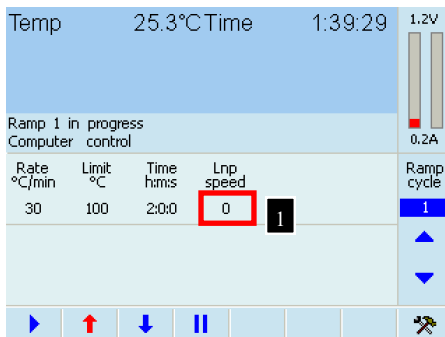

Filling the Liquid Nitrogen Dewar

Please follow your health and safety manual for directions on how to handle liquid nitrogen and ensure that you have the correct safety equipment including gloves and safety goggles.

Fill the Dewar until approximately 2/3 full and replace the lid with siphon attached.

DO NOT FASTEN THE CATCHES.

Wait for the nitrogen to stop bubbling before fastening the catches.

Take care when placing lid on a table to always have the black capillary pointing upwards. It is easily damaged which will impair N₂ flow.

Purging the Stage Method 1

There are two methods for purging the stage. Method 1 uses recycled nitrogen gas produced by the LNP95 from the 2L Dewar.

1. Make sure the stage lid is in place and the stage door is closed.
2. Switch on the temperature programmer and set the limit to 40°C. Press the START button and wait until the temperature limit is reached. Press HOLD to hold the temperature at 40°C.
3. Switch on the LNP95 cooling system and set it to manual mode, (see page 17) and set the speed to maximum of 100.
4. Check that the Gas Inserts are locked into place
5. Using a finger on the left hand, block the hole in the white plastic pump connector found on the perpendicular side to the purging tube. Still working with the left hand, pinch the narrow window tube to block it. This action will divert all of the nitrogen gas to the Purging Tube and through the Stage Chamber.
6. With the nitrogen gas flowing through the Sample Chamber, use a finger on the right hand to block the gas outlet for a few seconds to allow pressure build, then release the gas . Do this for a few minutes to purge the stage.
7. Look at the change of reflection in the stage window as the stage is pressurised and released to check that the stage is properly sealed. If there is no change, there may be a leak due to incorrect placing of the silicon o-rings in either the bottom or lid window or the window (top/bottom may be broken).
8. The purging procedure allows mixing of nitrogen gas with the residual air inside the Sample Chamber. By pressurising the chamber with nitrogen gas and releasing it, the air inside the Chamber is being diluted with the nitrogen gas.
9. Remove the two Gas Inserts and unblock the pump connector and window tube.
10. Change the LNP95 to **AUTOMATIC** mode so that the T95 automatically controls pump speed during your cooling experiment
11. Go to www.linkam.co.uk and register your equipment to see videos of how to purge and more.

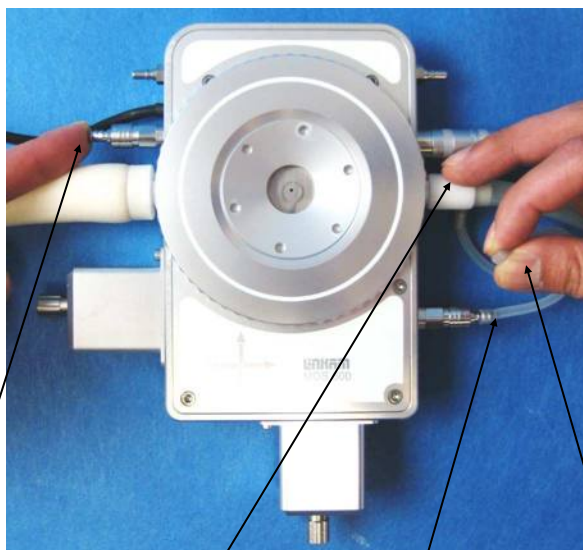

Block and release outlet valve with finger

Block hole in Connector with finger

Purging tube

Pinch window tube with right hand

Purging the Stage Method 2

This method uses an inert gas from a gas cylinder to purge the stage at temperatures above ambient when the LNP95 is not required.

1. Make sure the Stage Lid is in place and the Stage Door is closed.
2. From a gas cylinder connect the Gas Insert with a tubing 3mm inner diameter and 6mm outer diameter to the Gas Purge Valve (1).
3. Connect a Gas Insert to the opposite side Gas Purge Valve (2).
4. Use the gas regulator to set a gas flow rate of 1.5L/min.
5. With the gas flowing through the Sample Chamber, block the gas outlet for a few seconds and releasing the gas outlet valve with a finger. Do this for a few minutes to purge the stage.

Reduce the gas flow rate to 20cc/min to continuously purge the stage or remove the two Gas Inserts to keep the chamber under closed inert atmosphere.

Note: Helium gas is not recommended for continuous purging. This gas has a very high thermal conductivity and will cool the silver heating block too much during an experiment and may cause the temperature to fluctuate.

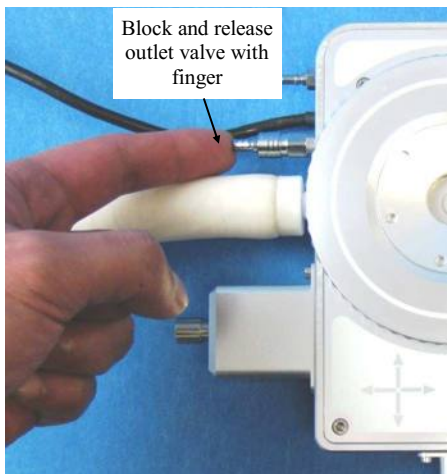
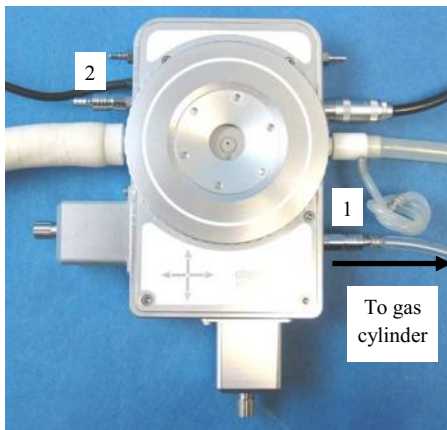

Using Linksys32 Software with MDS600 Stage

Please refer to Linksys32 manual to control the temperature of the MDS600. With Linksys32-DV/AV for digital video/analogue video capture. The following chapter will provide extra information to control the motorised XY manipulators using Linksys32 software and automatically map a sample using Linksys32-DV/AV software with a camera.

Motorised XY Control

When connected there is an additional Motorised Tool Bar (1) in the main screen of Linksys32.

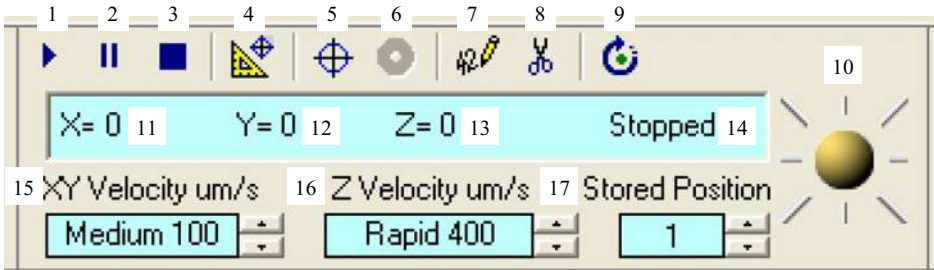

1. **Goto Position**, continue a paused step move or stored position move
2. **Pause Motion**, pause a step move or stored position move
3. **Stop Motion**, stop a step move or stored position move
4. **Goto Reference**, move to the reference position
5. **Goto Stored Position**, move to the displayed Stored Position
6. **Goto Post**, move to the Warm Post when using G7MTB Sample Holder. Only available for MDBCS196
7. **Save the Current Position**, saves the current XY values into the displayed Stored Position
8. **Delete the Current Stored Position**, deletes the XYZ values stored in the displayed Stored Position
9. **Change Motion to Step Move / Change Motion to Freely Move**, Used to change to joystick operation between step and free movement (step size is setup in the MDS setup table)
10. **Joystick**, hold the mouse left button down and move the mouse around to move in X and Y
11. **X Position**, display the current X position
12. **Y Position**, display the current Y position
13. **Z Position**, inactive with MDS600
14. **Motor Status**, Status of XY Motor, Stopped or Moving
15. **XY Velocity**, speed selection for XY motors. Use the up or down arrow / Nudge Control to select a preset Speed (Fine, Medium or Rapid), see MDS Setup Menu, page 20
16. **Z Velocity**, inactive with MDS600
17. **Stored Position**, stored position number selected (1-150), use the up or down arrow / Nudge Control to select the stored position number

MDS Setup Menu

X-Y

Right Click on the MDS controls tool bar to open the MDS Setup window. Click on the 'X-Y' option to setup the three speed ranges for the X and Y motors (**Fine**, **Medium** or **Rapid**). The nudge controls on the toolbar will enable speed changes within these ranges. When step mode is selected the XY motors will only move one step at a time. You can determine the size of the step by typing a value in the box labelled '**Step Movement um**'. The default is 100µm.

Note: The last two buttons labelled '**Diagonal**' and '**Square**' are for testing purposes only. DO NOT USE.

Focus (Z)

This option is not implemented with the MDS600 Stage, DO NOT USE.

Sample area

There are a number of different sample holders for the different versions of the motorised stage.

You must select which sample holder you are using from the following setup menu. If the incorrect sample holder is selected the MDS stage will not have the correct XY displacement information for the specific sample holder. The MDS/CC Crucible Carrier used the G16 Sample area holder

Set Reference Point

Each time you start working with the MDS600 stage you will need to set an approximate reference point. This is when the centre of the sample holder is in the centre of the block. Click on the button at the bottom of the setup menu when the sample holder is in the correct position. X and Y values will be set to Zero in the MDS tool bar Data window.

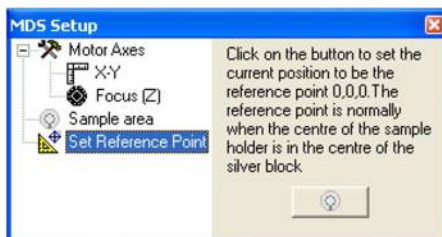
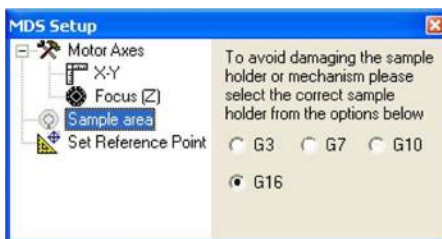
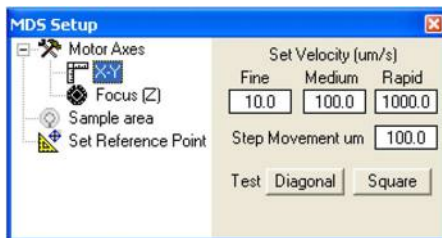

Using LinkPad with MDS600 Stage

It is not possible to control the motorised X and Y using LinkPad.

The LinkPad works as a standalone unit. It is not possible to program the temperature using LinkPad when Linksys32 software is connected.

Please refer to T95 System Controller manual to program the temperature using LinkPad.

With Linksys32 connected and running, the LinkPad become an active screen and displays information from Linksys32 Software.

With the MDS600 connected the main screen of the LinkPad will display the live position of the X (1) and Y (2) values in μm .



Appendix

Replacing MDS/CC Crucible Carrier

Please read the following chapter to replace the MDS/CC Crucible Carrier.

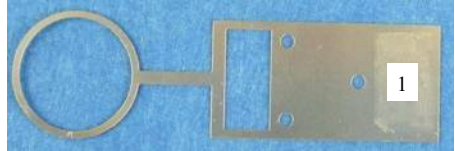

To replace the MDS/CC in the Stage, use a M3 hex key to remove the 6 screws on top of the Stage as indicated by the arrows in the picture opposite.

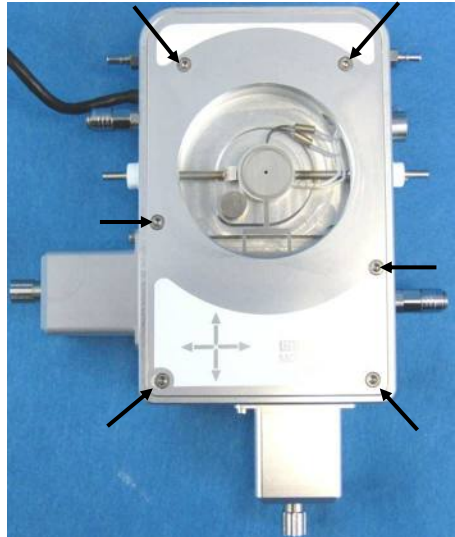

Carefully lift up and remove the Stage Cover (2).

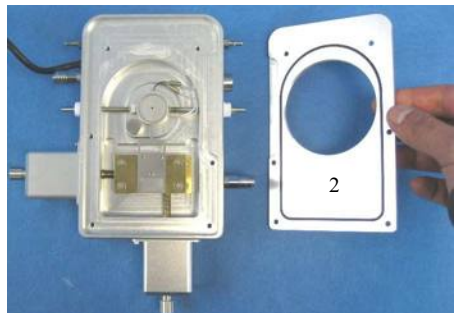

Use a cross head screw driver to remove the 3 screws, indicated by the 3 arrows in the opposite picture and remove the old MDS/CC Sample Holder

Do the reverse to install the new MDS/CC Sample Holder.

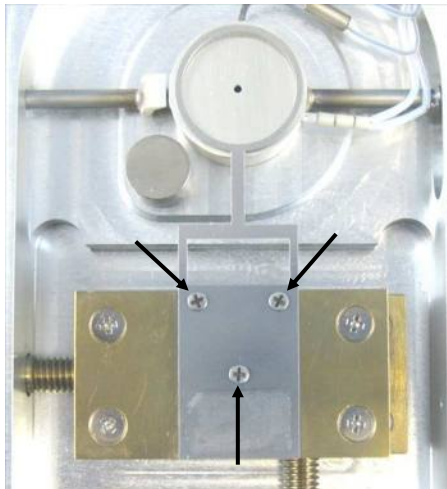

Make sure the new MDS/CC Crucible holder hovers a few millimetres above the silver heating block



G10MT Sample Holder and Sample Mapping

Sample mapping is only possible if you have Linksys32-AV or DV (analogue video or digital video) software and use the Sample Mapping Kit:

G10MT (10mm diameter tapered sample holder)
W10Q (10 x 0.3mm quartz Sample Window)
W9G (9 x 0.17mm glass sample window)

The G10MT Sample Holder (1) has a tapered internal edge (2) to enable the straight edge of the W10Q quartz Sample Window to locate firmly inside the holder during the mapping process

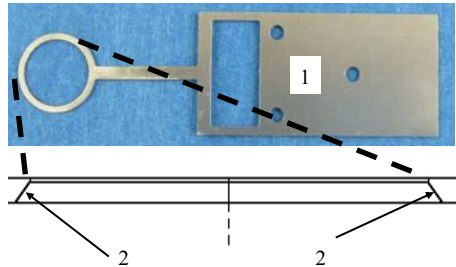

G10MT Sample Holder and Quartz Sample Window

Exchange the G10MT Sample Holder for the G10MT (1) as shown on page 22.

The G10MT Sample Holder is slightly bent at angle to one side. When installed correctly the circular part of the holder should sit flat and press on to the surface of the silver block.

Note: if the holder does not sit flat on the silver block, turn the holder over.

Note: you can use a little force to bend the holder to the correct position if necessary.

In Linksys32 software, Go to the 'MDS Setup' Menu, (page 21) and in the 'Sample area' Menu make sure 'G10' option is selected.

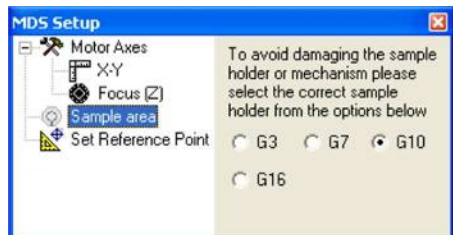

Sample Preparation Using G10MT Sample Holder

Place a W10Q quartz sample window (1) using the vacuum tweezers onto the surface of the silver block next to the end of the sample holder.

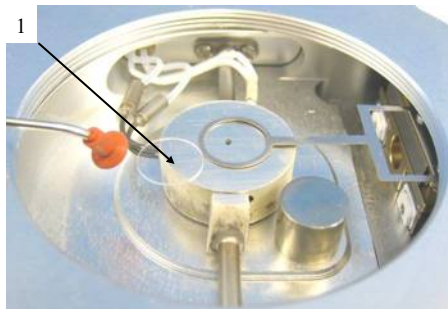

With one hand carefully lift the G10MT about 1mm off the silver heating block and slide the W10Q sample window directly underneath the circular sample holder. Release G10MT and it should clip the sample window into place.



Use Linksys32 software, (page 20) to move the X and Y manipulators by a few millimetres in both directions to make sure the 10mm sample window is fitted securely in place.

Note: you can use the thumbscrews manually to move the X and Y manipulators, but the controller **MUST BE SWITCHED OFF**.

Load the sample onto the top of the sample window.



Ensure that the sample is as small and as flat as heat flow into or out of the sample is affected by the amount of sample area in contact with the temperature controlled sample window.

Place a W9G glass sample window over the sample to create a flat surface for the microscope lens to focus on.

Note: if the sample is a powder, gently tap the top glass cover slip with the back of the vacuum tweezers to disperse powder samples to ensure good thermal contact of irregularly shaped samples and to create a flat surface for the microscope lens to focus on.

Accurate temperatures can be obtained by keeping the sample as small and flat as possible



Sample Mapping Using Linksys32 Software

Please refer to the Linksys32 manual for an overview of the video capture software and how to capture images and setup your camera.

The mapping feature enables the video capture software to build up a mosaic map of the sample by capturing images as the sample holder is moved through viewing area. The final image is a collection of potentially hundreds of individual images. By clicking anywhere on the final image map you can view the image of that particular area, it is similar to zooming in on a portion of an image.

Note: it is very important that the lens has been calibrated correctly and that the correct lens and microscope have been selected in the **'Video Setup'** window. You must also ensure that the camera and stage are setup square and aligned correctly to the microscope. The mapping feature works by the motors moving the sample a fixed distance depending on the calibration made and the lens selected.

To select Mapping right click on the capture control toolbar.

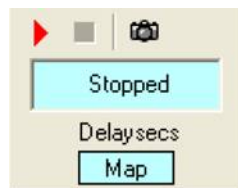

In the **'Capture Setup'** menu select the submenu **'Image mode'** and click on **'Map the sample'**.

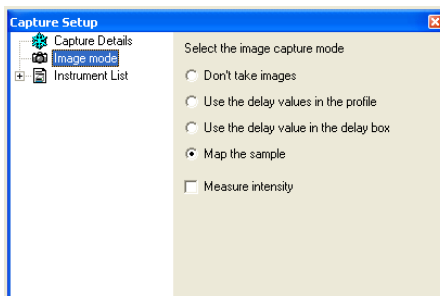

When the Capture Module Record Button (1) has been pressed, a map setup window will ask you to setup the area of the sample to be mapped.

Follow the on screen instructions to set the start and end position of the sample to be mapped.

Start Position

Use the MDS Module joystick control to set the start of the scan area. This will be the top left of the area you wish to start scanning. Press Start Pos.

End Position

Use the MDS Module joystick control to set the end of the scan area then press End Pos.

When you are happy with the Start Position and the End Position, press OK. A map of the scan area will now be built up in the Sample Map window. When the map is finished, or the Capture Module Stop Button has been pressed, the .IML file will be saved as normal, a .MAP file containing the built up map will also be saved with the same name.

Note: press 'Cancel' during setup to exit Map Setup.

The 'Map Error' window message (2) means that the end position was not selected correctly. It must be to the bottom right of the start position.

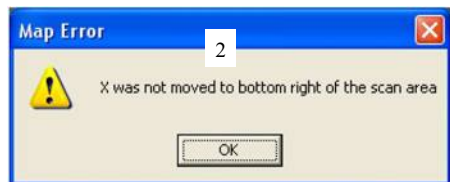
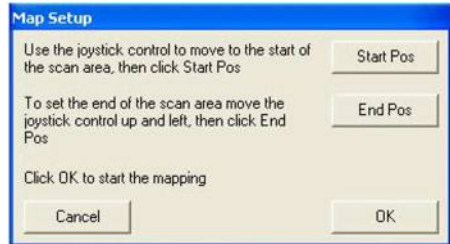

The image below shows a map being created for a fluid inclusion sample. The small image shows what is seen by the microscope and the larger image shows the entire sample in the process of being mapped.

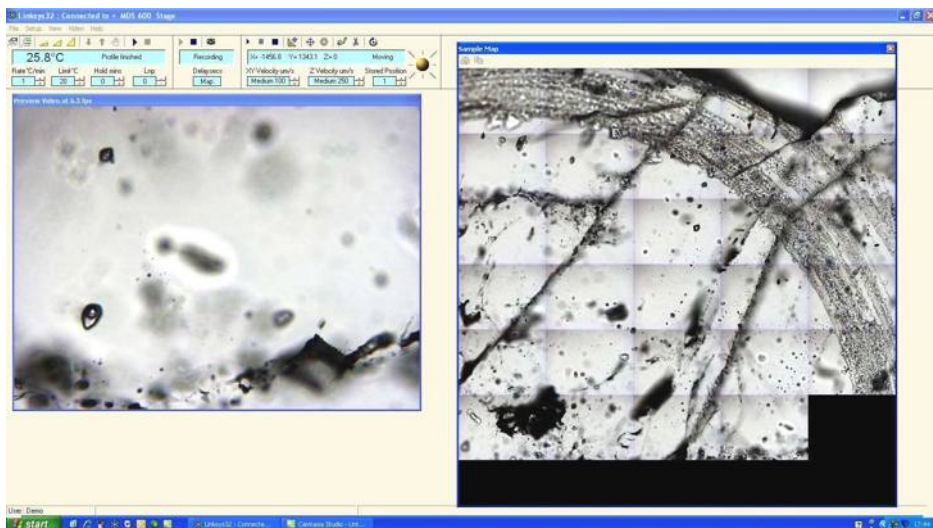

Window Assembly

Lid Window Assembly

To replace the windows in the Stage Lid (1) use the Window Tool (2) and align the two wide spacing pins to the Tube Clip Holder holes and unscrew the Lid Insert (3).

The Stage Lid and Lid Insert should be turned upside down as shown in the diagram opposite and reassembled in the order indicated.

The Lid Insert should be screwed down until the cover slips are held firmly, then turn the assembly over and screw down the Lid Insert until it is felt to come to a stop.

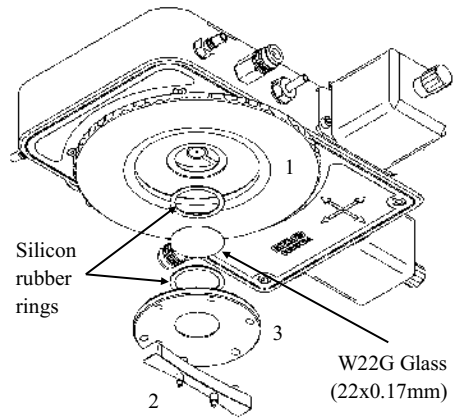

Bottom Window Assembly

Use the 22mm Lock Tool (4) to align it to the two holes of Window Locking Ring (5) and unscrew.

Reassemble the bottom window as shown in the opposite diagram

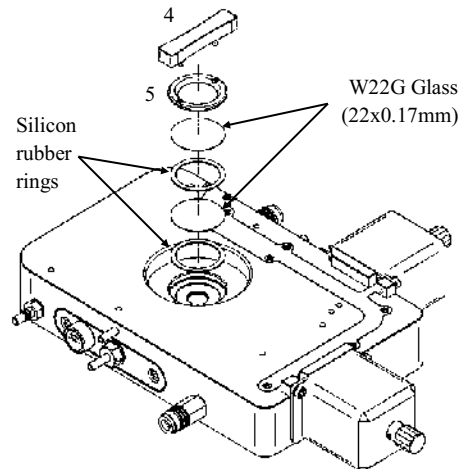

Spares and Accessories

These spares are organised into convenient kits. Purchase a spares kit to avoid downtime with your stage and eliminate future shipping costs.

Part No.	Part Name	Part Description
22222	MDS Kit	Full Replacement Spares Kit
	WGI	Water/Gas Valve Insert x2
	WVC	Water/Gas Valve Connector x2
	SRR	Silicon Rings for Lid and Base (Set of 4)
	TCH	Tube Clip Holder (for Nitrogen de-fogging stage lid tube)
	TCH	Tube Clip Holder (for Nitrogen de-fogging stage lid tube)
	MDS/Q	Quartz crucible for use with MDS/CC
	MDS/CC	Crucible carrier for sample preparation
	LSR	Large stainless steel ring
	W13G	Box of glass sample cover slips for sample preparation 13x0.17mm (x100)
	ACCE	Box of Glass Sample: 22x0.17mm (x50); 16x0.17mm (x50); 22x0.3mm (x10) x2
	WT	Window Tool (for unlocking lid insert)
	LT	22mm Lock ring tool for bottom window
	HEXK	2.5mm Ball Driver Hex Key

Part No.	Part Name	Part Description
22222	MDS Spare Windows Kit	Spare Windows for Lid, Base and samples
	ACCE	Box of Glass Sample: 22x0.17mm (x50); 16x0.17mm (x50); 22x0.3mm (x10) x2
	W13G	13mm diameter glass cover slip for assembly (x100)
	SRR	Silicon Rings for Lid and Base (Set of 4)

Part No.	Part Name	Part Description
0998	ECP	Water Circulator Pump (stage body and window cooling) (220-240V)
0997	ECP	Water Circulator Pump (stage body and window cooling) (110-130V)

Part No.	Part Name	Part Description
22222	G10MT Kit	G10MT Sample Mapping Kit
	G10MT	10mm Sample Holder (tapered)
	W10Q	10mm diameter Quartz Sample Window (0.3mm thick) x2
	W9G	9mm diameter Glass Sample Window (0.17mm thick) Box of 100

Troubleshooting

Cooling fault diagnosis

Ensure that all connections to the stage and Dewar are as described in the specific manual and that the stage lid and top windows are properly sealed.

1. *The cooling rate is less than programmed.*

There can be several causes of this problem, the most likely being that one of the connectors has become blocked or damaged. Check that each tube is fitted tightly to the connector and that none of the tubing is twisted or has come loose. The larger diameter tube leading from the LNP95 consists of a tube within a tube, check that the internal tube is connected, it may have come loose. Any constrictions of either the tubing or the connector will have a drastic effect on the cooling ability of the LNP95. If the connectors and tubing are OK, check that the capillary tubing to the Dewar flask is not bent or damaged and that the filter is intact and unblocked. If any damage has occurred to any of these items then it will be necessary to replace them. If no damage is found, check that the silver block is not constricted. This can be checked, simply by blowing through one of the steel cooling tubes using a compressed air line.

2. *Stage will not cool down to -196°C.*

Check that the stage lid is not touching the silver block when screwed down. Check that the silver block has not been pushed down so that it touches the base of the stage. Check the sample holder ramp is not touching the silver block. Any of these faults will cause a substantial loss of cooling ability.

3. *Condensation and ice forming on the upper side of window*

Realign the window gas tube clip to the required position in the stage lid.

4. *Condensation on the sample and/or the underside of lid window*

This is due to the stage not being sealed properly and therefore allowing moisture in during purging or cooling. Check that the lid and bottom window are sealed correctly and that the silicon seals are in position.

Please visit www.Linkam.co.uk for more FAQ for the stage and instruments.

This page is intentionally blank

This page is intentionally blank

