



Linkam Scientific Instruments

THMS600 / HFS600
Temperature Controlled Stage

USER GUIDE

Contents

Stages Covered by this Manual.....	3
Before Setting Up Your Equipment.....	3
Important Notice.....	4
Warranty.....	4
Equipment Maintenance.....	4
Handling Liquid Nitrogen.....	4
Pressure Warning.....	4
Safety Precautions.....	5
Symbol Reference.....	5
Introduction.....	6
THMS600 Stage Specification.....	6
THMS600 System.....	6
Stage Anatomy.....	7
Stage Assembly.....	7
Lid Assembly.....	7
Mounting Stage to Microscope with Dovetail Substage.....	8
Setting up the Condenser.....	8
Vacuum Tweezers.....	9
Setting up the ECP water circulation pump.....	10
Sample preparation.....	11
THMS/CC Crucible Carrier and Quartz Crucible.....	11
THMS/CC Crucible Carrier and Stainless Steel Ring.....	12
Cooling Connections.....	13
Purging Procedure.....	14
Purging the Stage Method 1.....	14
Purging the Stage Method 2.....	15
Appendix.....	16
Window Assembly.....	16
Lid Window Assembly.....	16
Bottom Window Assembly.....	16
Troubleshooting.....	17
Alternate Configuration: THMS600-PS.....	18
THMS600-PS Stage anatomy.....	19
Connecting pressure tubing.....	20
Alternate Configuration: FTIR600.....	21
FTIR600 Vertical stage.....	22
Alternate Configuration: THMSEL600.....	25
THMSEL600 Stage anatomy.....	26
Ellipsometer window assembly.....	27
Alternate configuration: THMSG600.....	28
THMSG600 Sample preparation.....	29
Alternate configuration: BCS196.....	32
BCS196 Stage anatomy.....	33
BSC196 with Quench Cooling.....	34
Using the Quench Cooling manipulator.....	37
Sample seeding with Seeding Post.....	39
Alternate Configuration: HFS600E-PB4/PB2.....	40
HFS600E-PB4/PB2 Stage Anatomy.....	41
Probe preparation.....	42
Adjusting the Probes.....	44
HFS600 Stage window assembly.....	46
Contact Details.....	48

Stages covered by this manual

The following Linkam stages are covered in this manual:

THMS600 High temperature stage
THMSG600 High temperature geology stage
THMSEL600 High temperature ellipsometry stage
THMS600-PS High temperature pressure stage
THMS600E High temperature electrical stage
HFS600 Basic high temperature stage
HFS600E-PB4/PB2 Basic high temperature stage with electrical probes
FTIR600 High temperature IR stage
FTIRSP600 Vertical high temperature IR stage
BCS196 Biological cryo stage

Before Setting Up Your Equipment

Please register your products by going to the technical support section of our web site www.linkam.co.uk

You will need to register your equipment with us to:

- Activate your warranty and technical support
- Access the online setup videos
- Permanently unlock LINK software (if purchased)

If you have purchased LINK software, or want to try a demonstration of it, please install it first. You will be guided through the LINK software registration process the first time that the software is used, and will need the LINK software registration card to complete this.

Important Notice

Please check that your Linkam equipment has not been damaged during transit. If there is any evidence of external damage DO NOT SWITCH ON ANY ELECTRICAL ITEMS.

Contact LINKAM SCIENTIFIC or their appointed distributor immediately. Your warranty may be impaired if Linkam is not informed of any transport damage within 7 working days of delivery.

NO attempt should be made to repair or modify the equipment in any way, as there are **no user replaceable parts**.

No attempt should be made to open the case except by qualified personnel as hazardous voltages are present.

In order to use this equipment successfully, please take time to read this manual all the way through before using it.

Warranty

This equipment has a warranty against defects in material and workmanship for a period of 12 months. Linkam will either repair or replace products that prove to be defective. For warranty service or repair, this product must be returned to Linkam or a designated service facility.

The warranty shall not apply to defects resulting from interfacing, unauthorized modification or misuse, operation outside of the environmental specifications for the product, or improper site preparation or maintenance.

Technical Support

Any technical questions or queries should be addressed to the Technical Support Department at the address shown on the back of this manual.

Equipment Maintenance

Use a small quantity of isopropyl alcohol with a soft cloth and gently wipe the surface. To clean the hotstage, use isopropyl alcohol (IPA) and cotton swabs. Take great care not to touch the platinum temperature sensor protruding from the side of the heating element. The sensor is very fragile.

Handling Liquid Nitrogen

To cool samples below room temperature a LNP95 liquid nitrogen pump is required. Please refer to your health and safety manual for instructions on how to handle liquid nitrogen safely. Always use in a well ventilated room.

Pressure Warning

The THMS600-PS has been designed specifically for use at 14Bar. Use above this pressure is strictly prohibited and could present a serious health risk. The THMS600-PS is fitted with a pressure release valve (PRV) which will safely vent any excess pressure to atmosphere. A calibration certificate for the PRV is included with your stage. Any tampering or removal of this valve will invalidate your warranty. Should the valve activate, check your gas supply and take steps to avoid over pressuring the system again. Also be aware of the effects of temperature on gas pressure inside the stage; do not rely on the PRV as a means to control the pressure.

The loading of samples and general use of the stage must take place as described in this manual. Always ensure sealing faces are clean and free from any debris. Inspect the lid and base windows prior to use. If there is any sign of damage to the windows or the silicone washers they must be replaced. Spare windows and silicone washers must be purchased from Linkam due to them being a safety critical part. Linkam recommends that when a window or silicone washer has been replaced, the stage is tested before mounting to the microscope to avoid any damage should the window have been replaced incorrectly.

Linkam strongly recommends the THMS600-PS be used on a microscope with a camera system and that suitable shielding is placed around the stage and microscope. It is also advised that users wear suitable personal protective equipment i.e. safety glasses.

- Contact Linkam if any of this manual is unclear before using your stage.
- Contact Linkam if there is any concern with pressurising your stage.
- Refer to your local Health and Safety Regulations for the use of pressurised equipment
- Linkam cannot be held responsible for any personal injury or damage to equipment sustained due to the misuse of your stage.

Safety Precautions

- 1) Read this guide before using the equipment. Save these instructions for later use.
- 2) Follow all warnings and instructions which may be placed on the stage.
- 3) Never use the equipment if any cables have been damaged. Do not allow any heavy objects to rest on the cables. Never lay the cables on the floor.
- 4) Do not obstruct any ventilation holes. Do not attempt to insert anything into these openings. Provide adequate ventilation of at least 75mm all around the equipment.
- 5) Do not expose the equipment to water. If for any reason it gets wet then unplug it from the mains and contact Linkam Scientific Technical Support.
- 6) The equipment is not intended to be used outdoors.
- 7) If any problems occur then turn all Linkam equipment off and contact Linkam Scientific Technical Support.
- 8) Do not remove any covers from the equipment, any servicing should be carried out by qualified service personnel.

Symbol References

Caution:

This safety symbol is on the back panel of the equipment and warns:-



The user must not make or remove any connections while the unit is powered on. To avoid electric shock do not remove the cover. Refer servicing to qualified service personnel.

Caution:



This warning symbol indicates that the surface labelled with this symbol may be hot.

Introduction

Thank you for purchasing the THMS600 Heating and Freezing stage system. Please take the time to read through the manual as it will help you to make the most out of the equipment.

THMS600 Stage Specifications

Maximum temperature:	600°C
Minimum temperature:	-196 °C with LNP95
Maximum heating rate:	150°C/min
Objective Lens WD:	4.5mm
Condenser lens WD:	12.5mm
XY-Manipulators travel:	16mm
Aperture hole:	2mm
Weight:	0.62Kg



THMS 600 System with LNP95

THMS600 System

The system consists of a THMS600 stage, a T95 System Controller and optional LNP95 liquid nitrogen cooling pump.

LINK System control software and digital video capture can be added as an option to control from PC.

The THMS600 stage is mounted onto the microscope by using either specific stage clamps, an adaptor plate or by simply placing on the XY table of the microscope, using double sided adhesive tape.

Stage Anatomy

Stage Assembly

1. Lemo connector for stage lead
2. Heating element carrier assembly
3. Stage body
4. Stage body water connector
5. Gas purge valve
6. Y-Sample manipulator
7. Stage door
8. Door locking thumbscrew
9. X-Sample manipulator
10. Liquid nitrogen cooling connector
11. Bypass stage body water cooling connector
12. Sample chamber
13. Earth safety contact for lid

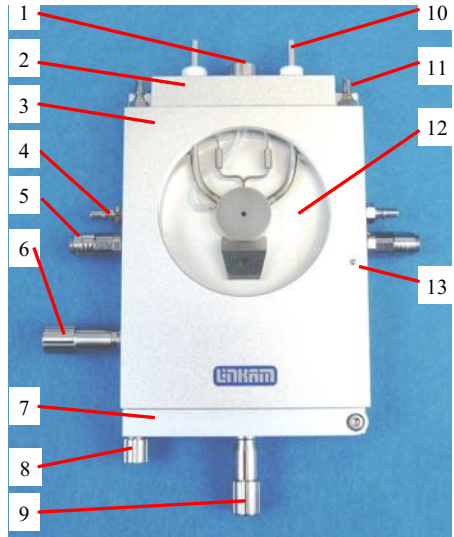

15. Heating element wire
16. Stainless steel cooling tube
17. 22mm diameter pure silver heating block
18. Platinum temperature sensor
19. Sample holder ramp
20. Aperture hole

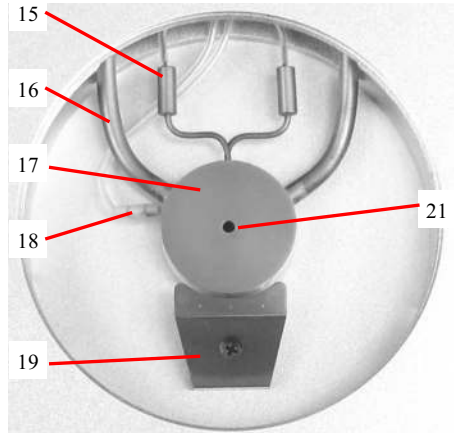

Lid Assembly

The Stage Lid is removed from the stage by unscrewing anti-clockwise.

21. Stage Lid
22. Lid Insert
23. Viewing Window (22mm glass)
24. Holes for Tube Clip Holder or window removal tool

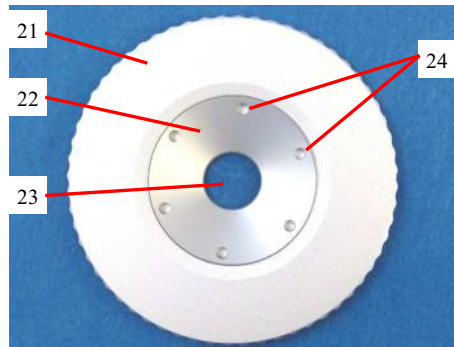

Mounting Stage to Microscope with Dovetail Substage

The following description is for mounting the stage on to microscopes which have a circular dovetail substage assembly (1).

Attach the curved stage clamps (part no. 9542) to the base of the stage using the supplied hex screws and the outer most holes in the base plate.

Adjust the two positioning screws (2) so that approximately 5mm of thread is exposed on the inside edge of the clamp. This will roughly position the stage in the centre of the dovetail.

Place the stage onto the dovetail, then focus a 10X objective lens on the aperture of the silver block. Using the two positioning screws (2) ensure that the aperture is in the centre of the field of view and lock the stage in place by tightening the Locking Thumbscrew (3).

For other types of microscope substage, refer to the diagram included with the stage adaptor.

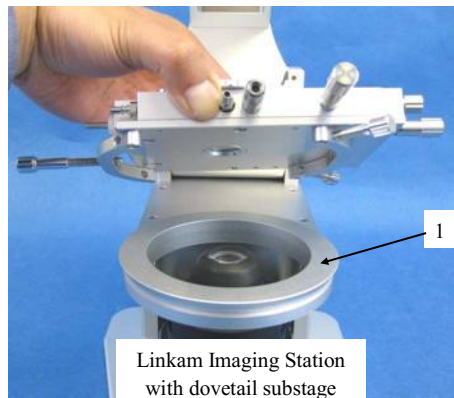
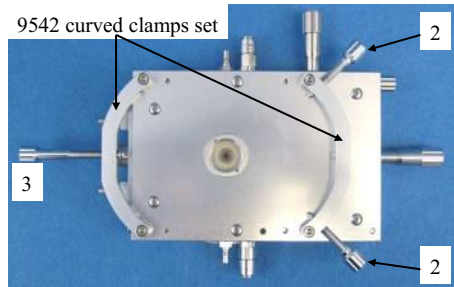

Setting up the Condenser

Place a small sample on a cover slip and place onto the surface of the silver block. Use a 5X or a 10X lens to focus on the sample. Now close down the microscope field diaphragm and adjust the condenser focus so that the edges of the diaphragm are in focus. Now use the condenser positioning screws to centre the condenser in your field of view. Open the diaphragm so that it just fills the field of view.

For more information about Koehler illumination see the extremely informative 'Microscopy Primer' on the Molecular Expressions website.

<http://micro.magnet.fsu.edu/primer/index.html>

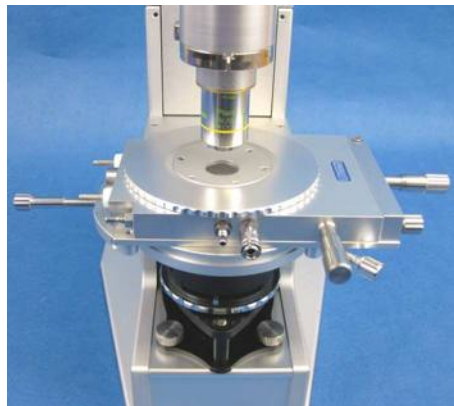

Vacuum Tweezers

The vacuum tweezers are used to manipulate the glass sample slides onto the silver block to prevent fingerprints on the glass and scratching the surface of the silver block when using standard fine tip metal tweezers.

The System is supplied with a Vacuum Tweezers Kit which consists of a Vacuum Pump (1) and tweezers (2).

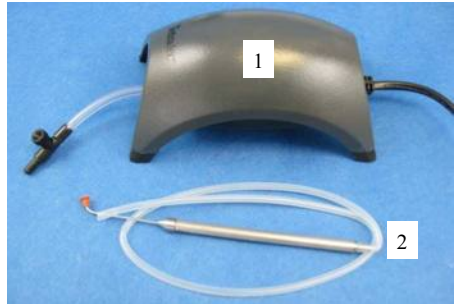

Connect the tubing at the end of the tweezers to the Regulator Valve (3) connection.

Use the dial on the valve to adjust the vacuum for the tweezers.

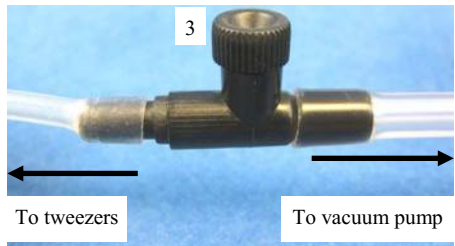

Use a finger to block the hole of the tweezers to pick up a sample cover slip with the suction cup.



Release the finger to drop the sample cover slip.

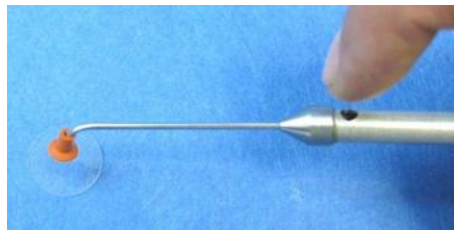

Setting up ECP Water Circulator Pump

If you have purchased the ECP with your system, read the following to set up the ECP with the THMS600 stage. Refer to the ECP manual for more details.



When heating the stage above 300°C for a prolonged period of time, the metal casing body of the stage can get quite hot. Connect the tubing as shown in the opposite picture.

Note: If you have an LNP95 Liquid Nitrogen Cooling system, the tubing from the Dewar must not be connected to the THMS600 stage when heating above 300°C. The thin black capillary tube will melt inside the heater and damage it.

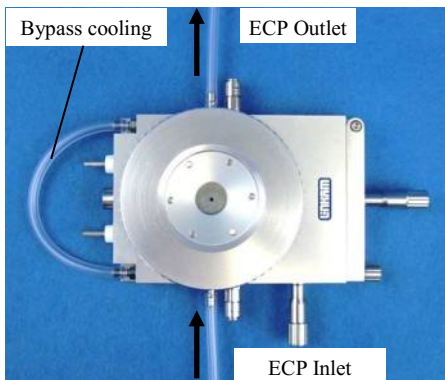

Sample Preparation

The THMS/CC sample holder (1), is either used to load larger volume liquid samples using the THMSQ quartz crucible or to load samples on disposable 16mm glass cover slips.

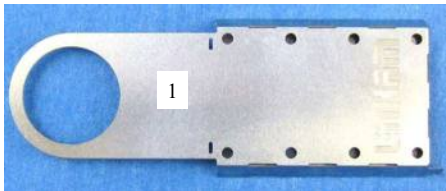

THMS/CC Crucible Carrier and Quartz Crucible

The quartz crucible is useful for loading larger volume liquid samples or when it is preferable to load the sample through the side door without removing the Stage Lid.

Insert the crucible into the THMS/CC sample holder by pushing the crucible into the aperture at the end of the holder.



Load the sample into the quartz crucible. Use as little sample as possible to ensure a small thermal load and therefore better temperature sensitivity.

Microscope objectives require a flat surface to give maximum field of view. Place a 13mm cover slip on top of your sample and gently tap the top with the back of the vacuum tweezers to disperse powder samples or ensure good thermal contact of irregularly shaped samples.

Open the side door of the stage by unscrewing the thumbscrew and carefully push the THMS/CC and crucible into the XY slide mechanism.

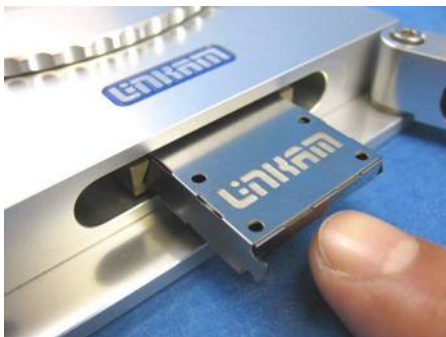

The crucible will be guided to the surface of the silver block by the Sample Holder Ramp. Close the door and tighten the thumbscrew to seal the stage.

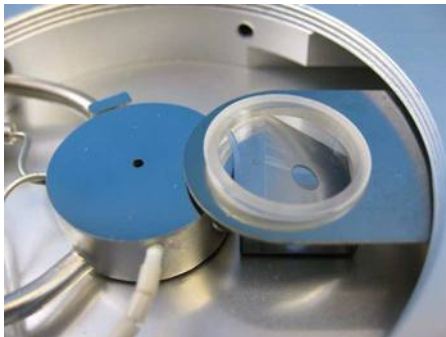

THMS/CC Crucible Carrier and Stainless Steel Ring

This sample loading method is likely to be more routinely used than the quartz crucible as the 16mm sample cover slips can be discarded after each experiment.

Insert the THMS/CC into the stage as described in the previous section .

The THMS/CC should not make contact with the surface of the silver block and should be suspended a few millimetres above it.

Place the Stainless Steel Ring (1) within the THMS/CC.

Tap the edge of the ring lightly to ensure that it has dropped through the aperture of the THMS/CC and sits properly on the surface of the silver block.

It is critical that the ring is able to move freely inside the aperture of the sample holder and sit flat against the surface of the silver block.

Use the vacuum tweezers or a pair of tweezers as shown and place a 16mm glass cover slip (2) into the stainless steel ring. Tap the edges lightly to ensure that it sits flat against the surface of the block. If the cover slip does not sit perfectly flat against the temperature controlled surface the heat flow will be compromised and the sample temperature will be significantly different to the displayed temperature. The Stainless Steel Ring is used to push the 16mm cover slip around the surface of the block when using the XY manipulators.

Using a pipette or tweezers place the sample on the 16mm cover slip. Ensure that the sample is as small as possible and that it is as flat as possible. Heat flow into or out of the sample is affected by the amount of sample area in contact with the temperature controlled cover slip. Place a second 16mm cover slip on top of the sample to create a flat surface for the microscope lens to focus on.

Accurate temperatures can be obtained by keeping the sample as small and flat as possible.

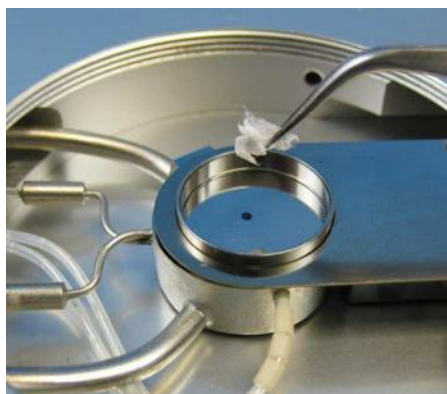
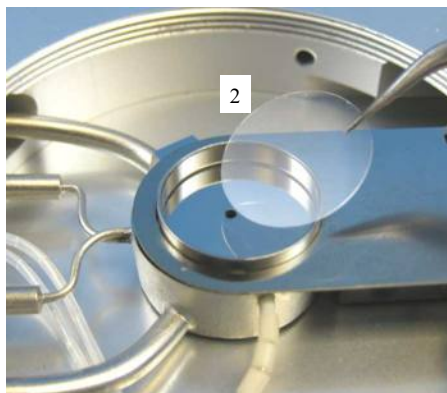
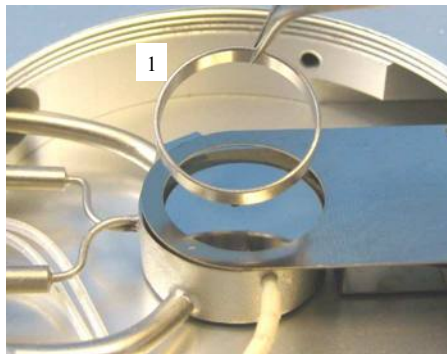

Cooling Connections

These connections need only be made if the experiments are to be carried out below room temperature.

The Dewar siphon (1) is the thick white foam tubing and is attached to the liquid nitrogen Dewar. The thin black capillary tube inside the white foam tube must be inserted into the liquid nitrogen cooling connectors on the stage.

The white tubing slides on to the outside of the connector. Twist the siphon whilst sliding it on and push until it comes to a stop. It does not need to go all the way to the base of the connector.

The thicker silicon tube from the LNP95 cooling pump ends in a white PTFE connector (2), this is pushed over the end of the other stainless steel connector as seen in the image.

The short tube branching from the side of this white connector is the Gas Purging Tube (3). There is a valve opening Insert connector (4) inserted into the end of this tube. During the purging procedure, insert this connector into the Gas Purge Valve (5) on the side of the stage to open it.

The Gas Purge Valve (5) is opened when the Gas Insert (6) is pushed firmly into the connector, a “click” is heard when the two parts are connected properly. To remove the Gas Insert, push the outer sleeve of Gas Purge Valve toward the stage and the Gas Insert (6) should drop out.

There is a second Gas Purge Valve on the opposite side of the stage to allow the gas to leave the stage. A Gas Insert must also be inserted into this Gas Purge Valve (7) when purging.

The smaller tube from the outlet on the LNP95 should be placed in position on the top of the lid using the Tube Clip Holder (8). This tube blows warm recycled nitrogen gas across the lid window to prevent condensation on the viewing window surface.

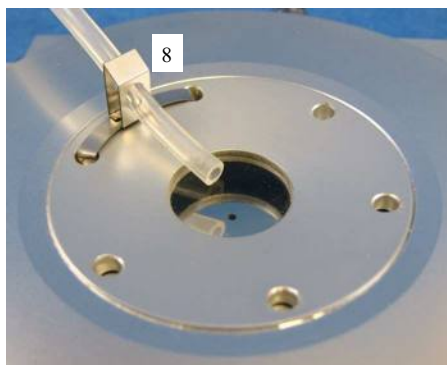
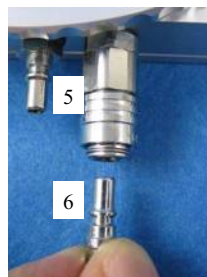
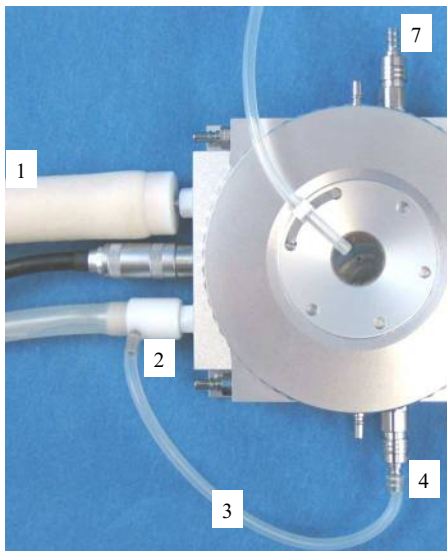

Purging the Stage Method 1

There are two methods for purging the stage. Method 1 uses recycled nitrogen gas produced by the LNP95 from the 2L Dewar.

1. Make sure the stage lid is in place and the stage door is closed.
2. Switch on the temperature programmer and set the limit to 40°C. Press the START button and wait until the temperature limit is reached. Press HOLD to hold the temperature at 40°C.
3. Switch on the LNP95 cooling system and set it to manual mode, (see page 13) and set the speed to maximum of 100.
4. Check that the Gas Inserts are locked into place
5. Using a finger on the left hand, block the hole in the white plastic pump connector found on the perpendicular side to the purging tube. Still working with the left hand, pinch the narrow window tube to block it. This action will divert all of the nitrogen gas to the Purging Tube and through the Stage Chamber.
6. With the nitrogen gas flowing through the Sample Chamber, use a finger on the right hand to block the gas outlet for a few seconds to allow pressure build, then release the gas. Repeat this for a few minutes to purge the stage.
7. Look at the change of reflection in the stage window as the stage is pressurised and released to check that the stage is properly sealed. If there is no change, there may be a leak due to incorrect placing of the silicon o-rings in either the bottom or lid window or the window (top/bottom may be broken).
8. The purging procedure allows mixing of nitrogen gas with the residual air inside the Sample Chamber. By pressurising the chamber with nitrogen gas and releasing it, the air inside the Chamber is being diluted with the nitrogen gas.
9. Remove the two Gas Inserts and unblock the pump connector and window tube.
10. Change the LNP95 to **AUTOMATIC** mode so that the T95 automatically controls pump speed during your cooling experiment
11. Go to www.linkam.co.uk and register your equipment to see videos of how to purge and more.

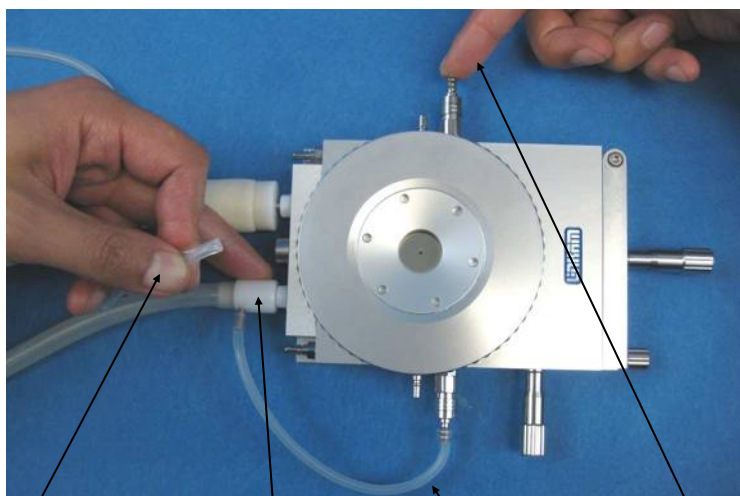

Pinch window tube
with left hand

Block hole in
Connector with finger
pump connector

Purging
tube

Block and release outlet
valve with finger

Purging the Stage Method 2

This method uses an inert gas from a gas cylinder to purge the stage at temperatures above ambient when the LNP95 is not required.

1. Make sure the Stage Lid is in place and the Stage Door is closed.
2. From a gas cylinder connect the Gas Insert with a tubing 3mm inner diameter and 6mm outer diameter to the Gas Purge Valve (1).
3. Connect a Gas Insert to the opposite side Gas Purge Valve (2).
4. Use the gas regulator to set a gas flow rate of 1.5L/min.
5. With the gas flowing through the Sample Chamber, block the gas outlet for a few seconds and releasing the gas outlet valve with a finger. Repeat this for a few minutes to purge the stage.

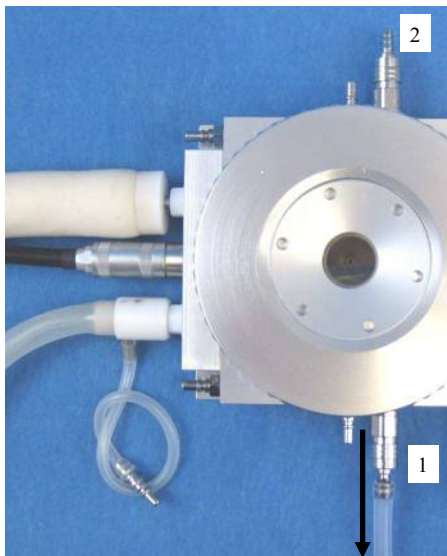

To gas cylinder

Reduce the gas flow rate to 20cc/min to continuously purge the stage or remove the two Gas Inserts to keep the chamber under closed inert atmosphere.

Note: Helium gas is not recommended for continuous purging. This gas has a very high thermal conductivity and will cool the silver heating block too much during an experiment and may cause the temperature to fluctuate.

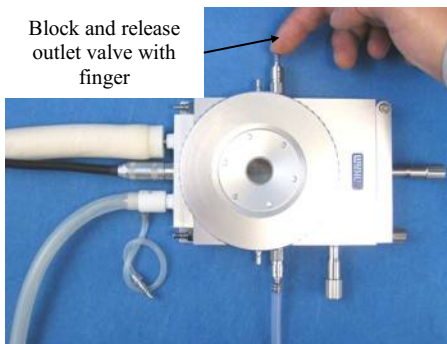

Appendix

Window Assembly

Lid Window Assembly

To replace the windows in the Stage Lid (1) use the Window Tool (2) and align the two wide spacing pins to the Tube Clip Holder holes and unscrew the Lid Insert (3).

The Stage Lid and Lid Insert should be turned upside down as shown in the diagram opposite and reassembled in the order indicated.

The Lid Insert should be screwed down until the cover slips are held firmly, then turn the assembly over and screw down the Lid Insert until it is felt to come to a stop.

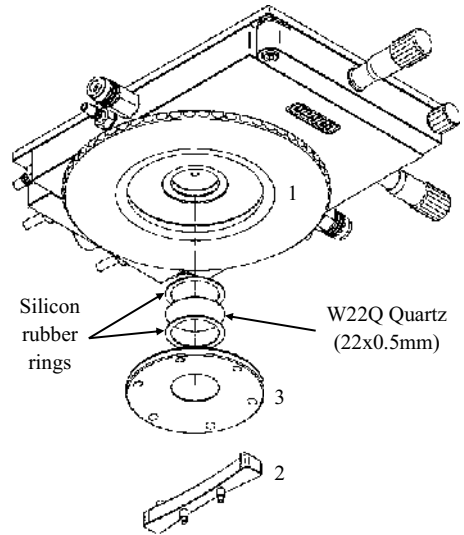

Bottom Window Assembly

Use two narrow spacing pins of Window Tool (2) to align it to the two holes of Window Locking Ring (4) and unscrew.

Reassemble the bottom window as shown in the opposite diagram

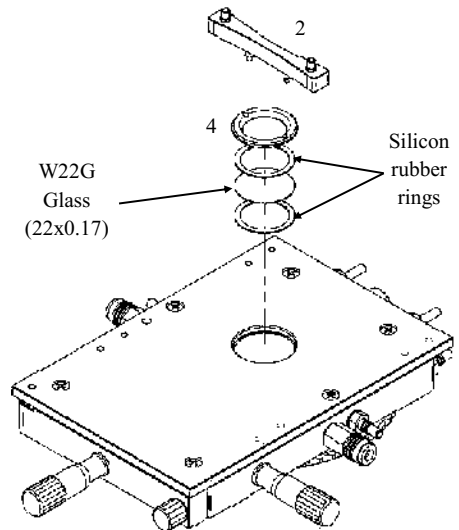

Troubleshooting

Cooling fault diagnosis

Ensure that all connections to the stage and Dewar are as described in the specific manual and that the stage lid and top windows are properly sealed.

1. *The cooling rate is less than programmed.*

There can be several causes of this problem, the most likely being that one of the connectors has become blocked or damaged. Check that each tube is fitted tightly to the connector and that none of the tubing is twisted or has come loose. The larger diameter tube leading from the LNP95 consists of a tube within a tube, check that the internal tube is connected, it may have come loose. Any constrictions of either the tubing or the connector will have a drastic effect on the cooling ability of the LNP95. If the connectors and tubing are OK, check that the capillary tubing to the Dewar flask is not bent or damaged and that the filter is intact and unblocked. If any damage has occurred to any of these items then it will be necessary to replace them. If no damage is found, check that the silver block is not constricted. This can be checked, simply by blowing through one of the steel cooling tubes using a compressed air line.

2. *Stage will not cool down to -196°C.*

Check that the stage lid is not touching the silver block when screwed down. Check that the silver block has not been pushed down so that it touches the base of the stage. Check the sample holder ramp is not touching the silver block. Any of these faults will cause a substantial loss of cooling ability.

3. *Condensation and ice forming on the upper side of window*

Realign the window gas tube clip to the required position in the stage lid.

4. *Condensation on the sample and/or the underside of lid window*

This is due to the stage not being sealed properly and therefore allowing moisture in during purging or cooling. Check that the lid and bottom window are sealed correctly and that the silicon seals are in position.

Please visit www.Linkam.co.uk for more FAQ for the stage and instruments.

Alternate Configuration: THMS600-PS

Thank you for purchasing the THMS600-PS Temperature Controlled Pressure System. Please take the time to read through the manual as it will help you to make the most out of the equipment. The stage and its accessories are packed in the protective hard plastic case. It's recommended that you use this case to store the stage when it is not in use for a long period of time

The THMS600-PS has specifically been designed for use at 14bar. When in use, **the stage must not be taken above this pressure**. There is a safety pressure valve that releases gas pressure above 14bar. At 14bar of pressure the stage temperature range is: -100°C to 500°C

The THMS600-PS is designed for use with pressurised air. For use with other gases, please contact support@linkam.co.uk

THMS600-PS Stage Specifications

Maximum temp at atmospheric:	600 °C
Minimum temp at atmospheric:	-196°C
Maximum pressure:	14 bar
Maximum Temperature at 14Bar:	500°C
Minimum Temperature at 14Bar (with LNP95 System):	-100°C
Maximum Heating Rate:	150°C/min
Maximum Cooling Rate:	30°C/min
Aperture hole size:	1.3mm
Stage Body Dimensions:	160x80x24mm
Weight:	1.2Kg
Objective Lens WD:	8.3mm
Condenser Lens WD:	14.5mm

THMS600-PS Pressure Systems

THMS600-PS Pressure System:
The system consists of a THMS600-PS stage, and a T95-LinkPad System Controller.

Low Temperature THMS600-PS System:
The System has an additional LNP95 Liquid Nitrogen Cooling Pump System and LINK Temperature control software.

The stage is mounted onto the microscope by using specific stage clamps or an adaptor plate.

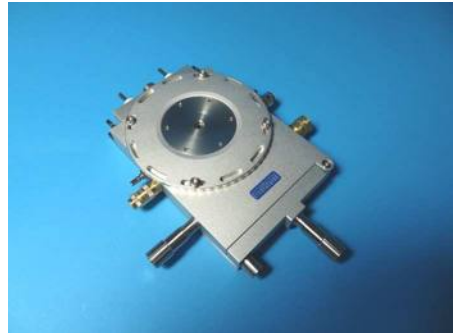

THMS600-PS Stage Anatomy

Stage Assembly

1. Lemo connector for Stage Connection Lead
2. Heating element carrier assembly
3. Platinum temperature sensor
4. 25mm Diameter pure silver heating / cooling block
5. Stage body water cooling connector
6. Purge Valve
7. X-Sample manipulator
8. Side door locking thumbscrew
9. Y-Sample manipulator
10. Liquid nitrogen cooling connector
11. Stage body water cooling bypass loop connector
12. Stainless steel liquid nitrogen cooling tube
13. Pressurised gas inlet (push-to-fit)
14. Sample holder ramp
15. Safety pressure release valve

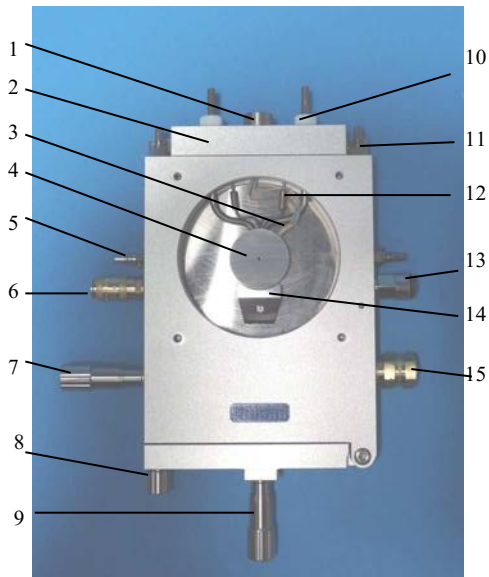

Lid Assembly

16. Stage lid
17. Lid insert
18. 2mm thick Quartz window
19. Tube Clip Holder and tubing for nitrogen defogging stage window.

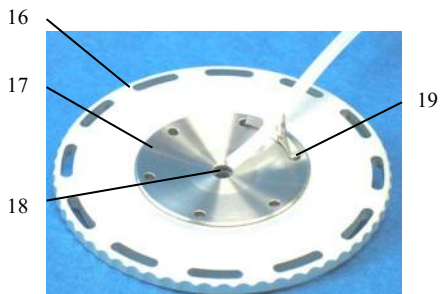

Connecting Pressure Tubing

The THMS600-PS Stage has a Safety Pressure Release Valve (1). The safety pressure release valve will automatically vent excess pressure above the rated stage pressure.

Note: **Do not tamper with the Safety Pressure Release Valve or adjust it in anyway.** This will compromise safety and also invalidate the warranty

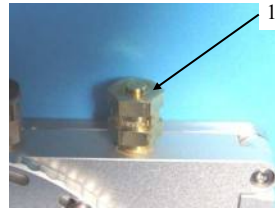

The supplied flexible nylon pressure tubing (6mm outer diameter; 3mm inner diameter) is connected to the pressurised gas inlet with a push-to-fit connection.

Make sure the end 10mm of the tubing is free of dirt, grease and has no indentations, scuffs or defects. Cut the end off with a sharp knife if need be.

Line up the pressure tubing with the pressurised gas inlet and push firmly to fix the tubing in place.

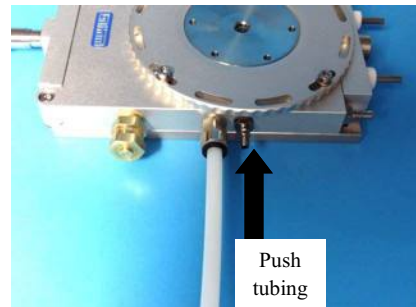

Note: to remove the tubing, hold and pull back the black locking ring toward the body of the stage and pull the tubing free of the pressurised gas inlet.

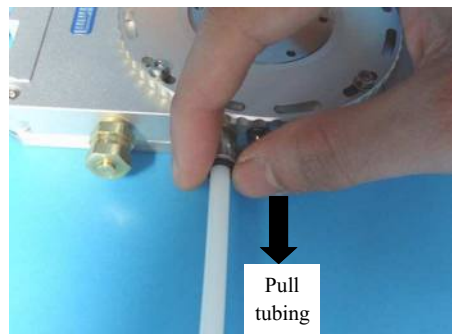

Alternate Configuration: FTIR600

Thank you for purchasing the FTIR600 Stage system. Please take the time to read through the manual as it will help you to make the most out of the equipment.

FTIR600 Stage Specifications

Maximum temperature:	600°C
Minimum temperature:	-196 °C with LNP95
Maximum heating rate:	150°C/min
Objective light approach angle:	116°
Objective Lens WD:	4.5mm
Condenser lens WD:	12.5mm
XY-Manipulators travel:	16mm
Aperture hole:	3mm or 1.3mm
Weight:	0.6Kg



FTIR600 Stage System with LNP95

FTIR600 System

The system consists of a FTIR600 stage, a T95-LinkPad System Controller and optional LNP95 liquid nitrogen cooling pump.

LINK System control software and digital video capture can be added as an option to control from a PC.

There are 2 FTIR600 Stages available:

1. The FTIR600 stage is used horizontally and mounted onto an upright microscope by using either specific stage clamps, an adaptor plate or by simply placing on the XY table of the microscope, using double sided adhesive tape.
2. The FTIR600 Vertical Stage is supplied with a Base Stand and is designed to work vertically inside a FTIR Spectrometer..

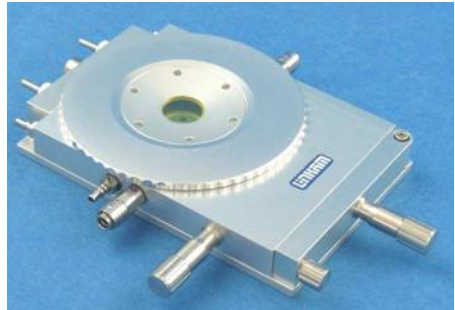

FTIR600 Stage



FTIR600 Vertical Stage

FTIR600 Vertical Stage

Only read the following section if you have purchased the FTIR600 Vertical Stage. This chapter will provide additional information for you to set up and use this stage.

The stage is designed to stand vertically and fit inside your spectrometer. The vertical sample holder is used to keep the sample in place.

The FTIR600 Vertical Stage has the same specifications and works in exactly the same way as the standard FTIR600. The heater assembly is located on the side, the Gas Purge Valve and Stage body water cooling connectors are repositioned so that an additional Base Stand can be included in the Stage design to make the stage stand in a vertical position.

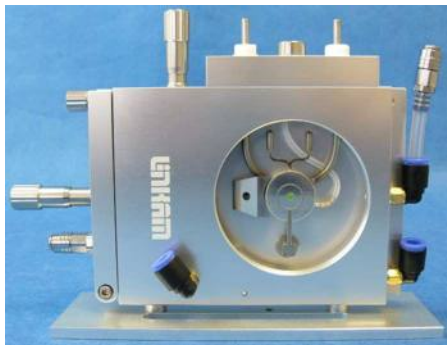

Check the dimensions (mm) of the Stage in the diagram below to align the IR beam to the stage's central aperture hole.

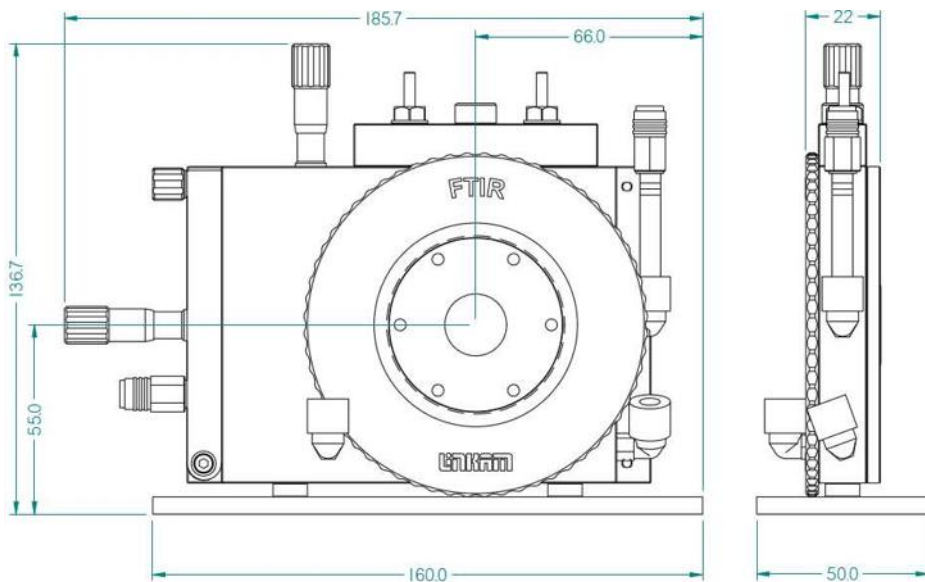

FTIR600 Vertical Stage Assembly

The FTIR600 Vertical Stage has the same specifications and works in exactly the same way as the standard FTIR600. The heater assembly is located on the side, the Gas Purge Valve and Stage body water cooling connectors are repositioned so that an additional Base Stand can be included in the Stage design to make the stage stand in a vertical position.

1. Heating element carrier assembly
2. Gas purge valve with Tubing
3. Gas Purge Valve
4. Base Stand Assembly
5. Stage body water connector
6. Vertical Sample Holder Assembly (Post and Holder)

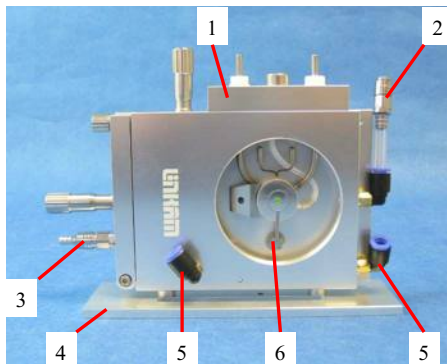

Base Stand Assembly

Fix the Stand Assembly to the Stage using the two screws (1) to the two holes (2) on the bottom of the Stage as shown in the opposite diagram.

Note: Make sure the two spacers (3) are placed between the Base Stand (4) and the Stage.

Note: make sure the Base Stand is in the correct orientation as seen in the opposite diagram.

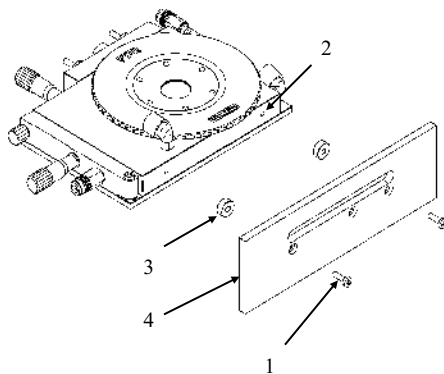

FTIR600 Vertical Stage Setup

Gas Purge Valve with Tubing Connection

The Stage is sent out with Gas Purge Valve with Tubing (1) disconnected.

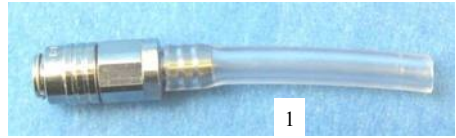

To connect the Gas Purge Valve with Tubing, use one hand to hold the black and blue colour gas valve (2), then firmly and push the tubing into the hole as far it can go.

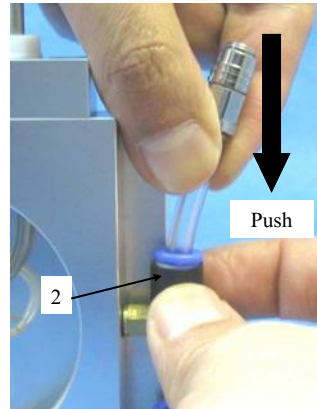

Note: to remove the Gas Purge Valve with Tubing, pull back and hold the blue O-ring (3) and at the same time pull on the Gas Purge Valve with Tubing.

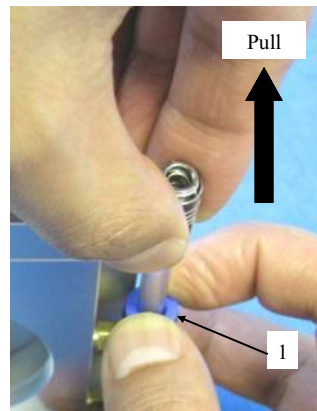

Alternate Configuration: THMSEL600

Thank you for purchasing the THMSEL600 Stage. Please take the time to read through the manual as it will help you to get the most out of the equipment.

THMSEL600 Stage Specifications

Minimum temperature: ambient
Maximum temperature: 600°C
Maximum heating rate: 150°C/min

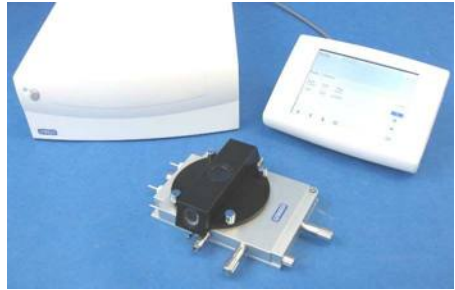

Ellipsometer High
Temperature System

Objective light approach angle
for Ellipsometer side windows: 140° overall

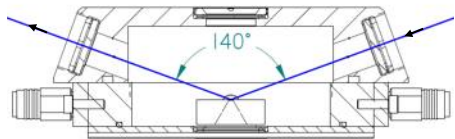

THMSEL600 System

The system consists of a Ellipsometer High Temperature Stage and T95-LinkPad System Controller.

LINK System control software and digital video capture can be added as an option to control from PC.

The top and bottom windows have 22mm glass windows fitted. For the side windows of the Ellipsometer lid there is a choice of quartz or ZnSe windows as ordered with the stage.

Quartz 18mm x 5.0mm thick (spectroscopy grade)

Quartz 18mm x 2.0mm thick

Quartz 18mm x 0.5mm thick

ZnSe 18mm x 2.0mm thick

THMSEL600 Stage Anatomy

Stage Assembly

1. Lemo connector for Stage Connection Lead
2. Heating element carrier assembly
3. Platinum temperature sensor
4. 22mm Diameter silver block
5. Sample chamber
6. X-Sample manipulator
7. Door locking thumbscrew
8. Stage body water connector
9. Heating element wire
10. Stainless steel tube
11. Stage body water connector
12. Gas purge valve
13. Sample holder ramp
14. Stage door
13. Y-Sample manipulator

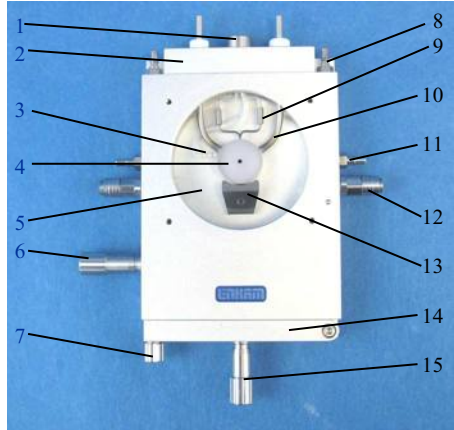

Lid Assembly

The Lid (15) is removed from the stage by unscrewing the 4x Clamp Screw (14) on top of the lid

14. Clamp Screw
15. Ellipsometer Stage Lid
16. 22mm Window
17. 18mm Window

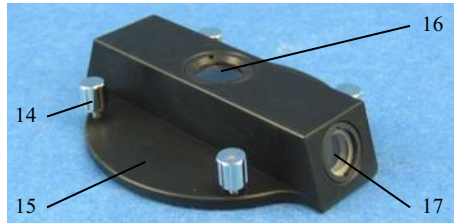

Ellipsometer Windows Assembly

If the windows need to be replaced they should be disassembled as shown in the diagram.

Top Window Assembly

Use the Window Tool (1) to remove the 22mm Locking Ring (2) and reassemble the Top Window as shown in the diagram.

1. Window Tool (1)
2. Locking Ring (22mm)
3. Silicon Rubber Ring (22 x 18mm)
4. Glass Window (22 x 0.17mm)

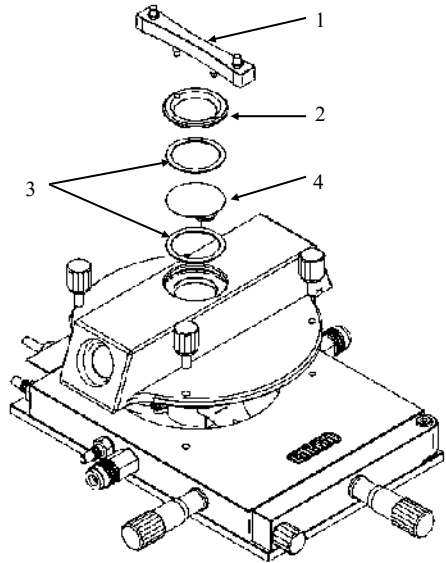

Side Windows Assembly

Use the Side Window Locking Tool (5) to remove the Side Window Locking Ring (6) and reassemble the Side Window as shown in the diagram.

5. Side Window Locking Tool
6. Side Window Locking Ring
7. Silicon Rubber Ring (17 x 12mm)
8. Side Window (up to 5mm thick)

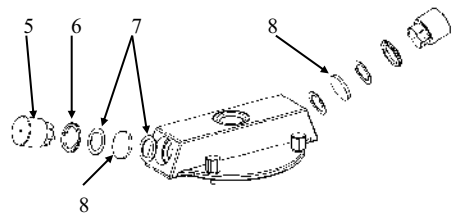

Bottom Window Assembly

Use the Window Tool (1) to remove the 22mm Locking Ring (2) and reassemble the Bottom Window as shown in the diagram.

1. Window Tool (1)
2. Locking Ring (22mm)
3. Silicon Rubber Ring (22 x 18mm)
9. Glass Window (22 x 0.3mm)

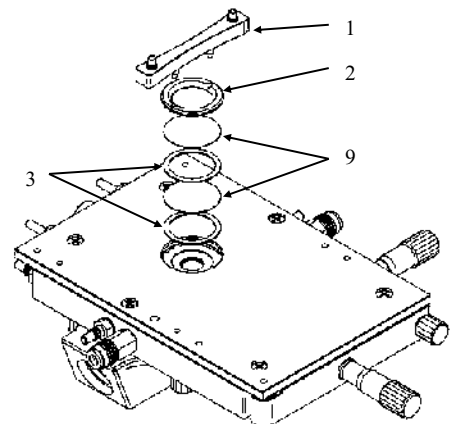

Alternate Configuration: THMSG600

Thank you for purchasing the THMSG600 temperature controlled geology system. Please take the time to read through the manual as it will help you to make the most out of the equipment.

THMSG600 Stage Specifications

Maximum temperature: 600°C
Minimum temperature: -196 °C with LNP95
Maximum heating rate: 150°C/min
Objective Lens WD: 4.5mm
Condenser lens WD: 12.5mm
XY-Manipulators travel: 16mm
Aperture hole: 1.3mm
Weight: 0.62Kg



THMSG600 System

The system consists of a THMSG600 stage, a T95-LinkPad System Controller and LNP95 liquid nitrogen cooling pump system.

LINK System control software and digital video capture can be added as an option to control from PC. If the LINK is supplied with the system please install the software first and activate the licence key. See the LINK manual for more information

The THMSG600 stage is mounted onto the microscope by using either specific stage clamps, an adaptor plate or by simply placing on the XY table of the microscope, using double sided adhesive tape.

THMSG600 Sample Preparation

When working with fluid inclusions both the optical performance and the temperature performance becomes critical. It is very important to avoid using too many glass cover slips as each layer affects the sharpness of the image seen by the microscope.

For accurate results it is most important that the surface of the block, window and carrier are extremely clean, since air gaps between the silver block and the sample window will result in temperature errors.

The block is made of silver and since it is a soft metal it can get scratched easily especially by using sharp fine tweezers. This can cause a ridge to form which prevents the sample window from sitting flat on the block with the resulting air gap causing significant temperature errors.

For this reason we recommend that the sample and windows are always handled using the Linkam Vacuum Tweezers.

G7T Sample Holder with Silver Lid

The G7T (1) has a tapered internal edge (2) to enable the straight edge of the 7mm sapphire or quartz window to locate correctly inside the holder.

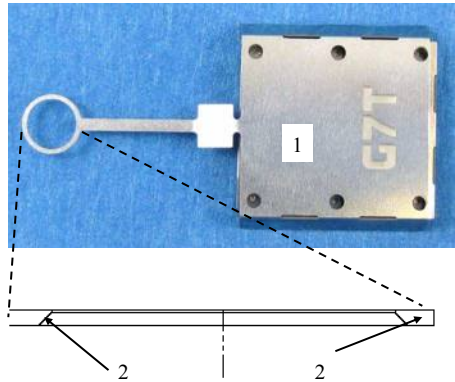

To load the sample holder open the side door of the stage and slide the G7T in. Push the sample holder as far as it will go then gently push the door shut and lock the door in place with the thumb screw.



The circular end of the sample holder will go up the Sample Holder Ramp (1) ramp and rest on surface of the silver block.

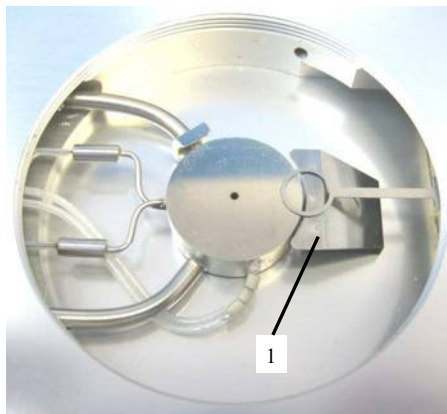

Place a 7mm W7S sapphire or a W7Q quartz window (2) using the vacuum tweezers onto the surface of the silver block next to the end of the sample holder.

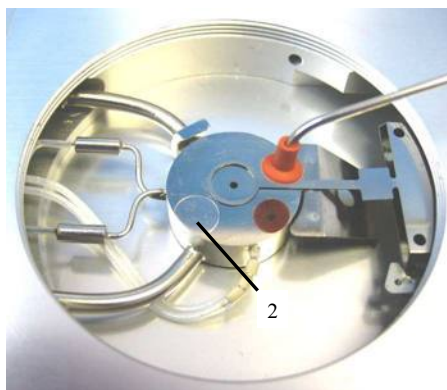

With one hand carefully lift the G7T about 1mm off the silver heating block and slide the 7mm sample window directly underneath the circular sample holder. Release G7T and it should clip the sample window into place.



Adjust the XY-manipulators by a few turns in both directions to make sure the 7mm sample window is fitted securely in place.

Now load the sample onto the top of the sample window.

Place the Silver Cover Lid (SCO) on top of the silver heating block as shown in the opposite picture. Make sure the gap in the SCO (1) is aligned with the stem (2) of the Sample holder.

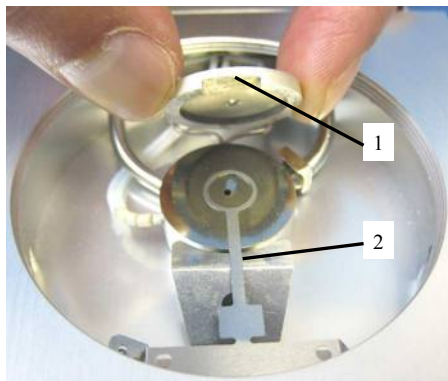

The gap in the SCO allows movement of the Sample Holder when the XY manipulators are used.

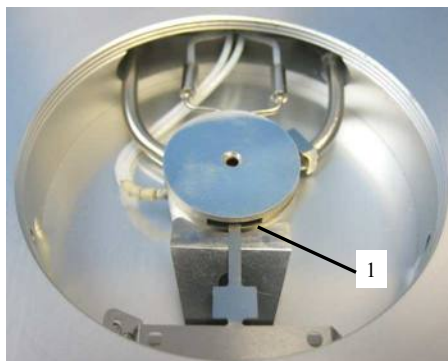

To improve temperature stability an optional 13mm glass window (W13G) (3) can be used to cover the aperture hole of the SCO.

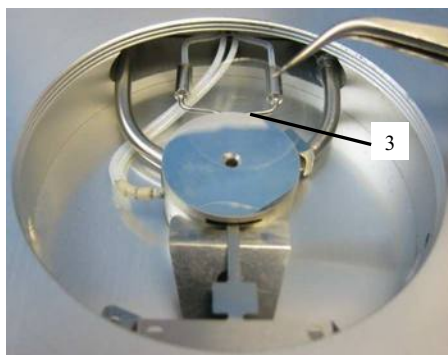

Alternate Configuration: BCS196

Thank you for purchasing the BCS196 Biological Cryo-Stage System. Please take the time to read through the manual as it will help you to make the most out of the equipment.

BCS196 Stage Specifications

Minimum temperature: -196 °C
Maximum temperature: 125°C
Maximum heating rate: 150°C/min
Objective Lens WD: 4.5mm
Condenser lens WD: 12.5mm
XY-Manipulators travel: 16mm
Aperture hole: 1.3mm
Weight: 0.62Kg



BCS196 System

This Cryostage System consists of the BCS196 cryostage, a T95-LinkPad System Controller and LNP95 liquid nitrogen cooling pump as standard (as seen above).

LINK System control software and digital video capture can be added as an option to control from PC.

The BCS196 Cryo-Stage is mounted onto the microscope by using either specific stage clamps, an adaptor plate or by simply placing on the XY table of the microscope, using double sided adhesive tape.

BCS196 Stage Anatomy

Stage Assembly

1. Lemo connector for stage lead
2. Heating element carrier assembly
3. Stage body
4. Stage body water connector
5. Gas purge valve
6. Y-Sample manipulator
7. Stage door
8. Door locking thumbscrew
9. X-Sample manipulator
10. Liquid nitrogen cooling connector
11. Bypass stage body water cooling connector
12. Sample chamber
13. Earth safety contact for lid
14. Hinge for stage door

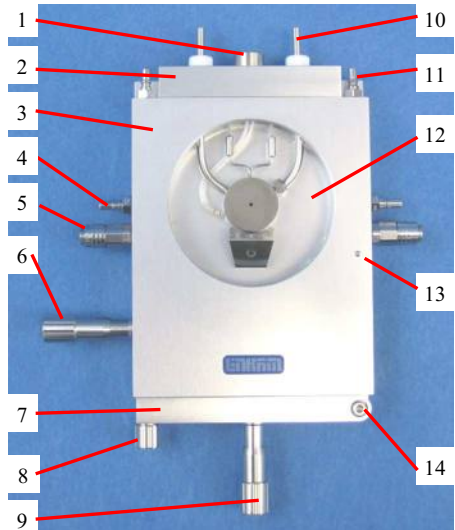

15. Heating element wire
16. Stainless steel cooling tube
17. 22mm diameter pure silver heating block
18. Platinum temperature sensor
19. Sample holder ramp
20. Seeding post
21. Aperture hole

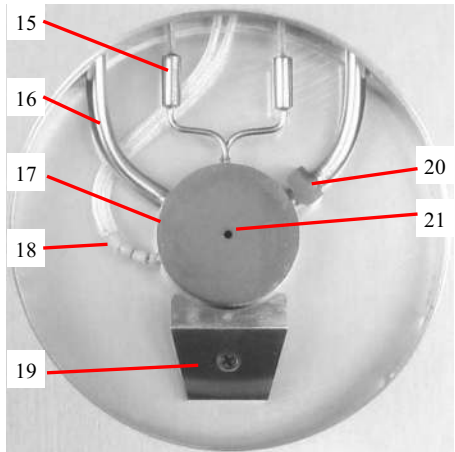

Lid Assembly

The Stage Lid is removed from the stage by unscrewing anti-clockwise.

22. Stage Lid
23. Lid Insert
24. Viewing window (22mm glass)
25. Holes for Tube Clip Holder or window removal tool

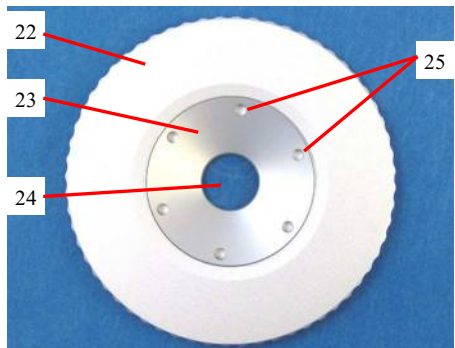

BCS196 with Quench Cooling Option

This option is for high speed vitrification cooling.

When the BCS196 Stage is ordered with the Quench Cooling Option, it is supplied with the following sample slides:

- QSM G7T Sample Holder
- QSM G16 Sample Holder
- QSM G17.5 Sample Holder



To convert a standard BCS196 with this option, it must be returned to Linkam for modifications to suit the following:

1. Warm transfer post
2. Quench Cooling Transfer Manipulator
3. QSM G7T Sample holder (supplied with W7S)
4. QSM G17.5 Sample Holder
5. QSM G16 Sample Holder

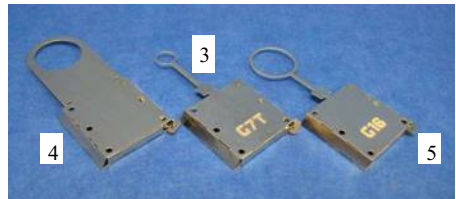

The G7T (3) has a tapered internal edge to enable the straight edge of the 7mm sapphire window to locate correctly inside the holder.

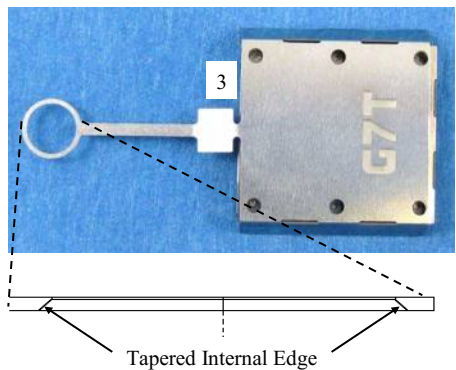

BCS196 with Quench Cooling Option.

Sample Holder Troubleshooting:

It is possible that the retaining catch of the sample holder may disengage if excessive force is used.

1. Use a set of fine tweezers to grip the retaining catch.
2. Pull the retaining catch out from the sample holder.
3. Relocate the retaining catch within locating slot (also shown on page 16).



Problem - The retaining catch has disengaged and is resting within the sample holder.

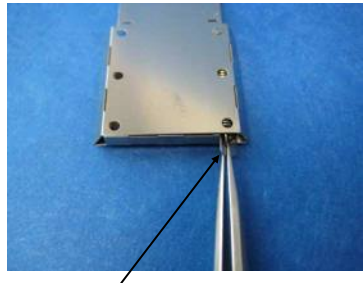

Solution - 1. Grip the retaining catch with tweezers.
2. Pull the retaining catch out from the sample holder.

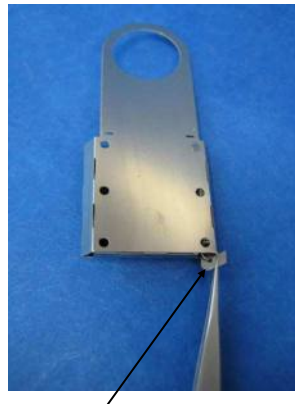

Solution - 3. Relocate the retaining catch within the locating slot.

Continued from page 35.

The retaining catch needs relocating within the locating slot of the sample holder as shown.

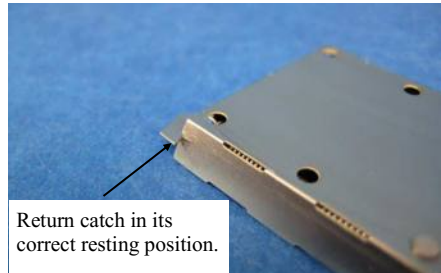
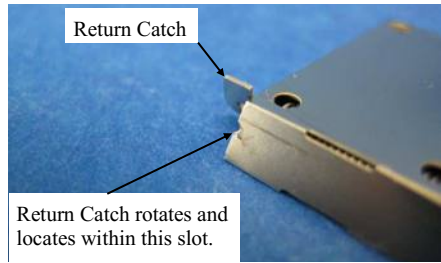

The sample holders must be loaded into the BCS196 stage as detailed below:

1. Begin to load the sample holder into the stage (see page 11 for additional information)

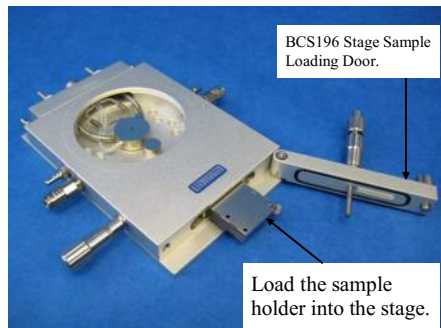

2. Check that the return catch locates within the alignment slot inside BCS196 stage correctly. If this return catch does not rest in the correct position, the user will have trouble closing the door. If forced, the sample holder could become damaged.

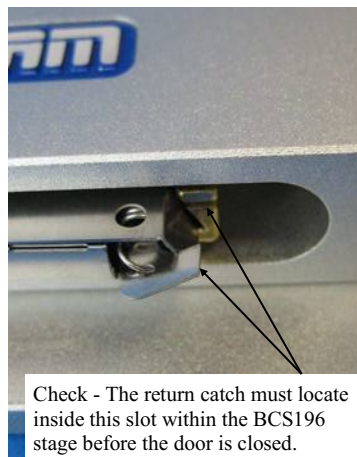

Using the Quench Cooling Manipulator

The Manipulator Rod (1) pushes the sample holder to quickly transfer the sample from the Warm Post (2) to the pre-cooled silver block (3). This method is used for high speed quench cooling in vitrification, enabling speeds up to 5000°C/min.

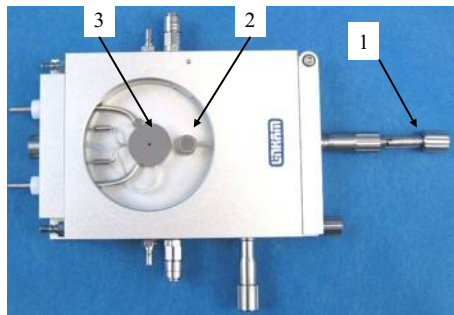

First ensure that the Push-manipulator is in the pushed in position.

Hold X manipulator (4) with one hand, then grip the end of the push manipulator (5) in the other, give it a 1/4 turn anti clockwise to make sure the locating pin is in the long slot and not the locked position, then push the manipulator all the way until it stops.

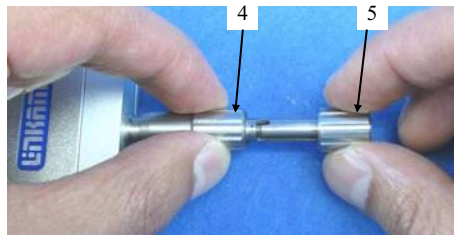

Give it a 1/4 turn clockwise and pull back a few mm to locate the locking pin into the locked position. The manipulator now functions as a normal sample manipulator in the X direction.

Now slide in the G7T in to the Sample Chamber as described for the BCS/CC (see page 11).



Place a W7S sapphire window using the vacuum tweezers onto the surface of the silver block next to the end of the sample holder.



Using a pair of tweezers carefully lift the G7T about 1mm off the silver heating block and slide the W7S 7mm sapphire window underneath the end of the sample holder. It should clip into place.

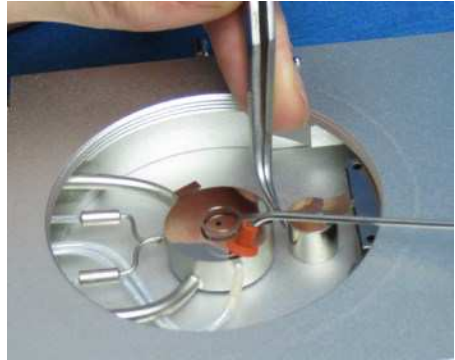

If necessary use the edge of the vacuum tweezers sucker to locate the W7S into the sample holders..

Adjust the XY-manipulators (1) by a few turns in both directions to make sure the W7S is fitted securely in place.

Now load the sample onto the W7S.



In order to vitrify the sample the sample holder must be moved to the warm post before cooling the silver block to the specified temperature.

Do this by pushing the Push-manipulator in toward the stage a couple of mm, give it a quarter turn and pull out away from the stage.



Now replace the Lid and purge the stage (see section on purging) ready for cooling.

When silver block is at the desired temperature you can push/transfer the sample from the warm post to the precooled silver block and lock the manipulator into position. When locked, you can move the sample using both X and Y manipulators.

Sample Seeding with Seeding Post

This allows a crystal to grow from a single point from the Seeding Post (1). A small block of silver mounted to the cooling inlet forms a cold spot at -196°C which acts as the seeding point in the cooling procedure outlined below.

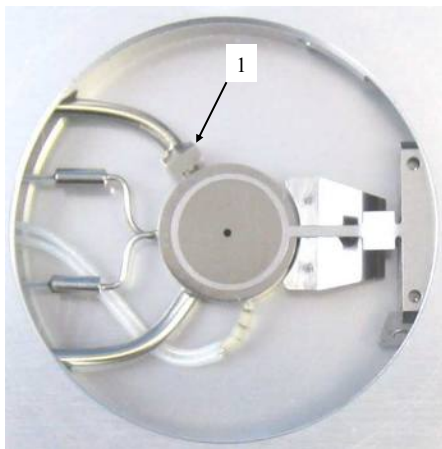

Make sure that the tube from the Dewar flask is connected to the inlet pipe (2) which passes through the seeding point

1. Prepare the sample as described in the manual using a G16.
2. Adjust the X-Y manipulators so that the sample assembly is placed centrally on the silver block.
3. Find out where the sample melts by freezing the sample and then slowly heating ($5^{\circ}\text{C}/\text{min}$). Note when the last crystal melts.
4. Use the X-Y manipulators move the sample over to the seeding point.
5. Replace the lid and cool to between 0.5 and 1°C above the melting point measured in step 3.
6. Leave the sample in this position for about 2 minutes and then move it back to the centre of the silver block.
7. Slowly program the temperature to cool down at about $5^{\circ}/\text{min}$ or slower and observe the crystals growing from the seeding point.

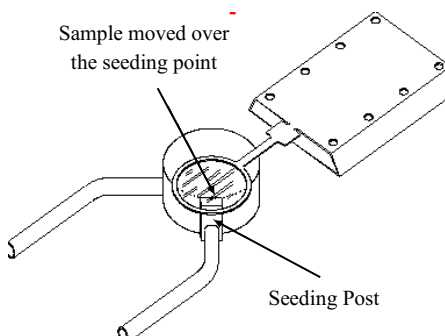
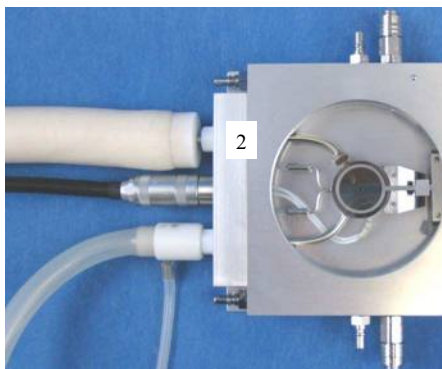

Alternate Configuration: HFS600E-PB4/PB2

Thank you for purchasing the Examina HFS600E-PB4/PB2 Temperature Controlled Probe system. Please take the time to read through the manual as it will help you to make the most out of the equipment.

HFS600E-PB4/PB2 Stage Specifications

Stage:

Maximum Temperature : 600°C
Minimum Temperature : -196°C (with LNP95)
Maximum heating rate: 150°C/min
Min Objective Lens WD: 4.7mm
Min Condenser lens WD: 12.5mm
Aperture hole: 2mm

Probe:

Maximum voltage: 300V AC
Maximum ampere: 4A

HFS600E-PB4/PB2 System

The system consists of a HFS600E-PB4/PB2 stage with 4x/2x BNC Connectors, a T95-LinkPad System Controller and optional LNP95 liquid nitrogen cooling pump for cooling to -196 ° C.

LINK System control software and digital video capture can be added as an option to control from PC.

The HFS600E-PB4/PB2 stage is mounted onto the microscope by using either specific stage clamps, an adaptor plate or by simply placing on the XY table of the microscope, using double sided adhesive tape.



HFS600E-PB4 Stage



HFS600E-PB4/PB2 System with
LNP95

HFS600E-PB4 Stage Anatomy

Stage Assembly

1. Lemo connector for stage lead
2. Heating element carrier assembly
3. Stage body
4. Inlet/Outlet Gas connector
5. Stage body water connector
6. Bypass stage body water cooling connector
7. Liquid nitrogen cooling connector
8. Earth safety contact for lid
9. Stage chamber
10. Outlet/Inlet Gas Connector
11. BNC connector

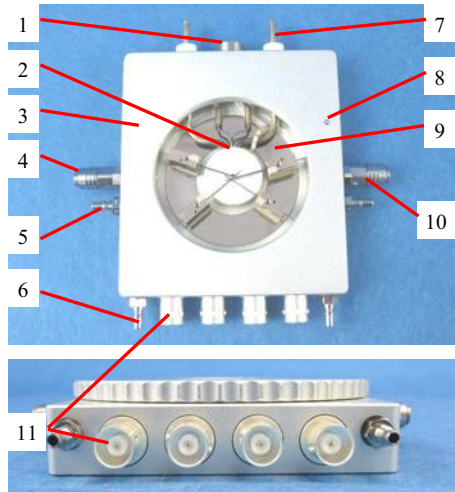

14. Heating element wire
15. Stainless steel cooling tube
16. Platinum temperature sensor
17. Probe
18. Metal plate for probe
19. Pure silver heating/cooling block
20. Aperture hole

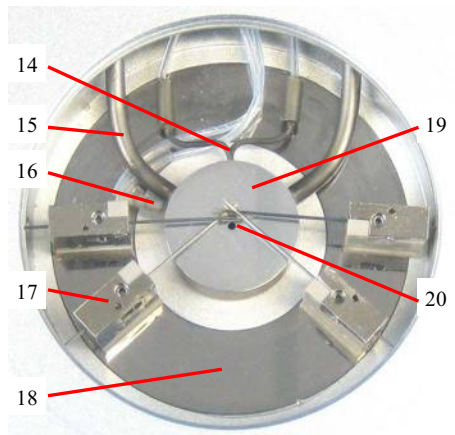

Lid Assembly

The Stage Lid is removed from the stage by unscrewing anti-clockwise.

21. Stage lid
22. Window Locking Ring
23. Glass Viewing Window
24. Holes for Tube Clip Holder or window removal tool

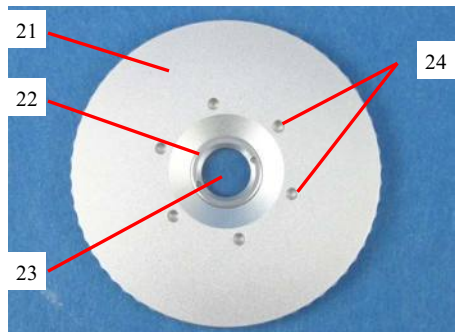

Probe Preparation

Remove the Probe

The HFS600E-PB4/PB2 is supplied with 4 tungsten gold plated tip Probes. The probe assembly (1) has a magnetic base and is held in place by the circular metal plate (2) inside the stage chamber .

Grip the probe and lift up to remove the probe from the stage.

Note: the Probe has a very sharp needle tip, be careful not to hurt yourself with it.

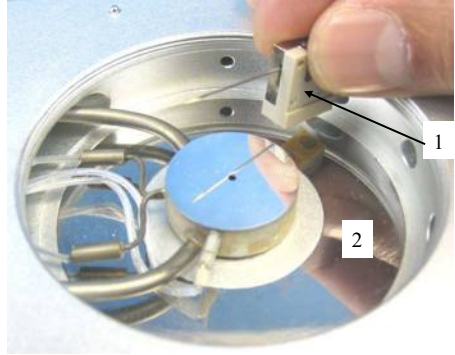

BNC Wire Connection

Use an adjustable spanner (3) or a pair of pliers and unscrew the BNC socket on the side of the HFS600E-PB4/PB2 stage.

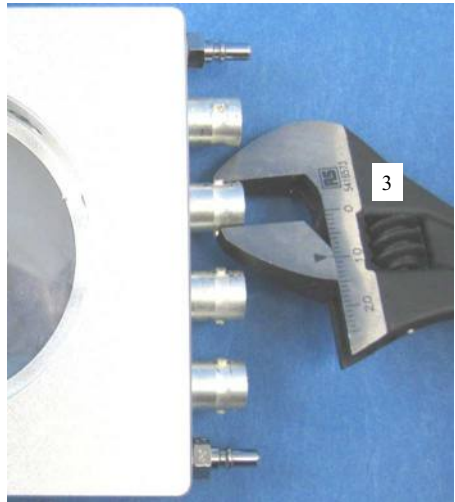

Cut a piece of the supplied yellow wire and strip 5mm of the insulation.

Fold the bare wire in half.

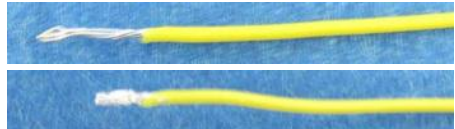

Solder the wire to the end of the BNC Socket as shown and screw the BNC socket back to the HFS600E-PB4/PB2 stage.



Wire your BNC cable to the supplied BNC plug.



Plug the BNC plug into the BNC Socket.

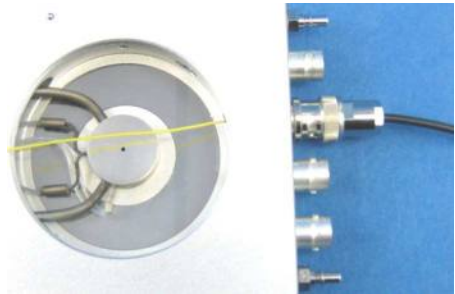

Probe Wire Connection

Cut the other end of the yellow wire to the desired length and strip 5mm of the insulation.

Fold the bare wire in half.

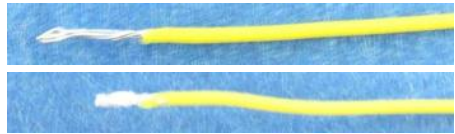

Use the supplied M1 Hex Key (1) and turn the grub screw (2) on the side of the Probe Assembly 3-4 turns anti-clockwise.

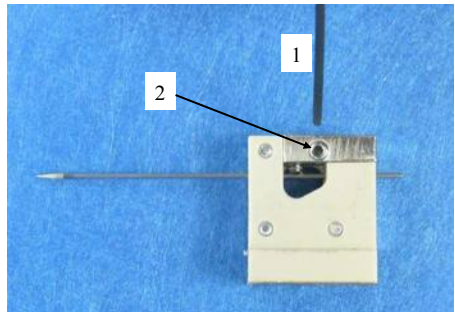

Insert wire into hole (3) as far as it can go and tighten the grub screw to lock the wire in place.

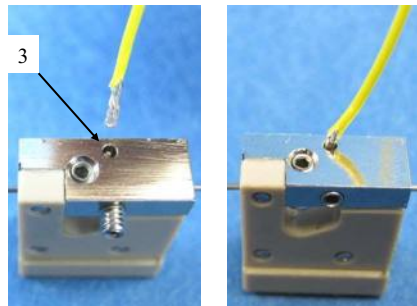

Adjusting the Probe

Probe orientation:

The probe has a magnetic base (1) and can be placed in any orientation inside the HFS600E-PB4/PB2 stage.

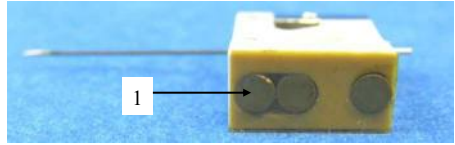

The circular metal ring (2) holds the magnetic foot of the Probe in place.

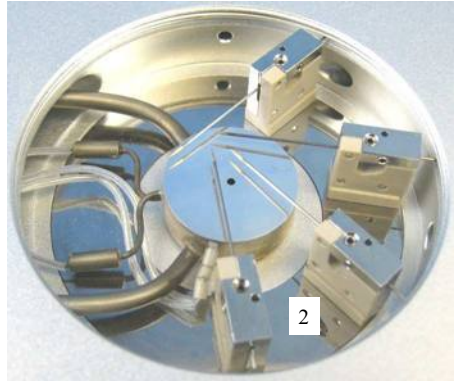

Adjust the length of the needle:

Pull end of the needle to the desired length and use a wire cutter to cut the needle shorter.



Bend the tip of the needle:

Use a pair of flat pliers to bend the tip of the needle.

Note: this action can only be done once. Tungsten metal is brittle and bending it again will break the needle.

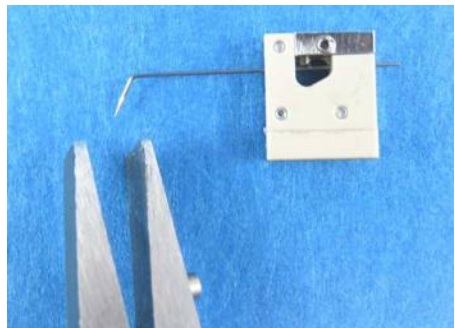

Change the angle of the needle:

Use the supplied M1 Hex Key (1) to shorten or lengthen the grub screw (2) to change the angle of the needle.

Note: the probe is spring loaded and makes better contact with the sample if the needle is adjusted a fraction lower than the sample.

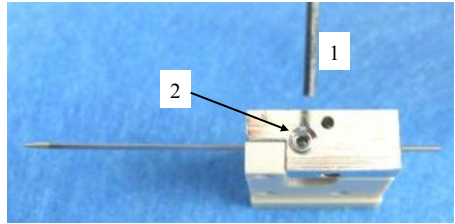

HFS600 Window Assembly

Lid Window Assembly

To replace the windows in the Stage Lid (1) use the Window Tool V2 (2) and align the two wide spacing pins to the Tube Clip Holder holes and unscrew the Lid Insert (3).

The Lid Insert should be screwed down until the cover slips are held firmly, then turn the assembly over and screw down the Lid Insert until it is felt to come to a stop.

This is the same principle for the Ellipsometer Lid top window assembly.

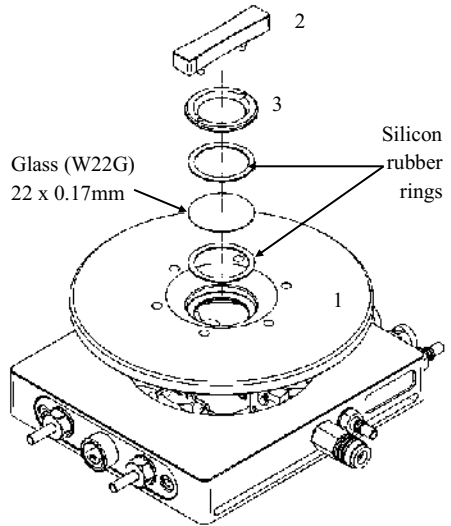

Ellipsometer Side Windows Assembly

Use the Side Window Locking Tool (5) to remove the Side Window Locking Ring (6) and reassemble the Side Window as shown in the diagram

6. Side Window Locking Tool
7. Side Window Locking Ring
8. Silicon Rubber Ring (17 x 12mm)
9. Side Window (up to 5mm thick)

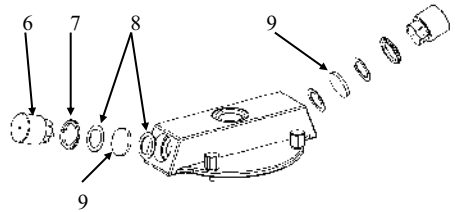

Bottom Window Assembly

Use two narrow spacing pins of Window Tool (4) to align it to the two holes of Window Locking Ring (5) and unscrew.

Reassemble the bottom window as shown in the opposite diagram.

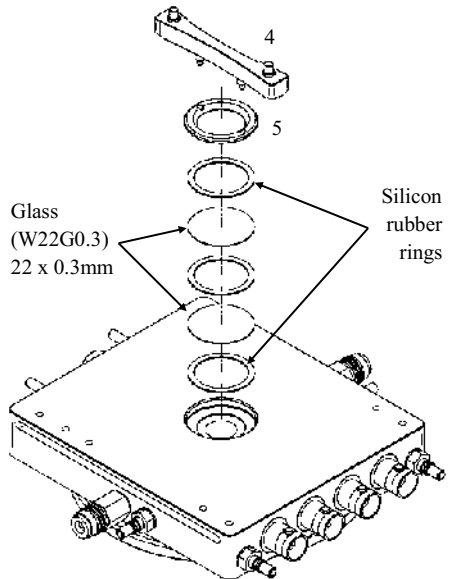

This page is intentionally blank

