



# Instructions for Use

**AU480 Chemistry Analyzer Addendum for ISE Tubing Maintenance**

For *In Vitro* Diagnostic Use



B97470AA  
August 2016



Beckman Coulter, Inc.  
250 S. Kraemer Blvd.  
Brea, CA 92821 U.S.A.



## Instructions for Use

### AU480 Chemistry Analyzer Addendum for ISE Tubing Maintenance

PN B97470AA (August 2016)

© 2016 Beckman Coulter, Inc.

All Rights Reserved.

## Trademarks

Beckman Coulter, the stylized logo, and the Beckman Coulter product and service marks mentioned herein are trademarks or registered trademarks of Beckman Coulter, Inc. in the United States and other countries.

All other trademarks are the property of their respective owners.

**EC REP**

Beckman Coulter Ireland Inc.  
Lismeehan, O'Callaghan's Mills,  
Co. Clare, Ireland  
Phone: +353-65-683-1100  
FAX: +353-65-683-1122

Beckman Coulter do Brasil Com e Imp de Prod de Lab Ltda  
Caçada Aldebarã, 39, Centro De Apoio 2 - Alphaville,  
Cep 06541-055 - Santana De Parnaíba, Sp, Brasil  
Telefone: (11) 4154-8818 - CNPJ: 42.160.812/0001-44

製造販売業者: ベックマン・コールター株式会社  
〒 135-0063  
東京都江東区有明三丁目 5 番 7 号  
TOC 有明ウエストタワー

贝克曼库尔特有限公司，  
美国加利福尼亚州，Brea 市，S. Kraemer 大街 250 号，  
邮编：92821 电话：(001) 714-993-5321

Beckman Coulter KK  
贝克曼库尔特株式会社  
東京都江東区有明三丁目 5 番 7 号  
邮编：135-0063

Rx Only  
Original Instructions

# Revision History

This document applies to the latest software listed and higher versions. When a subsequent software version changes the information in this document, a new issue will be released.

**Initial Issue, B97470AA, August 2016**

Software version 1.91

**Revision History**

# Contents

	Revision History, iii
<b>CHAPTER 1:</b>	<b>Introduction, 1-1</b>
	Description, 1-1
	ISE Tubing 4, 1-1
<b>CHAPTER 2:</b>	<b>ISE Maintenance, 2-1</b>
	ISE Maintenance Every Other Week or Every 3,000 Samples, 2-1
	Manually Clean the ISE Mix Bar, Liquid Level Sensors, and Sample Pot, 2-1
	ISE Maintenance Monthly, Every Two Months, or Every Three Months, 2-4
	Replace ISE Tubing, 2-4
	Quarterly or Every 20,000 Samples, 2-12
	Manually Clean the Drain Well, 2-12
	ISE As Needed Maintenance, 2-14
	Manually Clean the Sample Pot Tubing and Bypass Tubing, 2-14

## Contents

## Description

The AU480 User's Guide, ISE (Option) Maintenance section will be updated with a new Replace ISE Tubing procedure using ISE Tubing 4 at the next revision.

The new Replace ISE Tubing procedure and ISE Tubing 4 provide a simplified, more efficient maintenance process with improved ISE reliability and performance. For more information, refer to [Replace ISE Tubing](#).

With this new procedure, we have changed the ISE maintenance procedures as follows:

**Table 1.1** Changes to ISE Maintenance

Current ISE Maintenance in AU480 User's Guide	New ISE Maintenance in AU480 ISE Tubing Addendum
<b>Every Other Week or Every 3,000 Samples</b>	
Manually Clean the ISE Mix Bar, Liquid Level Sensors and Sample Pot, and Sample Pot Tubing	Manually Clean the ISE Mix Bar, Liquid Level Sensors and Sample Pot
<b>Monthly, Every Two Months, or Every Three Months: The maintenance frequency depends on the amount of samples processed per day in your laboratory.</b>	
N/A	Replace ISE Tubing
<b>Quarterly or Every 20,000 Samples</b>	
Manually Clean the Drain Well, and if Needed, Replace the Drain Tube	Manually Clean the Drain Well
Replace the Mixture Aspiration and MID Standard Roller Pump Tubing	Not Required
Replace the Tubing between Sample Pot, Electrode Unit and T-Connector	Not Required
Replace the REF Electrode Block-side Drain Tube and Pinch Valve Tubing	Not Required
<b>As Needed</b>	
N/A	Manually Clean the Sample Pot Tubing and Bypass Tubing

**IMPORTANT**

Perform all other ISE maintenance procedures and frequencies according to the ISE (Option) Maintenance section in the AU480 User's Guide.

### ISE Tubing 4

ISE Tubing 4 contains a flow cell tubing and a MID Standard roller pump tubing.

## Introduction

### Description

The flow cell tubing consists of the following five current components:

1. Tube set: Sample pot tubing and bypass tubing labeled 5
2. Tube set 2: REF electrode block side drain tube labeled 6
3. Pinch valve tubing
4. Mixture aspiration roller pump tubing
5. Metal plate with drain tube



## ISE Maintenance Every Other Week or Every 3,000 Samples

Perform the following procedures every other week or every 3,000 samples, whichever comes first.

- [Manually Clean the ISE Mix Bar, Liquid Level Sensors, and Sample Pot](#)

### Manually Clean the ISE Mix Bar, Liquid Level Sensors, and Sample Pot

To obtain accurate results and optimum system performance without unexpected system downtime, perform the following ISE maintenance procedure every two weeks or every 3,000 samples, whichever comes first. Clean according to your laboratory procedures and after careful monitoring of calibration and QC data.

For more information, refer to [Figure 2.4 ISE Tubing Block Diagram](#).

**Figure 2.1** ISE Mix Bar, Liquid Level Sensors, Nozzles, and Sample Pot

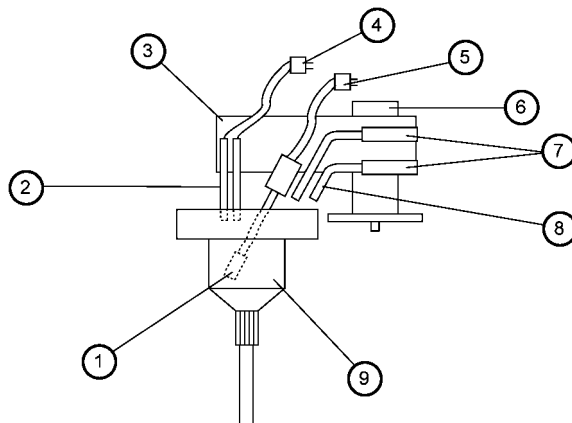

- |                           |                          |
|---------------------------|--------------------------|
| 1. Mix bar                | 6. Mixing component knob |
| 2. Liquid level sensor    | 7. Connecting tubing     |
| 3. Mixing component       | 8. Nozzle                |
| 4. Level sensor connector | 9. Sample pot            |
| 5. Mixing motor connector |                          |

### Prepare the ISE for Maintenance



Always prepare the ISE for maintenance procedures. The preparation procedure prevents the automatic ISE MID Standard Solution periodic (hourly) priming cycle from dispensing ISE MID Standard Solution.

- 1 Confirm that the system is in *Warm up* or *Standby* mode.

## ISE Maintenance

ISE Maintenance Every Other Week or Every 3,000 Samples

- 2 Select **Home > Analyzer Maintenance > ISE Maintenance > Maintenance**. The system displays the ISE Maintenance: Maintenance tab.
- 3 Select the **ISE Maintenance** box. The system activates the maintenance operation buttons.
- 4 Select **Drain Bypass**. The system displays the Start dialog.
- 5 Select **OK**.
- 6 Lift the upper cover of the analyzer.
- 7 Open the ISE cover.
- 8 Press the **TABLE ROTATION/DIAG** button. The liquid drains from the bypass tubing.

### Clean the Nozzles, Mix Bar, and Liquid Level Sensors

Materials Required:

- Alcohol prep pads (70% Isopropyl alcohol)
- Clean, dry, lint-free absorbent tissue

- 1 Disconnect the level sensor connector 714 and mixing motor connector 706.
- 2 Loosen the knob securing the mixing component. Gently lift the mixing component to unseat it.



Do not bend or break the liquid level sensors when cleaning.

- 3 Use an alcohol prep pad (70% Isopropyl alcohol) to wipe the two nozzles, the liquid level sensors, and the mix bar.

**Figure 2.2** Mixing Component

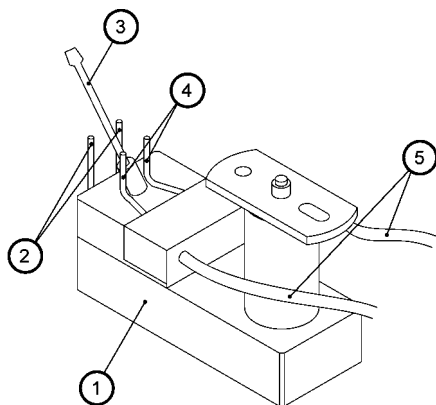

1. Mixing component
2. Liquid level sensors

3. Mix bar
4. Nozzles

## 5. Connecting tubing

---

- 4 Place the mixing component on the mixing component holder.

 **IMPORTANT**

Do not change the orientation position of the two nozzles attached to the mixing component. Do not apply excess pressure to the tubing.

---

### Clean the Sample Pot

For more information, refer to [Figure 2.4 ISE Tubing Block Diagram](#).

Materials Required:

- Freshly prepared 1% Wash solution
- Deionized water
- Clean, dry, lint-free absorbent tissue
- Sonicator
- Beaker

- 1 Loosen the retaining knob securing the sample pot, and lift the pot from the peg.
  - 2 Disconnect the sample pot tubing from the sample pot by unscrewing the connector.
  - 3 Submerge the sample pot into a beaker filled with 1% wash solution.
  - 4 Place the beaker in the sonicator filled with deionized water and sonicate for 10 minutes.
  - 5 Rinse the sample pot with deionized water.
  - 6 Use a clean, dry, lint-free absorbent tissue to dry the sample pot before replacement.
- 

### Reinstall the Sample Pot and Mixing Component

- 1 Reattach the sample pot tubing to the sample pot by screwing on the connector.
- 2 Reinstall the sample pot. Align the hole on the top of the sample pot with the peg and slide the screw post into the groove on the opposite side. Tighten the retaining knob.
- 3 Replace the mixing component on the two positioning pins. Tighten the knob to secure the mixing component.

 **IMPORTANT**

When reinstalling the mixing component, confirm that the tubing is not pinched between the mixing component and its stand.

## ISE Maintenance

### ISE Maintenance Monthly, Every Two Months, or Every Three Months



The connectors are specially keyed to fit each plug. To avoid damage to the pins, do not force a connector into its plug. If the pins are damaged, the mix bar does not rotate, or the liquid level sensors do not function.

- 4 Reconnect the level sensor connector 714 and mixing motor connector 706.
- 5 Select **Total Prime**. The system displays the Start dialog.
- 6 Select **OK**.
- 7 Press the **TABLE ROTATION/DIAG** button. The TABLE ROTATION/DIAG LED turns on after the prime is complete.
- 8 During the prime, confirm that buffer and MID Standard are correctly dispensed into the sample pot and flow to waste without generating alarms.
- 9 Close all analyzer doors and covers.
- 10 Clear the **ISE Maintenance** box to deactivate the maintenance operation buttons.
- 11 Update the Maintenance Log. For more information, refer to Update the Maintenance Log in the AU480 User's Guide.
- 12 To confirm that the ISE is working correctly after the maintenance procedure, perform a calibration.

## ISE Maintenance Monthly, Every Two Months, or Every Three Months

### Replace ISE Tubing

To obtain accurate results and optimum system performance without unexpected analyzer downtime, use the following maintenance frequencies to perform the Replace ISE Tubing procedure.

**Table 2.1** Criterion for Frequency of Replace ISE Tubing

Frequency	Patient Samples (with ISE Tests) Throughput per Day
Monthly	501 or more
Every Two Months	301 - 500
Every Three Months	1 - 300



You may need to replace the ISE tubing more frequently than specified in [Table 2.1 Criterion for Frequency of Replace ISE Tubing](#) after running more than 1,000 samples or

large volumes of dialysis samples, LIH (lipemic, icteric, or hemolyzed) samples, or serum samples containing separator material.

Materials Required:

- ISE Tubing 4 (Part Number B97644)

**Figure 2.3** ISE Tubing 4

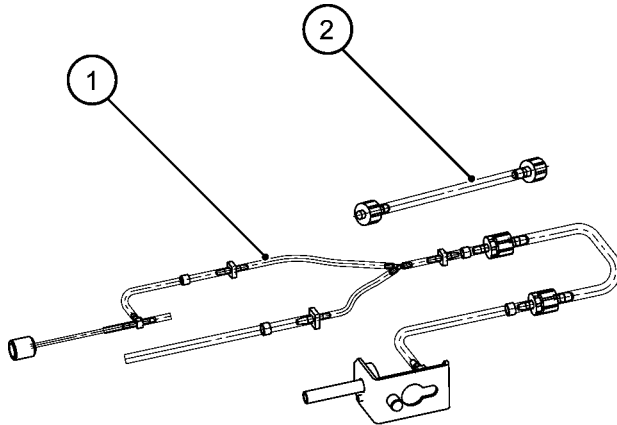

1. Flow cell tubing
2. MID Standard roller pump tubing

**Figure 2.4** ISE Tubing Block Diagram

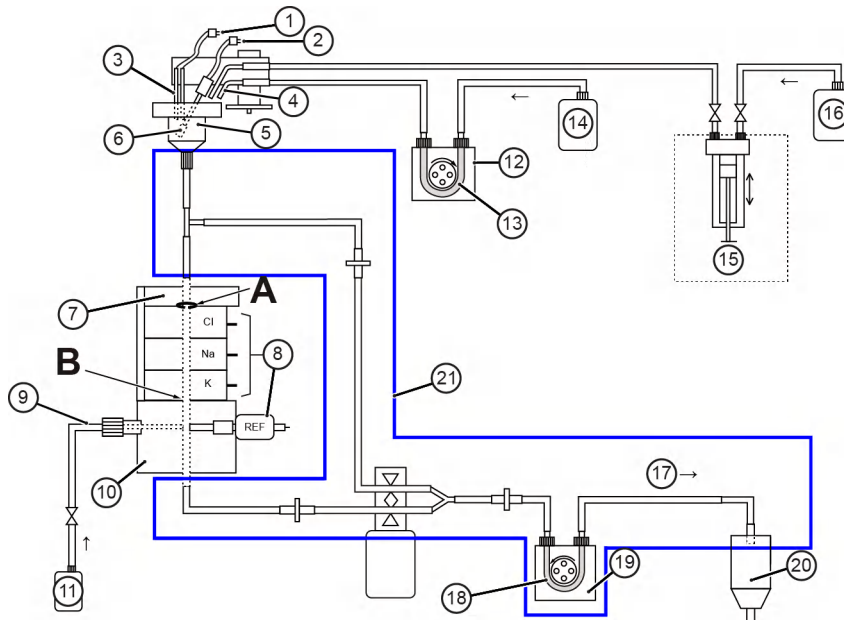

1. Level sensor connector
2. Mixing motor connector
3. Liquid level sensor
4. Nozzle
5. Sample pot
6. Mix bar
7. Electrode block (inlet)
8. Electrode
9. REF solution tube
10. REF electrode block
11. ISE Reference Solution
12. MID Standard roller pump
13. MID Standard roller pump tubing
14. ISE MID Standard Solution

## ISE Maintenance

ISE Maintenance Monthly, Every Two Months, or Every Three Months

- |   |                                    |
|---|------------------------------------|
| 15. Buffer syringe                        | 19. Mixture aspiration roller pump |
| 16. ISE Buffer Solution                   | 20. Drain well                     |
| 17. Waste solution                        | 21. Flow cell tubing               |
| 18. Mixture aspiration roller pump tubing |                                    |

### Prepare the ISE for Maintenance



Always prepare the ISE for maintenance procedures. The preparation procedure prevents the automatic ISE MID Standard Solution periodic (hourly) priming cycle from dispensing ISE MID Standard Solution.

- 
- 1 Confirm that the system is in *Warm up* or *Standby* mode.

---

  - 2 Select **Home > Analyzer Maintenance > ISE Maintenance > Maintenance**. The system displays the ISE Maintenance: Maintenance tab.

---

  - 3 Select the **ISE Maintenance** box. The system activates the maintenance operation buttons.

---

  - 4 Select **Drain Flowcell**. The system displays the Start dialog.

---

  - 5 Select **OK**.

---

  - 6 Lift the upper cover of the analyzer.

---

  - 7 Open the ISE cover.

---

  - 8 Press the **TABLE ROTATION/DIAG** button. The liquid drains from the flowcell.

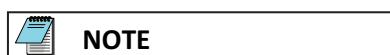

The first time you press the **TABLE ROTATION/DIAG** button, liquid is drained from the flowcell. Each additional time you press the **TABLE ROTATION/DIAG** button, the system primes ISE MID Standard Solution through the flowcell.

### Remove Flow Cell Tubing



Always drain the flow cell before moving the lock lever to release the electrode block. If the ISE Reference Solution is not drained, ISE Reference Solution can flow up into the electrodes and cause problems with the electrode measuring capability. ISE Reference Solution only flows past the REF electrode (not Na, K, or Cl electrode) in normal operation. ISE Reference Solution is more concentrated than the ISE MID Standard Solution or samples that flow through the flow cell.

- 
- 1 Remove the tubing from the pinch valve grooves by pulling it out and then up.

---

  - 2 Remove the roller pump tubing from the bracket of the mixture aspiration roller pump.

---

  - 3 Disconnect the liquid level sensor connector 714 and mixing motor connector 706.

---

  - 4 Loosen the knob securing the mixing component. Gently lift the mixing component to remove it.

---

  - 5 Place the mixing component on the mixing component holder.

 **IMPORTANT**

Do not change the orientation position of the two nozzles attached to the mixing component. Do not apply excess pressure to the tubing.

- 
- 6 Loosen the retaining knob securing the sample pot, and lift the pot from the peg.

---

  - 7 Disconnect the sample pot tubing from the sample pot by unscrewing the connector.

---

  - 8 Disconnect the other end of the sample pot tubing from the electrode block inlet.

---

  - 9 Disconnect the green REF electrode wire.

---

  - 10 Move the lock lever forward to release the electrodes.

- 
- 11 Remove the Na, K, and Cl electrodes from the electrode block to keep these electrodes away from the REF electrode. Any contact with the ISE Reference Solution can deteriorate the Na, K, and Cl electrodes.

 **IMPORTANT**

The system uses four O-rings in the electrode block. The O-ring attaches to the outlet side of each electrode and the metal part that contacts the Cl electrode (location A in the [Figure 2.4 ISE Tubing Block Diagram](#)). Do not lose the O-rings when removing the electrodes.

 **CAUTION**

**When lifting the electrodes, use your hand to support the electrodes. Do not lift the electrodes by the wires when they are still connected.**

- 
- 12 Gently lift up the REF electrode block.

---

  - 13 While holding the REF electrode block, disconnect the tubing (labeled 6) from the REF electrode block.

---

  - 14 Remove the drain tube with metal plate from the hook over the drain well.
-

## ISE Maintenance

ISE Maintenance Monthly, Every Two Months, or Every Three Months

### Connect New Flow Cell Tubing

Materials Required:

- Flow cell tubing contained in ISE Tubing 4

- 
- 1 Obtain the new flow cell tubing from ISE Tubing 4.

---

  - 2 Confirm that all joints and connectors of the new flow cell tubing are secured.

---

  - 3 Place the metal plate with drain tube on the hook over the drain well.

---

  - 4 Attach the flow cell tubing (labeled 6) to the REF electrode block.

---

  - 5 Place the REF electrode block in the original position and reconnect the green REF electrode wire.

---

  - 6 Install the three electrodes on the electrode block. Install the electrodes according to the label of Cl, Na, and K from the electrode block inlet side to the REF electrode block side.



Confirm that all four O-rings are in position before using the lock lever to secure the electrodes. The O-rings are necessary to create an airtight seal for the flow cell.

- 
- 7 Align the electrodes in a straight stack with the pegs in the holes.

---

  - 8 Move the lock lever backward to lock the electrodes in position.

---

  - 9 Connect the sample pot tubing of the flow cell tubing to the electrode block inlet.

---

  - 10 Connect the sample pot tubing of the flow cell tubing to the sample pot by screwing on the connector.



To attach the sample pot tubing to the sample pot, finger-tighten the connector.

- 
- 11 Reinstall the sample pot. Align the hole on the top of the sample pot with the peg and slide the screw post into the groove on the opposite side. Tighten the retaining knob.

---

  - 12 Replace the mixing component on the two positioning pins. Tighten the knob to secure the mixing component.

---

  - 13 Reconnect the level sensor connector 714 and mixing motor connector 706.



**IMPORTANT**

The connectors are specially keyed to fit each plug. To avoid damage to the pins, do not force a connector into its plug. If the pins are damaged, the mix bar does not rotate, or the liquid level sensors do not function.

**IMPORTANT**

When reinstalling the mixing component, confirm that the tubing is not pinched between the mixing component and its stand.

- 14** Place the roller pump tubing of the flow cell tubing on the mixture aspiration roller pump. Confirm that the tubing connector numbers match to their corresponding numbers on the pump bracket. Hook one end of the tubing in the bracket, stretch the tubing around the pump, and hook the other end in the bracket.

**Figure 2.5** Mixture Aspiration Roller Pump Tubing

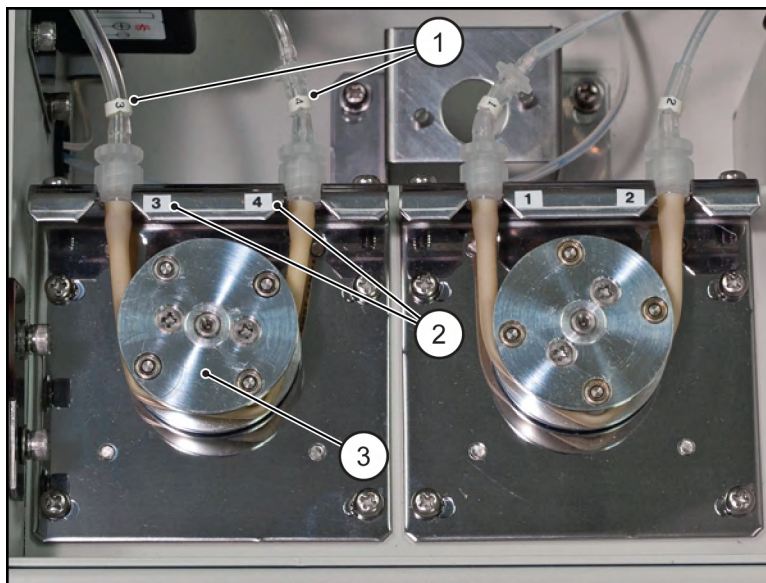

- |                             |                                   |
|-----------------------------|-----------------------------------|
| 1. Tubing connector numbers | 3. Mixture aspiration roller pump |
| 2. Numbers on pump bracket  |                                   |

**IMPORTANT**

Confirm that the tubing is not twisted on the roller pump.

- 15** Insert the tubing into the grooves of the pinch valve. Confirm that the tubing is inserted completely into the groove. Put tubing labeled 6 in the bottom groove of the pinch valve, and put tubing labeled 5 in the top groove of the pinch valve.

## ISE Maintenance

ISE Maintenance Monthly, Every Two Months, or Every Three Months

**Figure 2.6** Pinch Valve

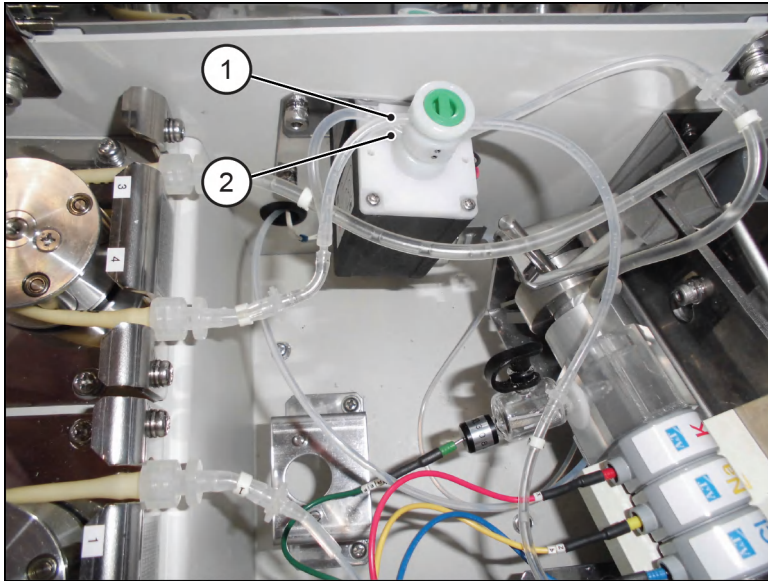

1. Tubing labeled 5 in top groove of pinch valve

2. Tubing labeled 6 in bottom groove of pinch valve

---

### Replace the MID Standard Roller Pump Tubing

Materials Required:

- MID Standard roller pump tubing contained in ISE Tubing 4.

- 
- 1 Remove the roller pump tubing from the bracket of the MID Standard roller pump.

---

  - 2 Disconnect the roller pump tubing by twisting apart the connectors at each end.

---

  - 3 Connect a new roller pump tubing. Turn the connectors at both ends to secure it.

---

  - 4 Place the roller pump tubing on the MID Standard roller pump. Confirm that the tubing connector numbers match their corresponding numbers on the pump bracket. Hook one end of the tubing to the bracket, stretch the tubing around the pump, and hook the other end to the bracket.



Confirm that the tubing is not twisted on the roller pump.

**Figure 2.7** MID Standard Roller Pump

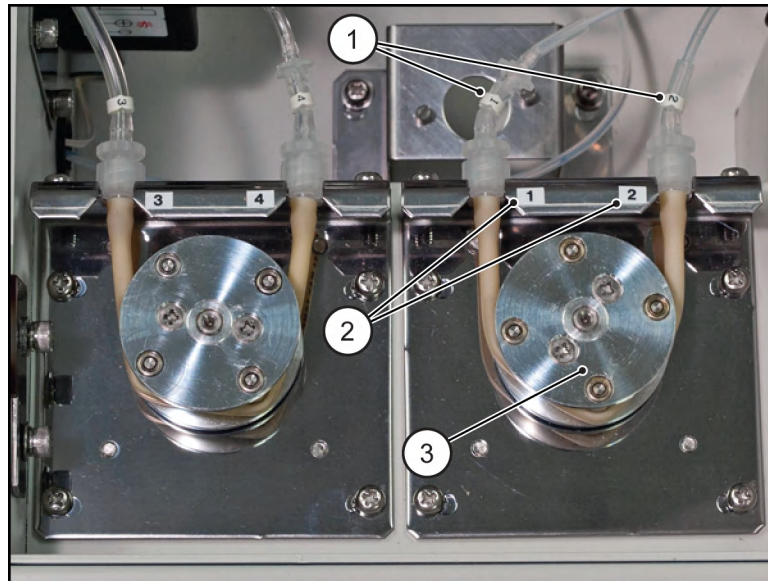

- |  |                                    |
|--|------------------------------------|
| <p>1. Tubing connector numbers<br/>                 2. Numbers on pump bracket</p> | <p>3. MID Standard roller pump</p> |
|--|------------------------------------|

---

**Prime the Tubing**

- 
- 1 Confirm that **Drain Flowcell** is selected.
- 
- 2 Press the **TABLE ROTATION/DIAG** button to reprime the lines with ISE MID Standard Solution. Confirm that liquid is correctly dispensed from the sample pot to the flowcell and that there are no bubbles in the REF electrode block side drain tube labeled 6.

 **NOTE**

You may need to repeat this step five times. If bubbles are in the tubing after priming, confirm that the electrodes and tubing are installed correctly, and the electrodes are secured with the lock lever.

- 
- 3 Select **Prime Bypass**. The system displays the Start dialog.
- 
- 4 Select **OK**.
- 
- 5 Press the **TABLE ROTATION/DIAG** button to start the prime. The two roller pumps are activated to prime liquid through the ISE. The roller pumps rotate for approximately one minute to remove the air from the tubing.
- 
- 6 Close all analyzer doors and covers.
- 
- 7 Clear the **ISE Maintenance** box to deactivate the maintenance operation buttons.
- 
- 8 Update the Maintenance Log. For more information, refer to Update the Maintenance Log in the AU480 User's Guide.

## ISE Maintenance

Quarterly or Every 20,000 Samples

- 
- 9 To confirm that the ISE is working correctly after the maintenance procedure, perform a calibration.
- 

## Quarterly or Every 20,000 Samples

---

### Manually Clean the Drain Well

If the system analyzes samples that contain large amounts of fibrin and protein, the fibrin and protein can accumulate by the drain tube outlet and drain well, possibly causing errors.

Manually clean the drain well quarterly.

For more information, refer to [Figure 2.4 ISE Tubing Block Diagram](#).

**Figure 2.8** Drain Well

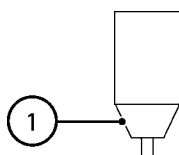

1. Drain well

Materials Required:

- Sodium hypochlorite solution (0.5%)

### Prepare the ISE for Maintenance

**IMPORTANT**

Always prepare the ISE for maintenance procedures. The preparation procedure prevents the automatic ISE MID Standard Solution periodic (hourly) priming cycle from dispensing ISE MID Standard Solution.

- 
- 1 Confirm that the system is in *Warm up* or *Standby* mode.

---

  - 2 Select **Home > Analyzer Maintenance > ISE Maintenance > Maintenance**. The system displays the ISE Maintenance: Maintenance tab.

---

  - 3 Select the **ISE Maintenance** box. The system activates the maintenance operation buttons.

---

  - 4 Select **Drain Flowcell**. The system displays the Start dialog.

---

  - 5 Select **OK**.

---

  - 6 Lift the upper cover of the analyzer.

---

  - 7 Open the ISE cover.

- 8 Press the **TABLE ROTATION/DIAG** button. The liquid drains from the flowcell.

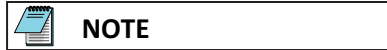

The first time you press the **TABLE ROTATION/DIAG** button, liquid is drained from the flowcell. Each additional time you press the **TABLE ROTATION/DIAG** button, the system primes ISE MID Standard Solution through the flowcell.

### Clean the Drain Well

- 1 Remove the drain well from the hook over the drain well.



**Wear Personal Protective Equipment (PPE) such as gloves, eye shields, and lab coats, to handle hydrochloric acid or sodium hypochlorite solution (0.5%). If the hydrochloric acid or sodium hypochlorite solution (0.5%) contacts skin or clothes, rinse the affected area thoroughly with water. If the hydrochloric acid or sodium hypochlorite solution (0.5%) contacts the eyes or mouth, immediately flush with water. Seek medical attention. Refer to the Safety Data Sheets (SDS) for more information. Follow your laboratory procedure to wipe up spills immediately.**

- 2 Prepare approximately 50 mL of sodium hypochlorite solution (0.5%).
- 3 Pour the sodium hypochlorite solution (0.5%) into the drain well directly from the top.
- 4 Allow the sodium hypochlorite solution (0.5%) to sit for approximately 10 minutes.
- 5 Pour deionized water into the drain well to rinse out the sodium hypochlorite solution.
- 6 Replace the drain tube over the drain well.
- 7 Press the **TABLE ROTATION/DIAG** button to reprime the lines with ISE MID Standard Solution. Confirm that liquid is correctly dispensed from the sample pot to the flow cell and that there are no bubbles in the REF electrode block side drain tube labeled 6.



You might need to repeat this step five times. If bubbles are in the tubing after the prime, confirm that the electrodes and tubing are installed correctly and that the lock lever secures the electrodes.

- 8 Close all analyzer doors and covers.
- 9 Clear the **ISE Maintenance** box to deactivate the maintenance operation buttons.
- 10 Update the Maintenance Log. For more information, refer to Update the Maintenance Log in the AU480 User's Guide.

## ISE As Needed Maintenance

---

### Manually Clean the Sample Pot Tubing and Bypass Tubing

Clean the sample pot tubing and bypass tubing if the sample pot tubing or bypass tubing becomes clogged or if you obtain erroneous calibration or QC results.



#### NOTE

You can perform [Replace ISE Tubing](#) instead of performing [Manually Clean the Sample Pot Tubing and Bypass Tubing](#) procedure. For more information, refer to [Replace ISE Tubing](#).



#### NOTE

The sample pot tubing and bypass tubing can become clogged and cause erroneous calibration or QC results after running the following samples:

- Large-volume dialysis patient samples
- LIH (lipemic, icteric, or hemolyzed) sample
- Serum sample that contains fibrin because centrifugal separation was not correctly conducted
- Serum sample that contains separator material which was aspirated because the serum volume was too low, or centrifugal separation was not correctly conducted



#### NOTE

If the sample pot tubing or bypass tubing frequently becomes clogged, confirm that samples are correctly prepared.

### Prepare the ISE for Maintenance



#### IMPORTANT

Always prepare the ISE for maintenance procedures. The preparation procedure prevents the automatic ISE MID Standard Solution periodic (hourly) priming cycle from dispensing ISE MID Standard Solution.

- 
- 1 Confirm that the system is in *Warm up* or *Standby* mode.

---

  - 2 Select **Home > Analyzer Maintenance > ISE Maintenance > Maintenance**. The system displays the ISE Maintenance: Maintenance tab.

---

  - 3 Select the **ISE Maintenance** box. The system activates the maintenance operation buttons.

---

  - 4 Select **Drain Flowcell**. The system displays the Start dialog.

- 
- 5 Select **OK**.

---

  - 6 Lift the upper cover of the analyzer.

---

  - 7 Open the ISE cover.

---

  - 8 Press the **TABLE ROTATION/DIAG** button. The liquid drains from the flowcell.

 **NOTE**

The first time you press the **TABLE ROTATION/DIAG** button, liquid is drained from the flowcell. Each additional time you press the **TABLE ROTATION/DIAG** button, the system primes ISE MID Standard Solution through the flowcell.

**Remove the Sample Pot Tubing and Bypass Tubing**

**Figure 2.9** Sample Pot Tubing and Bypass Tubing

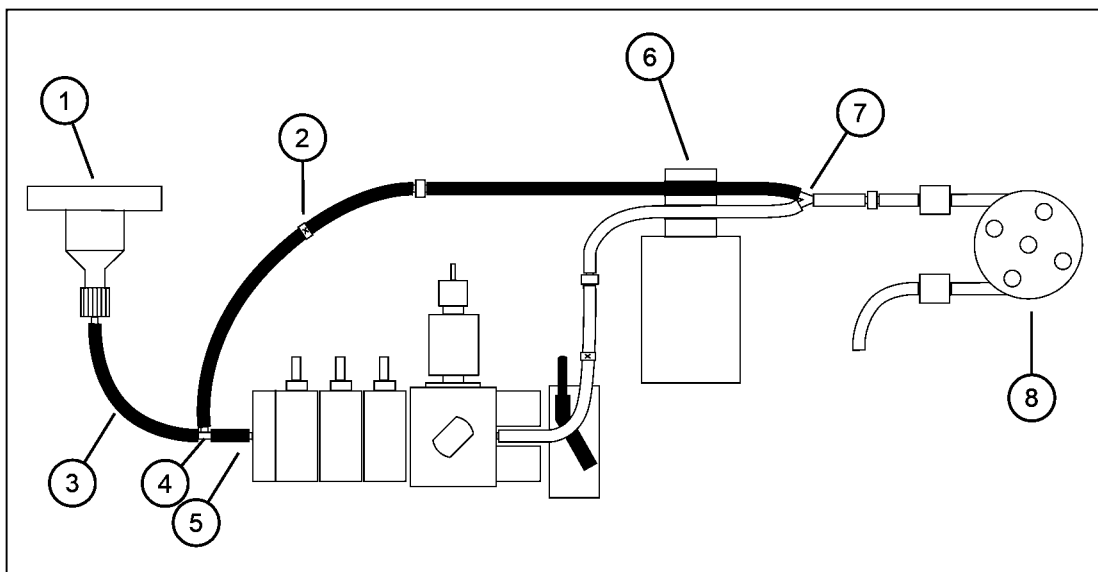

- |                            |                                   |
|----------------------------|-----------------------------------|
| 1. Sample pot              | 5. Electrode block inlet          |
| 2. Bypass tubing labeled 5 | 6. Pinch valve                    |
| 3. Sample pot tubing       | 7. Y-connector                    |
| 4. T-connector             | 8. Mixture aspiration roller pump |

- 
- 1 Disconnect the liquid level sensor connector 714 and mixing motor connector 706.

---

  - 2 Loosen the knob securing the mixing component. Gently lift the mixing component to remove it and place it on the mixing component holder.

---

  - 3 Loosen the retaining knob securing the sample pot, and lift the pot from the peg.

---

  - 4 Disconnect the sample pot tubing from the sample pot by unscrewing the connector. Put the sample pot aside.



- 
- 5** Disconnect the other end of the sample pot tubing from the electrode block inlet.

---

  - 6** Remove the bypass tubing labeled 5 from the top groove of the pinch valve.

---

  - 7** Disconnect the bypass tubing from the Y-connector near the mixture aspiration roller pump.
- 

### **Clean the Sample Pot Tubing and Bypass Tubing**

Materials Required:

- Freshly prepared 1% wash solution
  - Deionized water
  - Clean, dry, lint-free absorbent tissue
  - Sonicator
  - Beaker
  - Squeeze bottle with disposable pipette tip or syringe with disposable pipette tip
- 

- 1** Fill the sample pot tubing and bypass tubing with 1% wash solution. Use a disposable pipette tip attached to a squeeze bottle or a syringe to fill the sample pot tubing and bypass tubing.
  1. Attach the pipette tip or syringe to either end of the sample pot tubing.
  2. Force the 1% wash solution through the sample pot tubing.
  3. Attach the pipette tip or syringe to the end of the bypass tubing.
  4. Force the 1% wash solution through the bypass tubing.

**Figure 2.10** Sample Pot Tubing and Bypass Tubing



- 
- 2** Submerge the sample pot tubing and bypass tubing into a beaker filled with 1% wash solution.

---

  - 3** Place the beaker in the sonicator filled with deionized water and sonicate for 10 minutes.

---

  - 4** Rinse the sample pot tubing and bypass tubing with deionized water.
-



1. Attach the pipette tip or syringe to either end of the sample pot tubing.
  2. Force deionized water through the sample pot tubing.
  3. Attach the pipette tip or syringe to the end of the bypass tubing.
  4. Force deionized water through the bypass tubing.
  5. Confirm that the lines have been flushed thoroughly.
- 
- 5 Use a clean, dry, lint-free absorbent tissue to dry the sample pot tubing and bypass tubing before reconnecting them.



**NOTE**

If the sample pot tubing or bypass tubing remains clogged, or the system continues to generate erroneous calibration or QC results, perform the Replace ISE Tubing procedure. For more information, refer to [Replace ISE Tubing](#).

---

**Attach the Sample Pot Tubing and Bypass Tubing**

- 1 Connect the sample pot tubing to the electrode block inlet.
- 2 Attach the sample pot tubing to the sample pot by screwing on the connector.
- 3 Reinstall the sample pot. Align the hole on the top of the sample pot with the peg and slide the screw post into the groove on the opposite side. Tighten the retaining knob.
- 4 Connect the bypass tubing to the Y-connector located near the mixture aspiration roller pump.
- 5 Insert the bypass tubing in the top groove of the pinch valve. Confirm that the tubing is inserted completely into the groove.
- 6 Replace the mixing component on the two positioning pins. Tighten the knob to secure the mixing component.
- 7 Reconnect the level sensor connector 714 and mixing motor connector 706.



**IMPORTANT**

The connectors are specially keyed to fit each plug. To avoid damage to the pins, do not force a connector into its plug. If the pins are damaged, the mix bar does not rotate, or the liquid level sensors do not function.



**IMPORTANT**

When reinstalling the mixing component, confirm that the tubing is not pinched between the mixing component and its stand.

---

## ISE Maintenance

### ISE As Needed Maintenance

#### Prime the Tubing

---

- 1 Confirm that **Drain Flowcell** is selected.
  - 2 Press the **TABLE ROTATION/DIAG** button to reprime the lines with ISE MID Standard Solution. Confirm that liquid is correctly dispensed from the sample pot to the flowcell and that there are no bubbles in the REF electrode block side drain tube labeled 6.
- 



#### NOTE

You may need to repeat this step five times. If bubbles are in the tubing after priming, confirm that the electrodes and tubing are installed correctly, and the electrodes are secured with the lock lever.

---

- 3 Select **Total Prime**. The system displays the Start dialog.
  - 4 Select **OK**.
  - 5 Press the **TABLE ROTATION/DIAG** button to start the prime. The TABLE ROTATION/DIAG LED turns on after the prime is complete.
  - 6 Close all analyzer doors and covers.
  - 7 Clear the **ISE Maintenance** box to deactivate the maintenance operation buttons.
  - 8 Update the Maintenance Log. For more information, refer to Update the Maintenance Log in the AU480 User's Guide.
  - 9 To confirm that the ISE is working correctly after the maintenance procedure, perform a calibration.
-



