

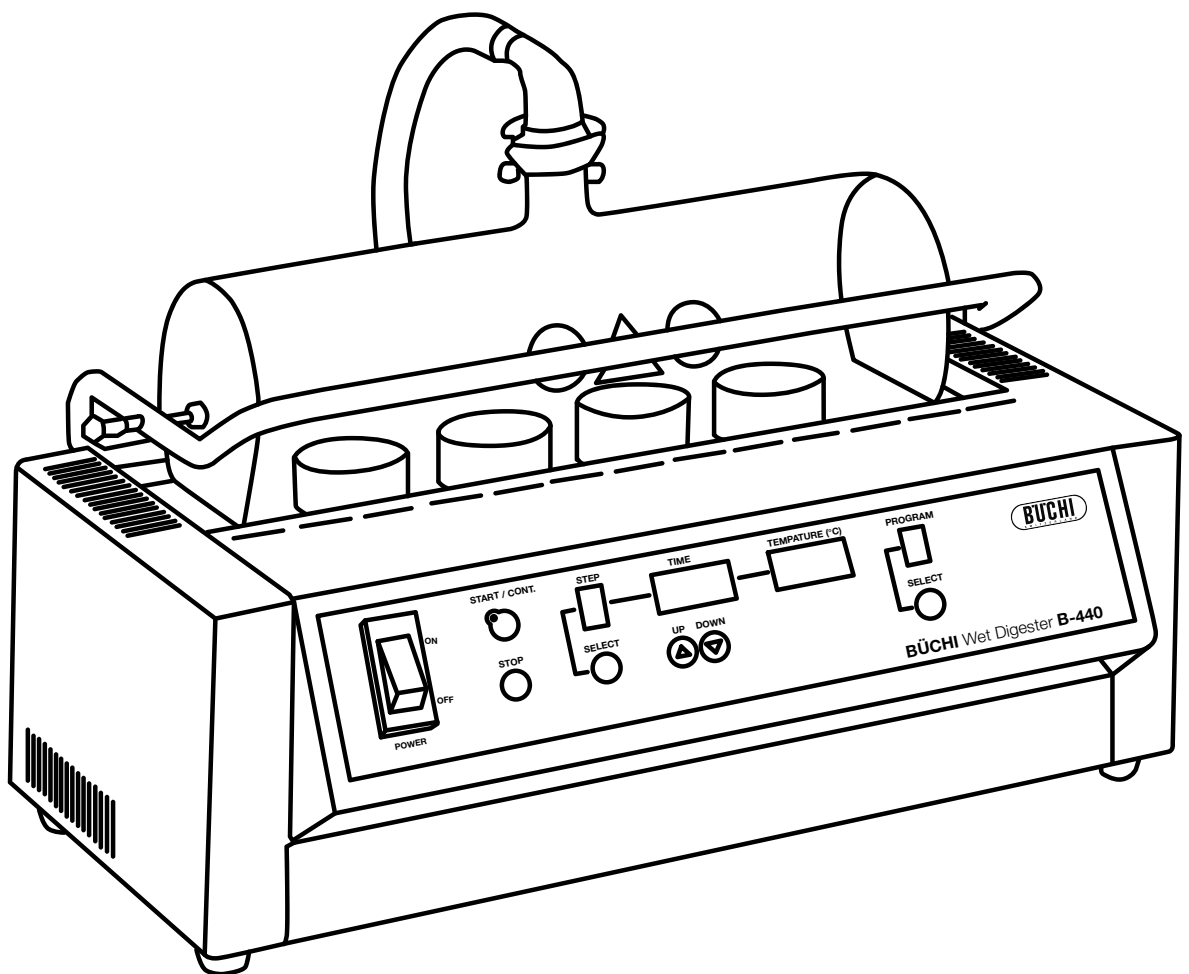

Wet Digester B-440

Technical data sheet

Instrument for parallel pre-incineration of samples with automatic acid fume exhaust. The B-440 is used in different industries such as pharmaceutical production, food quality control or environmental testing. Temperature/time profiles can be programmed and stored for optimal process safety, reproducibility and ease of use in routine work.



Scope of delivery

Each unit comprises a glass hood, condensate trap, mains cable and operating instructions.
The required ceramic plates and crucibles have to be ordered separately (see section Accessories).

Components	Qty
FKM hose 1.0 m	1
Corrugate hose	1
Crucible tongs	1

Order code

0 2 6 6 7 4 Wet Digester B-440

Technical data

Dimensions (WxHxD)	470 x 290 x 370 mm
Weight	12 kg
Storage capacity	9 methods (5 ramps with temperature/time profile)
Adjustable time range	0 – 240 minutes
Adjustable temperature range	10 – 600 °C
Holding capacity	4 or 6 crucibles
Power supply	220 – 240 V ±10 %
Frequency	50/60 Hz
Power consumption	1200 W
Ambient	5 – 40 °C, max. 80 % relative humidity

Accessories

	Qty	Order number	Picture
Vitrified ceramic plate with 6 holes, ø 39 mm	1	026661	①
Vitrified ceramic plate with 4 holes, ø 48 mm	1	036676	②
Vitrified ceramic plate with 4 holes, ø 56 mm	1	026663	③
Vitrified ceramic plate without holes	1	026982	
Ceramic crucible, ø 40 mm, H 32 mm, V 20 mL	1	026936	
Ceramic crucible, ø 50 mm, H 40 mm, V 49 mL	1	036675	
Ceramic crucible, ø 60 mm, H 48 mm, V 90 mL	1	026938	

	Qty	Order number	Picture
Condensate trap, complete with connectors	1	036119	④
Condensate trap, glass tube without connectors	1	036080	⑤
Glass hood	1	036081	⑥
K-415 TripleScrub ^{ECO} *	1	114152331	

* Additional Scrubber models see technical data sheet K-415

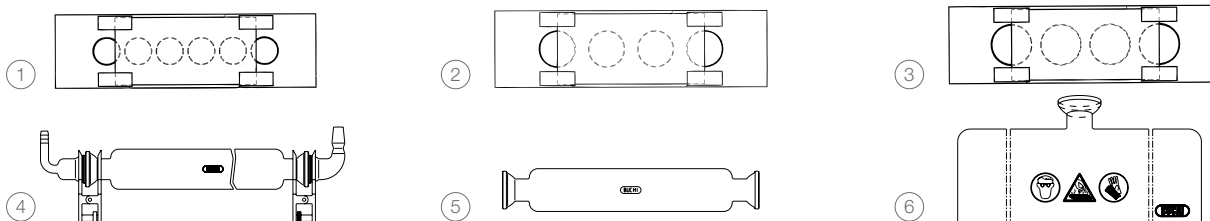

Functional principle

Heat is generated by a halogen lamp. Depending on the sample type, a suitable temperature/time profile is applied.

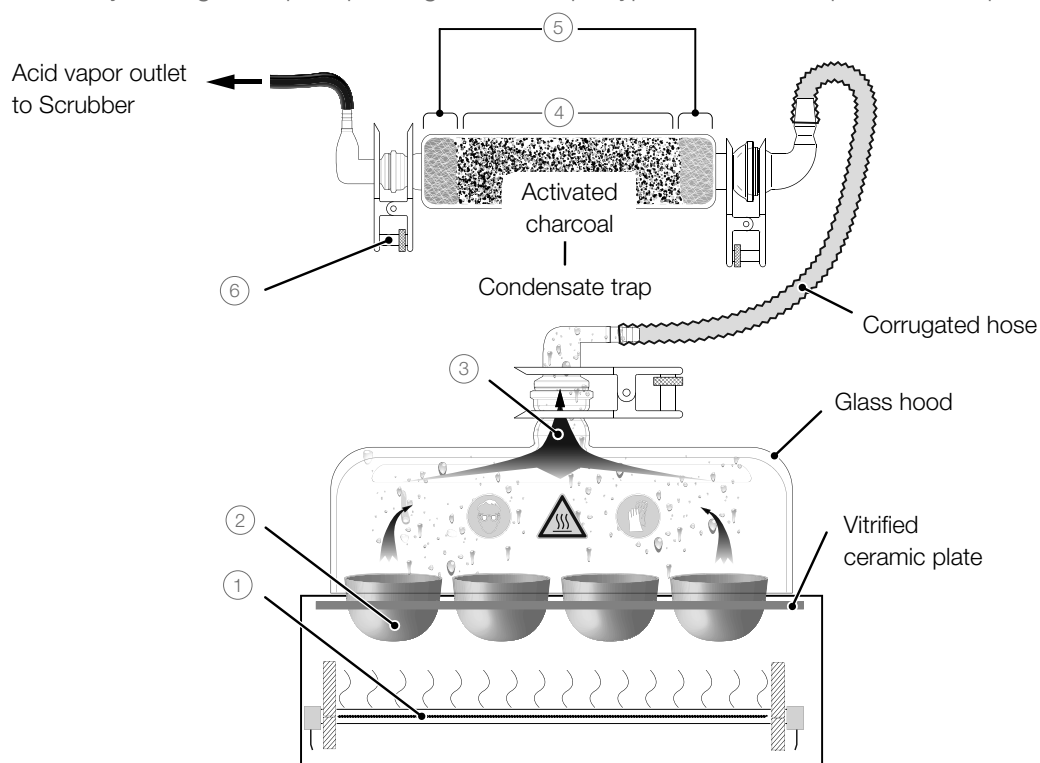

- The infrared heating ① generates high temperatures (up to 600 °C) to heat up the crucibles.
- Inside the crucibles ② the digestion process of the sample material takes place.
- Hot fumes ③ rise into the glass hood and are safely withdrawn by the suction flow of the Scrubber.
- The digestion fumes are highly corrosive and hazardous! The optional condensate trap is interconnected between the glass hood and the scrubber to neutralize most of the hazardous fumes in the first place.
- The activated charcoal ④ must be kept in place within a sandwich layer of glass wool ⑤ at each end of the condensate trap.
- Every glass-to-glass connection must be secured by a clip ⑥!

Quality in your hands