



**Agilent Technologies**

*Vacuum Products Division*

CE

# ***High Throughput Diffusion Pumps***

*HS-16*

*HS-20*

*HS-32*

*NHS-35*

*INSTRUCTION MANUAL*

Part No. 699901140

Rev. F

February 2018

# High Throughput Diffusion Pumps



*Viton® is a registered trademark of E. I du Pont de Nemours and Company.*

## Contents

<b>Diffusion Pump Hazards</b> .....	<b>7</b>
Explosion .....	8
Pressurization Hazards .....	9
Dangerous Substances .....	9
High Temperatures .....	10
High Voltages .....	10
Large Equipment and Heavy Weights .....	10
<b>Diffusion Pump Basics</b> .....	<b>11</b>
Pump Operation .....	11
Operating Characteristics .....	11
Pump Air Speed and Throughput .....	14
Physical Specifications .....	15
Unpacking .....	19
Setup .....	19
Assembly .....	19
Cleaning a New Pump .....	20
Cleaning Safety .....	20
Disassembly for Initial Cleaning .....	20
Reassembly After Initial Cleaning .....	20
<b>System and Utility Connections</b> .....	<b>21</b>
Vacuum Connections .....	21
Cooling Water .....	21
Electrical Connections .....	24
Overheating: Detection by Thermal Switches .....	25
<b>Initial Vacuum Test</b> .....	<b>36</b>
Adding or Changing Pump Fluid .....	37
Information on Fluid and DP Performance .....	37
<b>Operation</b> .....	<b>39</b>
Startup Procedure .....	40
Humid Environments .....	40
Shutdown Procedure .....	40
<b>Maintenance</b> .....	<b>41</b>
Periodic Inspections .....	41
Cleaning .....	42
Cleaning Safety .....	42
Disassembly and Reassembly Procedures .....	43
Cold Cap .....	43
Jet Assemblies .....	44
Heater Replacement Procedure .....	50
<b>Troubleshooting</b> .....	<b>51</b>
Leakage .....	51
Outgassing .....	51
Poor Pump or System Performance .....	52
<b>Replacement Parts</b> .....	<b>53</b>

# High Throughput Diffusion Pumps

## List of Figures

Figure	Caption	Page
1	HS-20 Diffusion Pump . . . . .	11
2	HS-16 Speed and Throughput Curves, 8.1 kW. 14	
3	HS-20 Speed and Throughput Curves . . . . .	14
4	HS-32 Speed and Throughput Curves . . . . .	14
5	NHS-35 Speed and Throughput Curves . . . . .	14
6	HS-16 Outline with ASA Flanges . . . . .	15
7	HS-20 Outline with ASA Flanges . . . . .	16
8	HS-32 Outline with ASA Flanges . . . . .	17
9	NHS-35 Outline with ASA Flanges. . . . .	18
10	HS-16/20 Cooling Water Connections . . . . .	21
11	HS-32/NHS-35 Cooling Water Connections. . . . .	22
12	HS-16 3-Phase Delta Circuit . . . . .	26
13	HS-16 3-Phase WYE Circuit . . . . .	27
14	HS-20 3-Phase Delta Parallel Circuit . . . . .	28
15	HS-20 3-Phase WYE Parallel Circuit . . . . .	29
16	HS-32 3-Phase Delta Parallel Circuit . . . . .	30
17	HS-32 3-Phase WYE Parallel Circuit . . . . .	31
18	HS-32 3-Phase Delta Series Circuit . . . . .	32
19	NHS-35 3-Phase Delta Parallel Circuit. . . . .	33
20	NHS-35 3-Phase WYE Parallel Circuit . . . . .	34
21	NHS-35 3-Phase Delta Series Circuit . . . . .	35
22	Sight Glass Assembly . . . . .	38
23	Cold Cap Assembly . . . . .	43
24	HS-16 Jet Assembly . . . . .	44
25	HS-20 Jet Assembly . . . . .	45
26	Jet Coupling Detail. . . . .	46
27	HS-32 Jet Assembly . . . . .	47
28	NHS-35 Jet Assembly. . . . .	49
29	Heater Element Assembly . . . . .	50

## List of Tables

Table	Title	Page
1	General Hazards. . . . .	7
2	Explosive Conditions. . . . .	8
3	Pressurization Hazards . . . . .	9
4	Operating Specifications . . . . .	12
5	HS-16: Dimensions and Weights. . . . .	15
6	HS-16 Flange Dimensions. . . . .	15
7	HS-20: Dimensions and Weights. . . . .	16
8	HS-20 Flange Dimensions. . . . .	16
9	HS-32: Dimensions and Weights. . . . .	17
10	HS-32 Flange Dimensions. . . . .	17
11	NHS-35: Dimensions and Weights . . . . .	18
12	NHS-35 Flange Dimensions . . . . .	18
13	Wiring Diagram Locations . . . . .	24
14	Thermal Cutout Temperatures. . . . .	25
15	HS -16 3 Phase Delta . . . . .	26
16	HS -16 3 Phase WYE . . . . .	27
17	HS -20 3-Phase Delta Parallel . . . . .	28
18	HS -20 3-Phase WYE Parallel. . . . .	29
19	HS -32 3-Phase Delta Parallel . . . . .	30
20	HS -32 3-Phase WYE Parallel . . . . .	31
21	HS -32 3-Phase Delta Series . . . . .	32
22	NHS-35 3-Phase Delta Parallel . . . . .	33
23	NHS-35 3-Phase WYE Parallel . . . . .	34
24	NHS-35 3-Phase Delta Series . . . . .	35
25	Troubleshooting Guide . . . . .	52
26	HS-16 Replacement Parts . . . . .	53
27	HS-20 Replacement Parts . . . . .	54
28	HS-32 Replacement Parts . . . . .	55
29	NHS-35 Replacement Parts . . . . .	56

## Preface

### Warranty

Products manufactured by Seller are warranted against defects in materials and workmanship for twelve (12) months from date of shipment thereof to Customer, and Seller's liability under valid warranty claims is limited, at the option of Seller, to repair, replacement, or refund an equitable portion of the purchase price of the Product. Items expendable in normal use are not covered by this warranty. All warranty replacement or repair of parts shall be limited to equipment malfunctions which, in the sole opinion of Seller, are due or traceable to defects in original materials or workmanship. All obligations of Seller under this warranty shall cease in the event of abuse, accident, alteration, misuse, or neglect of the equipment. In-warranty repaired or replaced parts are warranted only for the remaining unexpired portion of the original warranty period applicable to the repaired or replaced parts. After expiration of the applicable warranty period, Customer shall be charged at the then current prices for parts, labor, and transportation.

When products are used with toxic chemicals, or in an atmosphere that is dangerous to the health of humans, or is environmentally unsafe, it will be the responsibility of the Customer to have the product cleaned by an independent agency skilled and approved in handling and cleaning contaminated materials before the product will be accepted by Agilent, Inc. for repair and/or replacement.

Reasonable care must be used to avoid hazards. Seller expressly disclaims responsibility for loss or damage caused by use of its Products other than in accordance with proper operating procedures.

Except as stated herein, Seller makes no warranty, express or implied (either in fact or by operation of law), statutory or otherwise; and, except as stated herein, Seller shall have no liability under any warranty, express or implied (either in fact or by operation of law), statutory or otherwise. Statements made by any person, including representatives of Seller, which are inconsistent or in conflict with the terms of this warranty shall not be binding upon Seller unless reduced to writing and approved by an officer of Seller.

### Disclaimer

Operation and maintenance of this equipment involves serious risk. It is the responsibility of the user to maintain safe operating conditions at all times. Agilent assumes no liability for personal injury or damage resulting from operation or service of the equipment.

Agilent has no control over the use of this equipment and is not responsible for personal injury or damage resulting from its use. The safe use and disposal of hazardous or potentially hazardous materials of any kind is the sole responsibility of the user. Observe all WARNINGS and CAUTIONS to minimize the serious hazards involved.

It is the sole responsibility of the users of Agilent equipment to comply with all local, state and federal safety requirements (laws and regulations) applicable to their system. Employ the services of an industrial hygienist and/or a qualified chemical safety engineer in order to ensure safe installation and use.

### Warranty Replacement and Adjustment

All claims under warranty must be made promptly after occurrence of circumstances giving rise thereto, and must be received within the applicable warranty period by Seller or its authorized representative. Such claims should include the Product serial number, the date of shipment, and a full description of the circumstances giving rise to the claim. Before any Products are returned for repair and/or adjustment, written authorization from Seller or its authorized representative for the return and instructions as to how and where these Products should be returned must be obtained. Any Product returned to Seller for examination shall be prepaid via the means of transportation indicated as acceptable by Seller. Seller reserves the right to reject any warranty claim not promptly reported and any warranty claim on any item that has been altered or has been returned by non-acceptable means of transportation. When any Product is returned for examination and inspection, or for any other reason, Customer shall be responsible for all damage resulting from improper packing or handling, and for loss in transit, notwithstanding any defect or non-conformity in the Product. In all cases, Seller has the sole responsibility for determining the cause and nature of failure, and Seller's determination with regard thereto shall be final.

If it is found that Seller's Product has been returned without cause and is still serviceable, Customer will be notified and the Product returned at its expense; in addition, a charge for testing and examination may be made on Products so returned.

### Instructions for Use

This equipment is designed for use by professionals. The user should read this instruction manual and any other additional information supplied by Agilent before operating the equipment. Agilent will not be held responsible for any events that occur due to non-compliance with these instructions, improper use by untrained persons, non-authorized interference with the equipment, or any action contrary to that proved for by specific national standards.

This manual uses the following standard safety protocol:

#### **WARNING**



*The warnings are for attracting the attention of the operator to a particular procedure or practice which, if not followed correctly, could lead to serious injury.*

#### **CAUTION**



*The cautions are displayed before procedures, which if not followed, could cause damage to the equipment.*

#### **NOTE**



*The notes contain important information taken from the text.*

# Diffusion Pump Hazards

Designers of systems utilizing diffusion pumps must design out hazards wherever possible. For hazards that cannot be designed out, warnings, procedures, and instructions on proper use and servicing are provided. Please use guards, safety features, and interlocks as recommended.

Refer to Table 1 for a list of general hazards and recommended actions, Table 2 on page 8 for a list of prohibited actions that can result in explosions, and Table 3 on page 9 for a list of pressurization hazards that can result in damage to equipment.

THE INSTALLATION, OPERATION, AND SERVICING OF DIFFUSION PUMPS INVOLVES ONE OR MORE OF THE FOLLOWING HAZARDS, ANY ONE OF WHICH IN THE ABSENCE OF SAFE OPERATING PRACTICES AND PRECAUTIONS, COULD POTENTIALLY RESULT IN DEATH OR SERIOUS HARM TO PERSONNEL.

**Table 1 General Hazards**

Hazard	Suggested Corrective Action
Loss of utility: water and/or electricity	Provide sufficient backup water and power supply as necessary to effect a safe shutdown under worst case conditions
Overpressure in foreline	Provide an interlock to ensure that the power supply to the pump heater cannot be activated if the foreline pump is not running and/or the pressure in foreline is above 0.5 Torr (0.67 mbar)
Overtemperature	Fit temperature sensors and pump fluid level sensors with feedback to an interlock on the heater power supply
Insufficient water flow through the main cooling coils	Use water flow sensor and feedback to interlock the heater power supply
Water trapped between inlet and outlet of Quick Cool coil, or liquid nitrogen trapped between inlet and outlet of liquid nitrogen trap	Provide vent or pressure relief valves for both Quick Cool coil and liquid nitrogen trap
Loss of electrical ground integrity	Incorporate ground fault interrupt circuit into heater power supply
Positive pressure in pumping system	Integrate pressure relief valve in vacuum system to ensure system pressure does not exceed 1 atmosphere
High voltage	Prevent personnel contact with high voltages; design and attach warnings
Toxicity and Corrosivity	Vent toxic and/or corrosive gases to a safe location; ensure adequate dilution or scrubbing to safe levels; take all action required to meet air quality standards
Explosion	Integrate pressure relief valves
	Do not use hydrocarbon-based pumping fluids

## High Throughput Diffusion Pumps

### Explosion

- ❑ Operation of the diffusion pump without continuous evacuation below 0.5 Torr (0.67 mbar), or without coolant and introducing a strong oxidizer (such as air) or explosive vapors or powders or materials which may react with pumping fluids in a hot pump (above 300 °F or 150 °C) can cause an explosion. Such an explosion can violently expel valves and other hardware, slam open doors that are not designed for appropriate pressure relief, or burst other components of the vacuum system. Serious injury or death may result from expelled parts, doors, shrapnel, and shock waves.
- ❑ *Three elements are required for explosion:* fuel, oxidizer, and an ignition. A combination of temperature and pressure can be a source of ignition. Most diffusion pump fluids are fuels. Hydrocarbon fluids are more prone to oxidize and explode than synthetic silicone-based fluid. The oxidizer can be air, which can be introduced by a leak, deliberately brought in via a process, or inadvertently admitted by operator error. Oxygen and other strong oxidizers are even more dangerous than air. Certain conditions of temperature and pressure can cause a combustible mixture to explode. The larger the diffusion pump, the greater the risk of explosion and the greater the risk of damage and injury. Never operate large diffusion pumps utilizing hydrocarbon oils without a complete safety analysis for the entire system and for the application.
- ❑ *Explosion and Fire from Acetone and Alcohol:* Diffusion pumps are typically cleaned with acetone and alcohol. When combined with air, oxygen, and other oxides, alcohol and most other solvents are very flammable and explosive. Never permit any trace of these cleaners to remain in or on the pump. Always remove all traces of alcohol and acetone and other cleaners with clean, dry, oil-free compressed air.

Never operate a large diffusion pump under the conditions listed in Table 2. Any of these situations increases the probability of an explosion.

**Table 2 Explosive Conditions**

Prohibited Action	Explosion-Causing Condition
Do not run pump without cooling water	Overtemperature
Do not run pump with low level of pump fluid	Overtemperature
Do not run pump without proper backing or holding pump	Overpressure
Do not run pump when not evacuated below 0.5 Torr (0.67 mbar)	Overpressure
Do not admit air to, or rough through, a pump with hot boiler	Overpressure plus strong oxidizer
Do not open drain or fill plug while pump is under vacuum, especially when it is hot	Overpressure plus strong oxidizer
Do not contaminate pump with explosive vapors	Lower explosive threshold of gas mixtures
Do not remove, defeat, or override safety counter-measures such as pressure and thermal switches and valve sequencer interlocks	Overtemperature, overpressure, more combustible mixtures
Do not machine or weld any part of the pump without removing all fluid or solvent residue in pump	Source of ignition
Do not use unsuitable pumping fluid	Lower explosive threshold of gas mixture



## Pressurization Hazards

- ❑ Large vacuum pumps and their components are designed for vacuum service; they are not designed to be pressurized which could cause them to burst possibly expelling shrapnel at lethal velocities. Serious accidents have been caused by intentional pressurization of vacuum systems and their components.
- ❑ Never pressurize any part of a vacuum system for test or any other purpose.
- ❑ Always provide pressure relief when designing diffusion pumps into systems and ensure that pressure relief motion is limited to safe envelopes.
- ❑ Never permit the hazards in Table 3 to develop.

**Table 3 Pressurization Hazards**

Prohibited Action	Result
Do not block inlet or vent of liquid nitrogen trap and lines	LN <sub>2</sub> trap and/or lines burst
Do not close isolation valves at inlet and discharge of main water cooling coils when pump is heated	Water turns to steam and bursts coils
Do not pressurize the pump body (above 1 atm.)	Body of pump bursts
Do not make a hole through the vacuum wall	Loss of structural integrity of wall

- ❑ *Pressure Relief Devices:* Systems must be designed with pressure relief devices to provide safe pressure relief from internal explosions. Always recognize that safety devices can fail or malfunction; provide redundant protection by installing devices having different failure modes, failure mechanisms, and failure causes. Be certain that exhaust duct materials are capable of withstanding the corrosivity, temperature, and pressure of exhausted products.

## Dangerous Substances

- ❑ *Chemical Dangers of Acetone and Alcohol:* Diffusion pumps are typically cleaned with acetone or alcohol. Acetone, alcohol, and most other solvents are irritants, narcotics, and depressants, and/or carcinogenic. Their inhalation and ingestion may produce serious effects. Even absorption through the skin can result in moderate toxicity. Always ensure that cleaning operations are performed in large, well-ventilated rooms. Use of self-contained breathing apparatus may be necessary depending upon the solvent type and vapor concentration in surrounding air.
- ❑ *Poisonous and Corrosive Compounds:* When pumping poisonous, reactive, and/or corrosive gas, vapors, or chemicals, proper operation and regeneration do not always ensure that all hazardous materials have been totally removed. If hazardous gas, vapors, chemicals, or combustible mixtures are pumped, sufficient quantities may exist during operation or remain after regeneration to cause severe injury or death.
- ❑ *Pump Fluids:* Overheating the pump fluid, exposing it to air or reactive materials, or overpressurizing it above the normal operating range, approximately  $1 \times 10^{-3}$  Torr ( $1.3 \times 10^{-3}$  mbar) decomposes the fluid and possibly makes it toxic. This is especially true of backstreamed mechanical pump fluids which are more volatile (unstable). Overheating of accidentally introduced or backstreamed mechanical pump fluids cannot be protected against by thermal switches which are set for diffusion pump fluid.
- ❑ *Process Gasses:* Process gasses are frequently toxic, flammable, corrosive, explosive, or otherwise reactive. Agilent has no control over the types of gasses passing through the user's diffusion pump as these are entirely under the control of the process user and/or the hardware systems integrator. Since these gasses can cause serious injury or death, it is very important to plumb the exhaust of the pump to the facility's hazardous gas exhaust system which incorporates appropriate filters, scrubbers and similar components to ensure that the exhaust meets all air and water pollution control regulations.

## High Throughput Diffusion Pumps

---

### High Temperatures

- ❑ *Hot Surfaces:* Boiler temperatures reach 530 °F (275 °C) which can cause serious burns. Always ensure that surfaces have cooled to near room temperature before touching them.
- ❑ *Hot Cooling Water and Steam:* The water used to cool the pump can reach scalding temperatures. Touching or rupture of the cooling surface can cause serious burns. Water left inside Quick Cool coils from previous use turns to steam when the pump is reheated. This steam must be allowed to escape without contacting personnel. Whenever possible, design the water system with interlock valves so that power cannot be applied to the pump unless water is flowing in the main cooling coils (not Quick Cool coils).

### High Voltages

- ❑ Diffusion pump heaters operate at voltages high enough to kill. Design systems to prevent personnel contact with high voltages. Securely attach prominent hazard warnings. Personnel should always break the primary circuit to the power supply when direct access to the heater or wiring is required.

### Large Equipment and Heavy Weights

- ❑ The lifting and moving of large diffusion pumps requires power-assisted equipment and the use of trained moving and installation personnel to avoid dropping, slipping, and overturning the pump. Pumps weigh in excess of 500 lbs (226.8 kg) and are 3 to 6 feet in their largest dimension (1 to 2 meters). Their mishandling can cause severe injury. Check the weight of the equipment before lifting and assure that the power-assist device is adequate for the task. Do not stand under the equipment being lifted and moved.

# Diffusion Pump Basics

Diffusion pumps are used where throughput for heavy gas loads is important. The diffusion pumps begin to work at approximately  $10^{-3}$  Torr after a mechanical backing pump has exhausted most of the air in the system.

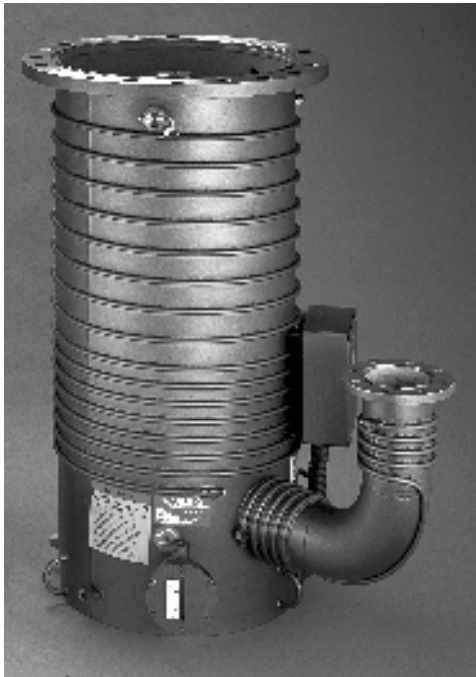

**Figure 1 HS-20 Diffusion Pump**

There are no moving parts in a diffusion pump, the heart of which is the multistage jet assembly, a group of concentric cylinders that are capped to leave small openings through which vapor can be deflected down and out toward the pump walls. A cold cap, mounted on top of the jet assembly helps keep pump fluid vapor out of the evacuation chamber. The pumps are water-cooled.

The vacuum fluid heater is mounted at the bottom of the pump body. The pumps also have a fill and drain assembly, and thermal protection switches. The inlet is at the top, and the exhaust is through the foreline.

## Pump Operation

The diffusion pump works by heating the pump fluid to its boiling point. The vapors travel upward inside the jet assembly and are accelerated out and downward through the jet nozzles toward the cool outer walls of the pump, where the vapor condenses back into a fluid. As the vapor passes the inlet, it picks up elements of the gas to be exhausted and carries them to the ejector and out of the pump via the foreline. The pump's ability to reach low pressures is governed in part by the inlet size. The gas migrates by thermal motion and is captured and expelled, thus lowering the pressure in the evacuation vessel.

Large diffusion pumps achieve a vacuum using a five-stage jet assembly consisting of four diffusion stages and one ejector stage. The cold cap and body are water cooled. Optional stainless steel Quick Cool coils quickly suppress boiling by cooling the heater; they require an independently valved water supply.

## Operating Characteristics

The Operating Characteristics of the large diffusion pumps are given in Table 4 on page 12. The graphs in Figure 2 through Figure 5 on page 14 show air speed and throughput as a function of inlet pressure. The dimensions of the inlet flange that connects to the system to be evacuated are given in Table 6 on page 15 through Table 12 on page 18

### NOTE



*The data in Table 4 on page 12 refers to pumps charged with DC-704 diffusion pump fluid.*

Table 4 Operating Specifications

Specification	Units	HS-16, 8.1 kW	HS-16, 9.6 kW	HS-20	HS-32	NHS-35
Operating Range	Torr	$1.6 \times 10^{-3}$ to $<5 \times 10^{-8}$	$2.0 \times 10^{-3}$ to $<5 \times 10^{-8}$	$1.3 \times 10^{-3}$ to $<5 \times 10^{-8}$	$1.7 \times 10^{-3}$ to $<5 \times 10^{-8}$	$9.0 \times 10^{-4}$ to $<5 \times 10^{-8}$
	mbar	$2.1 \times 10^{-3}$ to $<7 \times 10^{-8}$	$2.7 \times 10^{-3}$ to $<7 \times 10^{-8}$	$1.7 \times 10^{-3}$ to $<6.7 \times 10^{-8}$	$2.3 \times 10^{-3}$ to $<7 \times 10^{-8}$	$1.2 \times 10^{-3}$ to $<7 \times 10^{-8}$
Pumping Speed, ISO Standard 1608/1 *	l/s, Air	6000		10,000	17,300	28,000
	l/s, Helium	7500		12,500	21,265	35,000
Throughput (Air), Max.						
Optimum Range	Torr-l/s	9.5	12.0	12.5	30.0	25.0
	mbar-l/s	12.7	16.0	16.7	40.0	33.0
Overload Range (@ $1 \times 10^{-2}$ Torr)	Torr-l/s	11.5	13.5	18.0	35.0	35.0
	mbar-l/s	15.3	18.0	23.0	45.0	45.0
<p><b>CAUTION</b>  Extended operation of pumps in the <i>Overload</i> condition may result in breakdown of the top jet and resultant fluid loss through the foreline.</p>						
Forepressure, Max.	Torr					
				0.65	0.65	0.50
No Load	mbar			0.86	0.66	0.73
Full Load	Torr			0.55	0.35	0.40
				0.73	0.46	0.53
Backstreaming Rate at Pump Inlet (within Optimum Operating Range)	mg/cm <sup>2</sup> /min	<0.0015		<0.0015	<0.0007	<0.0005
Electrical Power AC, 50/60 Hz, 3 phase	kW	8.1	9.6	12	24	24
Cooling Water Flowrate @ Inlet Temperature of 60 to 80 °F	gpm (US)	1.5 Body and Cold Cap		1.5 Body and Cold Cap	Body 4.0 Cold Cap 1.5	Body 4.0 Cold Cap 1.5
* For the AVS pumping speed results, see the Agilent Vacuum Products catalog.						

**Table 4 Operating Specifications (Continued)**

Specification	Units	HS-16, 8.1 kW	HS-16, 9.6 kW	HS-20	HS-32	NHS-35
Warmup Time	minutes	30		45	60	60
Cooldown Time Without Quick Cool With Quick Cool	minutes	48		85	180	180
		30		45	60	60
Fluid Charge	qt (US)	3		5	12	12
	liters	2.8		4.7	11.4	11.4
Recommended backing pump capacity**	cfm	80		100	300	300
	**Recommended sizes when operating at maximum throughput.					
Weight	lbs (kg)	500 (227)		600 (272)	1350 (612)	1500 (682)
Jet Assembly		5-stage Aluminum	5-stage Aluminum	5-stage Stainless Steel	5-stage Stainless Steel	5-stage Stainless Steel
Materials		Body, Flanges, M/S-foreline baffle S/S Body, Cooling coils, Copper Cod cap, Nickel plated copper			Body, Flanges, M/S Body, Cooling coils, Copper Cod cap, Nickel plated copper	Body, Flanges, Foreline baffle M/S Body, Cooling coils, Copper Cod cap, Nickel plated copper
Thermal Switches		Upper (water) auto reset 185 ° F (85 °C) Lower (boiler) auto reset 390 °F (199 °C)			Upper (water) auto reset 220 ° F (104 °C) Lower (boiler) auto reset 550 °F (288 °C)	Upper (water) auto reset 200 ° F (93 °C) Lower (boiler) auto reset 600 °F (316 °C)
Water Connections		1/4" FPT			3/8" FPT	
Environmental	Maximum ambient temperature 113 °F (45 °C)					
Installation	Indoor use, Installation Category 2, Pollution Degree 2					
Altitude	6562' (2000 m)					

## Pump Air Speed and Throughput

The pumping function is graphically described by relating *inlet pressure* to both *air speed* and *throughput*. This relationship is shown for the large vacuum pumps in the set of graphs shown in Figure 2 through Figure 5.

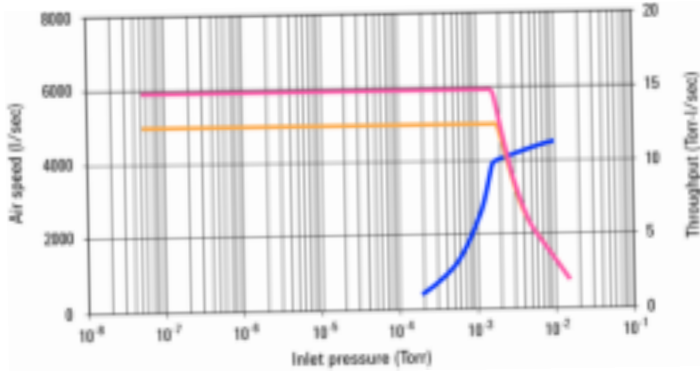

Figure 2 HS-16 Speed and Throughput Curves, 8.1 kW

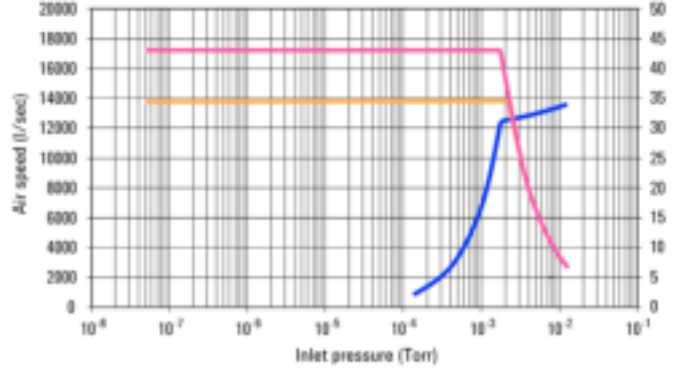

Figure 4 HS-32 Speed and Throughput Curves

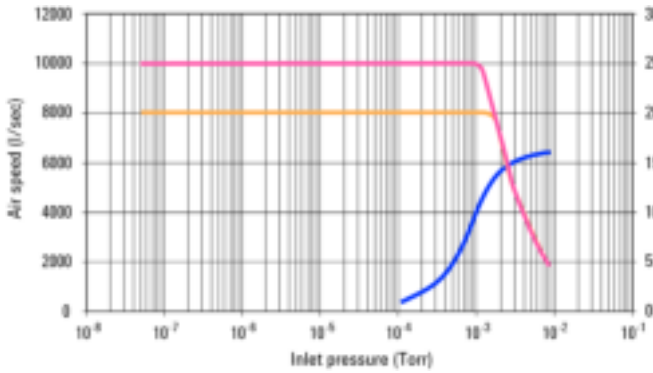

Figure 3 HS-20 Speed and Throughput Curves

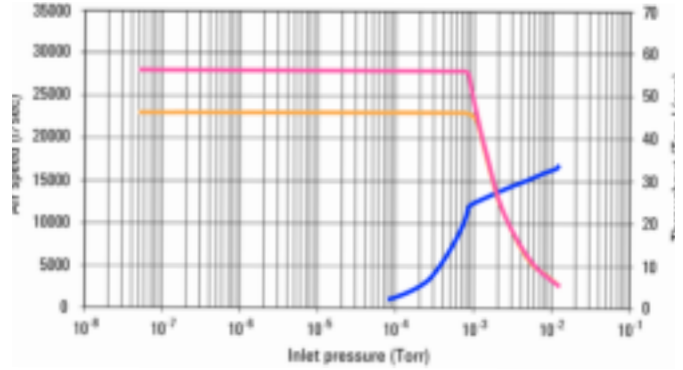
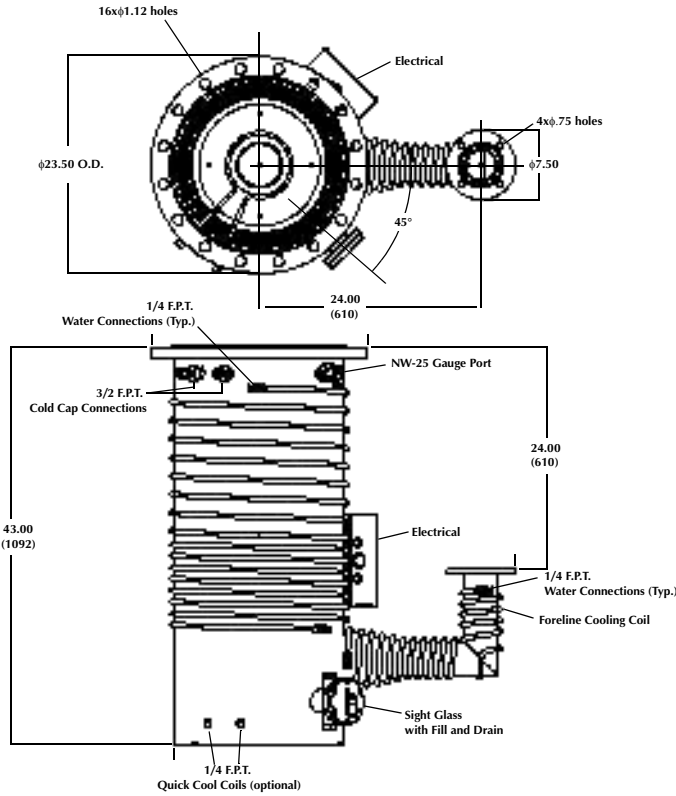

Figure 5 NHS-35 Speed and Throughput Curves

# High Throughput Diffusion Pumps

## Physical Specifications



**Table 5: HS-16: Dimensions and Weights**

	Units	HS-16
Height, minimum including clearance for heater access	in (mm)	51 (1295.4)
Weight	lbs (kg)	500 (227)
Connections: Body and Foreline	in	1/4 FPT
Quick Cool coils	in	1/4 FPT

**Figure 6 HS-16 Outline with ASA Flanges**

**Table 6 HS-16 Flange Dimensions**

		ASA		ISO	
Units		Inlet	Foreline	Inlet, 500 K	Foreline, 100 K
OD	in (mm)	23.50 (596.9)	7.50 (190.5)	21.65 (549.9)	5.12 (130.1)
ID	in (mm)	18.00 (457.2)	3.58 (90.9)	18.00 (457.2)	3.58 (90.9)
Thickness	in (mm)	1.00 (25.4)	0.50 (12.7)	0.67 (17.0)	0.47 (11.9)
Bolt Circle	in (mm)	21.25 (539.8)	6.00 (152.4)		
No. of Holes		16	4		
Size of Holes	in (mm)	1.13 (28.7)	0.75 (19.1)		
Orientation	Holes straddle center line of foreline				
Gasket Groove	ID	in (mm)	18.69 (474.7)	4.31 (109.5)	Requires NW-500 Centering Ring (not included with pump)
	Width	in (mm)	0.37 (9.4)	0.30 (7.6)	
	Depth	in (mm)	0.18 (4.6)	0.14 (3.6)	
					Requires NW-100 Centering Ring (not included with pump)

# High Throughput Diffusion Pumps

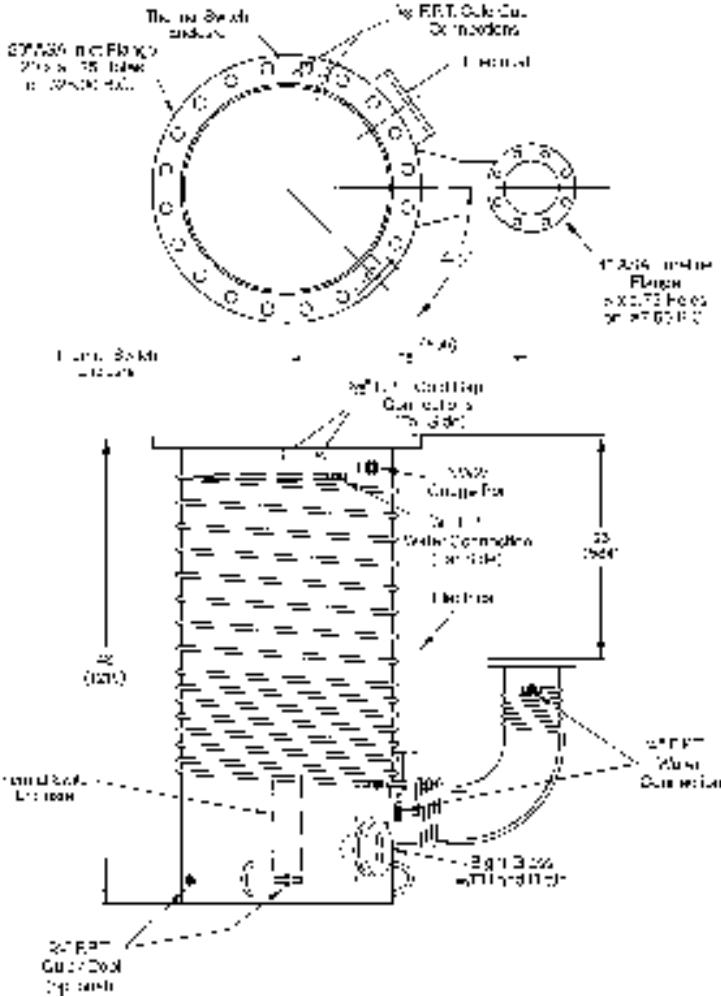

**Table 7 HS-20: Dimensions and Weights**

	Units	HS-20
Height, minimum including clearance for heater access	in (mm)	56 (1422)
Weight	lbs (kg)	600 (272.2)
Connections: Body and Foreline Quick Cool coils	in in	1/4 FPT 3/8 FPT

**Figure 7 HS-20 Outline with ASA Flanges**

**Table 8 HS-20 Flange Dimensions**

		ASA		ISO	
Units		Inlet	Foreline	Inlet, 630 K	Foreline, 160 K
OD	in (mm)	27.50 (698.5)	9.00 (228.6)	27.17 (690.1)	7.09 (180.1)
ID	in (mm)	21.25 (539.8)	5.06 (128.5)	21.25 (539.8)	5.06 (128.5)
Thickness	in (mm)	1.12 (28.5)	0.75 (19.1)	0.78 (19.8)	0.47 (11.9)
Bolt Circle	in (mm)	25.00 (635.0)	7.50 (190.5)		
No. of Holes		20	8		
Size of Holes	in (mm)	1.25 (31.8)	0.75 (19.1)		
Orientation	Holes straddle center line of foreline				
Gasket Groove	ID	in (mm)	21.63 (549.4)	5.31 (134.9)	Requires NW-630 Centering Ring (not included with pump)
	Width	in (mm)	0.48 (12.2)	0.38 (9.7)	
	Depth	in (mm)	0.25 (6.6)	0.09 (2.3)	



# High Throughput Diffusion Pumps

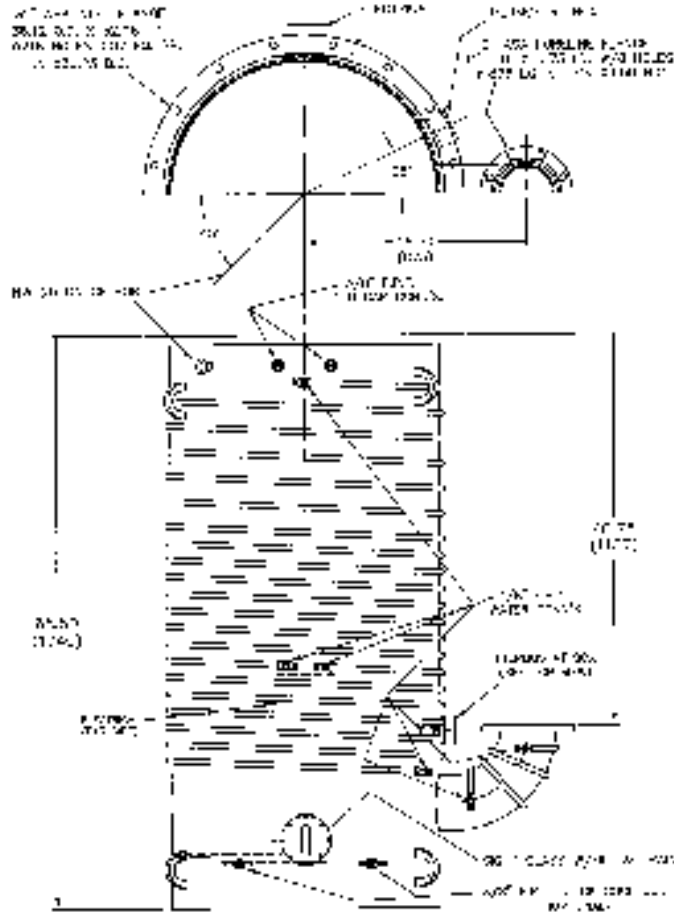

**Table 9 HS-32: Dimensions and Weights**

	Units	HS-32
Height, minimum including clearance for heater access	in (mm)	74 (1879.6)
Weight	lbs (kg)	1500 (680.4)
Connections:		
Body and Foreline	in	3/8 FPT
Quick Cool coils	in	3/8 FPT

**Figure 8 HS-32 Outline with ASA Flanges**

**Table 10 HS-32 Flange Dimensions**

		ASA		ISO		
Units		Inlet	Foreline	Inlet, 800 F	Forline, 200 K	
OD	in (mm)	38.12 (968.3)	11.00 (279.4)	36.22 (920.0)	9.45 (240.0)	
ID	in (mm)	32.06 (814.3)	6.73 (170.9)	32.06 (814.3)	6.73 (170.9)	
Thickness	in (mm)	1.12 (28.5)	0.75 (19.1)	1.12 (28.5)	0.47 (11.9)	
Bolt Circle	in (mm)	36.25 (920.8)	9.50 (241.3)	35.04 (890.0)		
No. of Holes		16	8	24		
Size of Holes	in (mm)	0.87 (22.1)	0.88 (22.4)	0.55 (14.0)		
Orientation	Holes straddle center line of foreline					
Gasket Groove	ID	in (mm)	32.5 (825.5)	7.44 (189.0)	32.75 (831.9)	Requires NW-200 Centering Ring (not included with pump)
	Width	in (mm)	0.56 (14.2)	0.38 (9.7)	0.56 (14.2)	
	Depth	in (mm)	0.25 (6.4)	0.18 (4.6)	0.25 (6.35)	

# High Throughput Diffusion Pumps

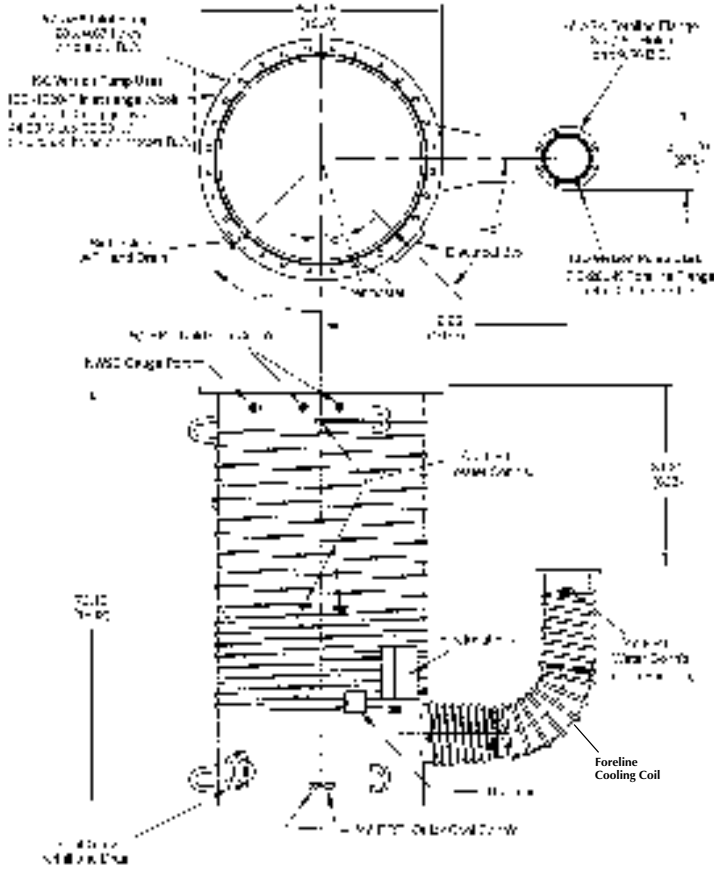

**Table 11 NHS-35: Dimensions and Weights**

	Units	NHS-35
Height, minimum including clearance for heater access	in (mm)	80 (2032)
Weight	lbs (kg)	1500 (680.4)
Connections:		
Body and Foreline	in	3/8 FPT
Quick Cool coils	in	3/8 FPT

**Figure 9 NHS-35 Outline with ASA Flanges**

**Table 12 NHS-35 Flange Dimensions**

		ASA		ISO		
Units		Inlet	Foreline	Inlet, 1000 F	Foreline, 200 K	
OD	in (mm)	41.75 (1060.5)	11.00 (279.4)	44.09 (1119.9)	9.45 (240.0)	
ID	in (mm)	35.00 (889.0)	7.72 (196.1)	35.00 (889.0)	7.72 (196.1)	
Thickness	in (mm)	1.12 (28.5)	0.75 (19.1)	1.12 (28.5)	0.47 (12.0)	
Bolt Circle	in (mm)	38.50 (977.9)	9.50 (241.3)	42.90 (1089.7)		
No. of Holes		28	8	32		
Size of Holes	in (mm)	0.87 (22.1)	0.81 (20.6)	0.55 (14.0)		
Orientation	Holes straddles center line of foreline					
Gasket Groove	ID	in (mm)	35.37 (898.4)	8.20 (208.3)	40.75 (1035.1)	Requires NW-200 Centering Ring (not included with pump)
	Width	in (mm)	0.56 (14.2)	0.17 (4.3)	0.56 (14.2)	
	Depth	in (mm)	0.25 (6.4)	0.09 (2.3)	0.25 (6.4)	

### Unpacking

#### WARNINGS



- ❑ *Before lifting a pump, check the weight of the equipment in Table 4 on page 12.*
- ❑ *Use power-assisted equipment, and trained moving and installation personnel to avoid dropping, slipping, and overturning the pump and severely injuring personnel.*
- ❑ *Do not stand under equipment being moved.*

Agilent large diffusion pumps are shipped in sturdy containers that permit prolonged storage in suitably protected areas without special precautions, however, care must be taken when moving the crated pump with a fork lift to avoid excessive shock.

Carefully remove the outer shipping container. Visually inspect the pump for damage that may have occurred during shipping and notify the carrier immediately if damage is suspected. If damage is noticed, save the crate and the internal packing for inspection.

### Setup

#### Assembly

1. Remove flange covers, blank plugs and protective plugs from water connections. Do not to scratch or otherwise damage the sealing surface (the O-ring groove on top of the inlet flange).
2. Check the internal jet assembly. It should be concentric and firmly seated on the bottom of the pump. Use a flashlight to verify that the ejector nozzle is opposite the foreline (the pump outlet connection). The jet assembly should not rotate; it is held by an indexing pin at the bottom of the assembly.
3. If the expected vacuum level is below  $10^{-7}$  Torr, clean the pump using the procedure outlined in the next section. Otherwise make sure that there are no foreign materials inside the pump, and proceed with attaching the pump to the system as instructed in “System and Utility Connections” on page 21.

## Cleaning a New Pump

### NOTE



A new pump requires cleaning only if the desired vacuum is below  $1 \times 10^{-7}$  Torr.

### Cleaning Safety

Cleaning a diffusion pump involves the use of acetone and alcohol, both of which are toxic and explosive. Take careful note of the following information and warnings before starting a cleaning process.

When heated, sprayed or exposed to high temperature equipment, these solvents become flammable and explosive, causing serious injury or death.

When heated or sprayed, acetone or alcohol also becomes 4 to 5 times heavier than air and flows down, settling in tanks, pits, and low areas, displacing air, and thus, can kill by asphyxiation.

Acetone, alcohol, and other solvents are irritants, narcotics, depressants, and carcinogenic. Their inhalation and ingestion may produce serious effects. Prolonged or continued contact with the skin will result in absorption through the skin and moderate toxicity.

### WARNINGS



- Do not use near a high temperature source.
- Always use in a large, well-ventilated room and ventilate the working area with a blower.
- Wear eyeshields, gloves, and other protective clothing. The use of a self-contained breathing apparatus may also be necessary.

## Disassembly for Initial Cleaning

This procedure involves the cleaning of the following elements:

- Jet assembly
- Drain plugs
- Sight glass
- Pump interior

To disassemble the pump:

1. Remove the cold cap as described in "Cold Cap" on page 43.
2. Disassemble the internal jet system from the body of the pump in accordance with the appropriate procedure within "Jet Assemblies" on page 44.
3. Remove fill and drain plugs and the sight glass with its O-ring and graphite gasket.

Set the O-ring aside as it must not be cleaned with a strong solvent. Alcohol, acetone, and other solvents degrade O-ring materials reducing their ability to hold a vacuum. If it is necessary to clean any O-rings, wipe with lint-free, clean cloth, wash in detergent and water, or use a small amount of pump fluid.

### CAUTION

Do not use any solvents on O-rings.



4. Thoroughly clean all components of the jet assembly and pump casing interior (but not O-rings) with acetone followed by an alcohol rinse.
5. Remove all traces of cleaning fluid by carefully drying all components with clean, dry, oil-free compressed air.

## Reassembly After Initial Cleaning

To reassemble the pump:

1. Perform disassembly steps 1 to 3 in reverse order, then continue with the following steps on a cleaned, reassembled pump.
2. Clean the interface and inlet flanges and O-ring grooves thoroughly with acetone or alcohol, using clean, lint free rags.
3. Remove all traces of acetone and alcohol by carefully drying all components, particularly the O-ring grooves, with clean, dry, oil-free compressed air.
4. Re-install the O-ring gasket.

## System and Utility Connections

### WARNING



Utility failure can cause overheating, damage to the equipment and explosion. Design your system to protect personnel and property from these hazards.

### Vacuum Connections

The pump body must be installed vertical and plumb. Check that the mating flange on the system is horizontal  $\pm 1^\circ$ . If this condition is not met, correct the system mount before installing the pump.

To make the vacuum system connection:

1. Wipe the O-ring seals with a clean cloth lightly moistened with diffusion pump fluid. Do not use solvents.
2. Install the O-ring in its groove. Be careful not to damage the sealing surface with cuts, nicks, or scratches.
3. Raise the pump using a lifting apparatus with sufficient capacity. Pump weights are given in Table 4 on page 12.
4. Align the bolt holes of the flanges and assemble the bolts.
5. Tighten the bolts evenly and compress the O-ring seal until light contact is achieved between the metal flanges.
6. Make a tightness check of the fill and drain plugs and the sight glass assembly. Refer to the appropriate outline drawings, Figure 6 on page 15 through Figure 9 on page 18. Apply light to medium torque, just enough to visually compress the gaskets.

### NOTE



Over time, minute leaks may develop through the gaskets. These leaks may only be detectable with extremely sensitive mass spectrometer leak detectors.

### Cooling Water

To connect cooling water HS-16/20:

1. Connect the cold cap cooling coil and all body and foreline cooling in series *except the Quick Cool coil (see the following paragraph)* as shown in Figure 10. Refer to Table 4 on page 12 for the cooling water flowrate for your pump type. Higher flows will not harm the pump.
2. If the diffusion pump is being cooled by a recirculating water system, ensure the system is capable of:
  - Adequate cooling and heat exchange to ensure a continuous inlet temperature of 60 to 80 °F (16 to 27 °C).
  - Maintaining an adequate flow rate to ensure the exit water temperature does not exceed 130 °F (54 °C).

Parallel connections should be employed when the water pressure is low or if the discharge temperature routinely exceeds 130 °F.

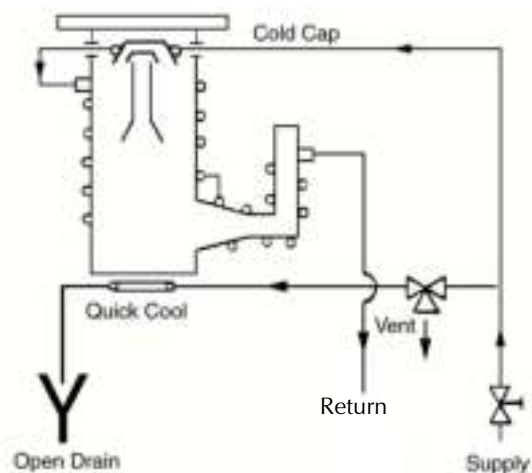

Figure 10 HS-16/20 Cooling Water Connections

## High Throughput Diffusion Pumps

To connect cooling water HS-32/NHS-35:

1. Connect all body and foreline cooling in series except the Quick Cool coil. Connect the Cold Cap cooling coil separately (Figure 11). Refer to Table 4 on page 12 for the cooling water flow rate. Higher flows will not harm the pump.
2. If the diffusion pump is being cooled by a recirculating water system, ensure the system is capable of:
  - ❑ Adequate cooling and heat exchange to ensure a continuous inlet temperature of 60 to 80 °F (16 to 27 °C).
  - ❑ Maintaining an adequate flow rate to ensure the exit water temperature does not exceed 130 °F (54 °C).

Parallel connections should be employed when the water pressure is low or if the discharge temperature from the pump body routinely exceeds 130 °F (54 °C).

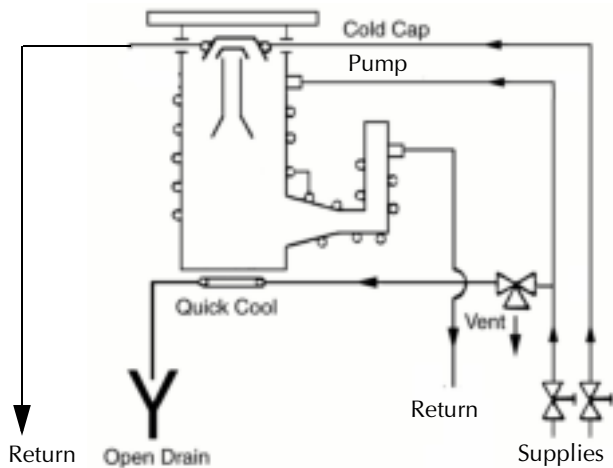

**Figure 11 HS-32/NHS-35 Cooling Water Connections**

### Quick Cool Coil Connection

The Quick Cool coil at the boiler plate must be connected to an open drain and the feed line must be controlled by a separate water 3-way valve: open, closed, and vented to the atmosphere. The drain must be below the boiler level so that it is drained completely when the Quick Cool coil water supply is shut off and the pump is operating.

## High Throughput Diffusion Pumps

---

### Obtaining High Vacuum on the NHS-35

When operating at low pressures (below  $1 \times 10^{-6}$  Torr), the ultimate pressure can be lowered by bypassing the portion of the cooling coils located at the bend of the foreline as shown in Figure 9 on page 18. This procedure raises the temperature of the foreline and provides additional degassing of the fluid returning to the boiler, thus making lower pressures possible.

#### NOTE



*This configuration decreases the maximum throughput capacity of the pump. Use this cooling configuration only if the pump is not meant to operate near the high pressure end of its operating range.*

# High Throughput Diffusion Pumps

## Electrical Connections

Terminal connections for each pump are different depending on the source voltage available, the principle difference being a Y or  $\Delta$  connection of the heaters. Table 13 provides the figure number and page of the wiring diagrams in this manual. The specific wiring diagrams for each pump shows both Y and  $\Delta$  connections and the source voltages for each connection.

**WARNING**



*Improper operation, severe heater damage, and danger to personnel can result from an improperly wired diffusion pump system.*

**WARNING**



*High voltages (up to 480 V) can kill. Always break the primary circuit to the pump before starting work on the heater or its wiring.*

**Table 13 Wiring Diagram Locations**

Source Voltage	HS-16 Wiring	HS-20 Wiring	HS-32 Wiring	NHS-35 Wiring
200 Delta		Figure 14 on page 28		
208 Delta	Figure 12 on page 26	Figure 14 on page 28		
220 Delta		Figure 14 on page 28	Figure 16 on page 30	Figure 19 on page 33
240 Delta	Figure 12 on page 26	Figure 14 on page 28	Figure 16 on page 30	Figure 19 on page 33
265 Delta		Figure 14 on page 28		
380 Delta	Figure 12 on page 26	Figure 14 on page 28		Figure 19 on page 33
380 Wye		Figure 15 on page 29		
400 Delta	Figure 12 on page 26	Figure 14 on page 28	Figure 16 on page 30	
415 Wye	Figure 13 on page 27	Figure 15 on page 29	Figure 17 on page 31	Figure 20 on page 34
430 Delta	Figure 12 on page 26	Figure 14 on page 28		
440 Delta	Figure 12 on page 26	Figure 14 on page 28	Figure 16 on page 30	
460 Delta	Figure 12 on page 26	Figure 14 on page 28		Figure 19 on page 33
480 Delta	Figure 12 on page 26	Figure 14 on page 28	Figure 18 on page 32	Figure 21 on page 35
575 Delta	Figure 12 on page 26	Figure 14 on page 28		

**CAUTION**



*Do not operate the pump at more than 5% over its rated voltage.*

*All electrical connections must be made by qualified personnel in accordance with all applicable laws and industrial codes.*

*For overcurrent protection, the pump must be installed with appropriate branch circuit protection.*

*To guarantee electrical safety, ensure the diffusion pump is bonded to the earth ground system.*



## High Throughput Diffusion Pumps

To wire the pump:

1. Check the heater for correct supply voltage and find the appropriate wiring diagram. The correct voltage is shown.
2. Check load balance by measuring the resistance of each branch. The heater resistances are given on their respective wiring diagrams.
3. Make the connections to the terminals in the electrical main junction box at the foreline shown in the appropriate outline drawing. Use flexible conduit to make it easier to remove the pump for service.
4. Connect the earth ground wire directly to the aluminum set screw ground lug.
5. Connect the input wires to the terminal block positions L1, L2 and L3(& N). For added safety, to prevent the wires from being disconnected, secure these wires together with the earth ground wire inside the junction box with a tie-wrap, similar to what has been done with the heater wires.
6. Wire the thermal switches to a control mechanism to ensure that power to the pump is shut off if one of the switches opens. The thermal switch wires can be found in the electrical box.
7. Complete the wiring of the pump and double-check that the proper terminal arrangement has been used for the source voltage at the site.

## Overheating: Detection by Thermal Switches

An overheat condition is detected by two normally closed thermal cutout switches, one of which monitors the boiler temperature while the other monitors the water temperature. These switches are set at the factory and *do not* require adjustment. The cutout temperatures for the water and boiler switches are given in Table 14.

**Table 14 Thermal Cutout Temperatures**

	Units	HS-16	HS-20	HS-32	NHS-35
Water Switch	°F	185	185	220	200
Boiler Switch	°F	390	390	550	600

Wire the pump such that if the contacts open on either the boiler or the water switch, power to the pump shuts off. If this happens during operation, check for one of the failure conditions listed below. When the problem has been corrected and the temperature lowered, the thermal switch automatically resets.

A rise in pump temperature can be caused by:

- Failure of cooling water flow
- High inlet pressure
- Low fluid level in the boiler

If you determine that the pump has not overheated and that the thermal switch has failed or drifted out of calibration, replace the switch with the device listed for your pump type in the appropriate Replacement Parts table, page 53 through page 56.

### CAUTION



*Thermal switches set to measure the temperature in the diffusion pump fluid are not designed to protect against overheating or backstreamed mechanical pump fluids.*

# High Throughput Diffusion Pumps

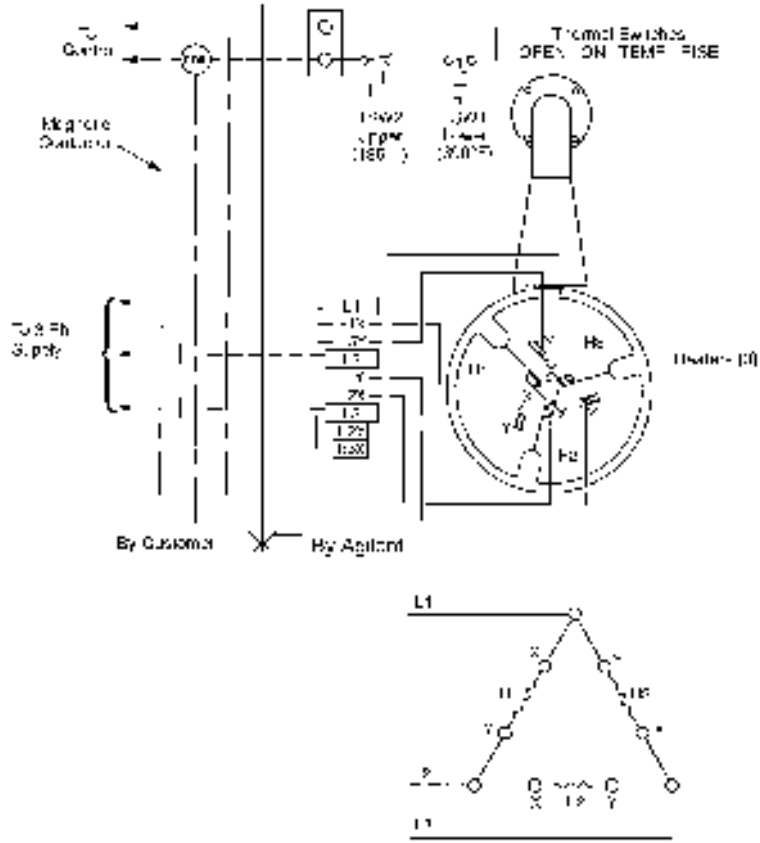

Figure 12 HS-16 3-Phase Delta Circuit

Table 15 HS -16 3 Phase Delta

NORMINAL HEATER RESISTANCE @ ROOM TEMPERATURE (OHMS)		LINE TO LINE RESISTANCE (OHMS) L1-L2/L2-L3/L3-L1		LINE CURRENT (AMPS)	
2700 W	3200 W	8100 WATTS	9600 WATTS	8100 WATTS	9600 WATTS
N/A	208 V = 12.8	N/A	208 V = 8.6	N/A	26.6
240 V = 20.3	240 V = 17.1	240V = 13.5	240 V = 11.4	19.5	23.1
380 V = 50.1	380 V = 45.1	380 V = 33.9	380 V = 28.6	12.3	14.6
400 V = 56.3	400 V = 47.5	400 V = 37.5	400 V = 31.7	11.7	13.9
430 V = 65.1	N/A	430 V = 43.4	N/A	10.9	N/A
440 V = 68.1	440 V = 57.5	440 V = 45.4	440 V = 38.3	10.6	12.6
460 V = 74.5	N/A	460 V = 49.6	N/A	10.2	N/A
480 V = 81.1	480 V = 68.4	480 V = 54.0	480 V = 45.6	9.7	11.6
N/A	575 V = 98.2	N/A	575 V = 65.4	N/A	9.6

# High Throughput Diffusion Pumps

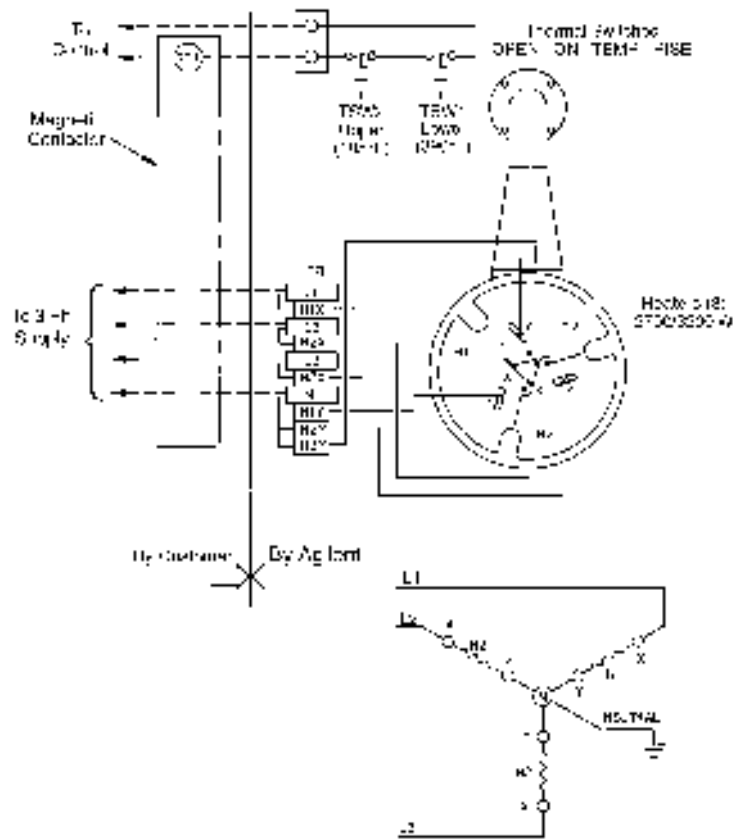
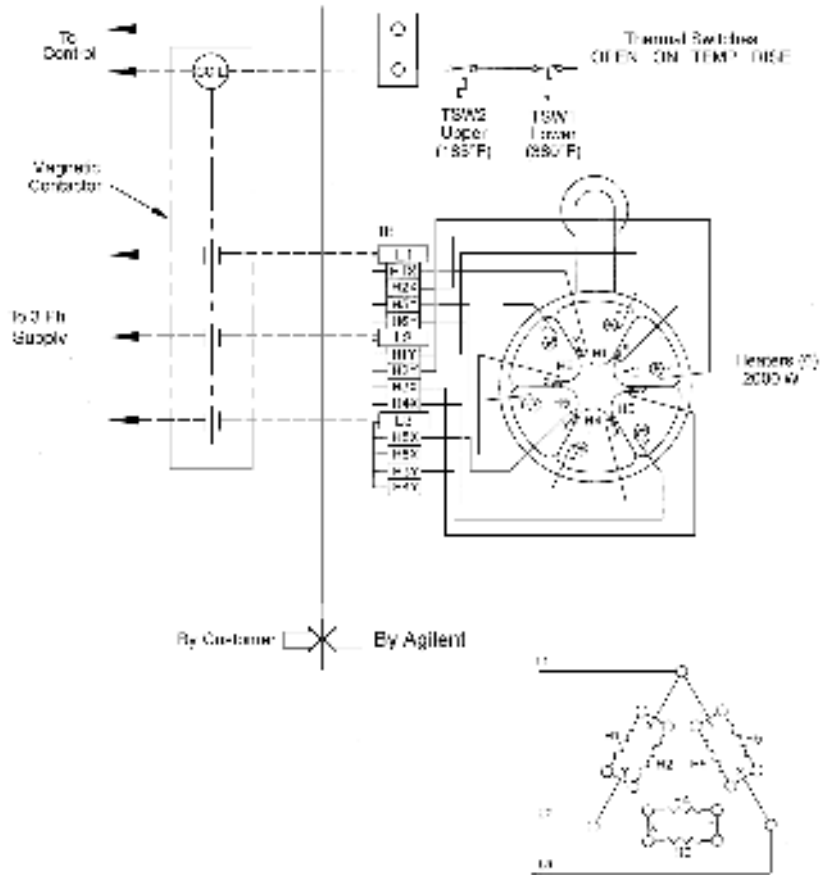

Figure 13 HS-16 3-Phase WYE Circuit

Table 16 HS -16 3 Phase WYE

NORMINAL HEATER RESISTANCE @ ROOM TEMPERATURE (OHMS)		LINE TO LINE RESISTANCE (OHMS) L1-L2/L2-L3/L3-L1		LINE CURRENT (AMPS)	
2700 W	3200 W	8100 WATTS	9600 WATTS	8100 WATTS	9600 WATTS
240 V = 20.3	240 V = 17.1	415 V = 40.4	415 V = 34.1	11.3	13.4

# High Throughput Diffusion Pumps



**Figure 14 HS-20 3-Phase Delta Parallel Circuit**

**Table 17 HS -20 3-Phase Delta Parallel**

NORMAL HEATER RESISTANCE @ ROOM TEMPERATURE (OHMS)	LINE TO LINE RESISTANCE (OHMS) L1-L2/L2-L3/L3-L1	LINE CURRENT (AMPS)
<b>2000 W</b>	<b>12000 Watts</b>	<b>12000 Watts</b>
200 V = 19	200 V = 6.3	34.6
208 V = 20.5	208 V = 6.8	33.3
220 V = 22.9	220 V = 8.1	31.5
240 V = 27.3	240 V = 9.1	28.9
265 V = 33.3	265 V = 11.1	26.1
380 V = 68.5	380 V = 22.8	18.2
400 V = 75.8	400 V = 25.3	17.3
420 V = 83.6	420 V = 27.8	16.5
430 V = 87.6	430 V = 29.2	16.1
440 V = 91.8	440 V = 30.6	15.8
460 V = 100.3	460 V = 33.4	15.1
480 V = 109.2	480 V = 36.4	14.4
575 V = 156.7	575 V = 52.2	12.1

# High Throughput Diffusion Pumps

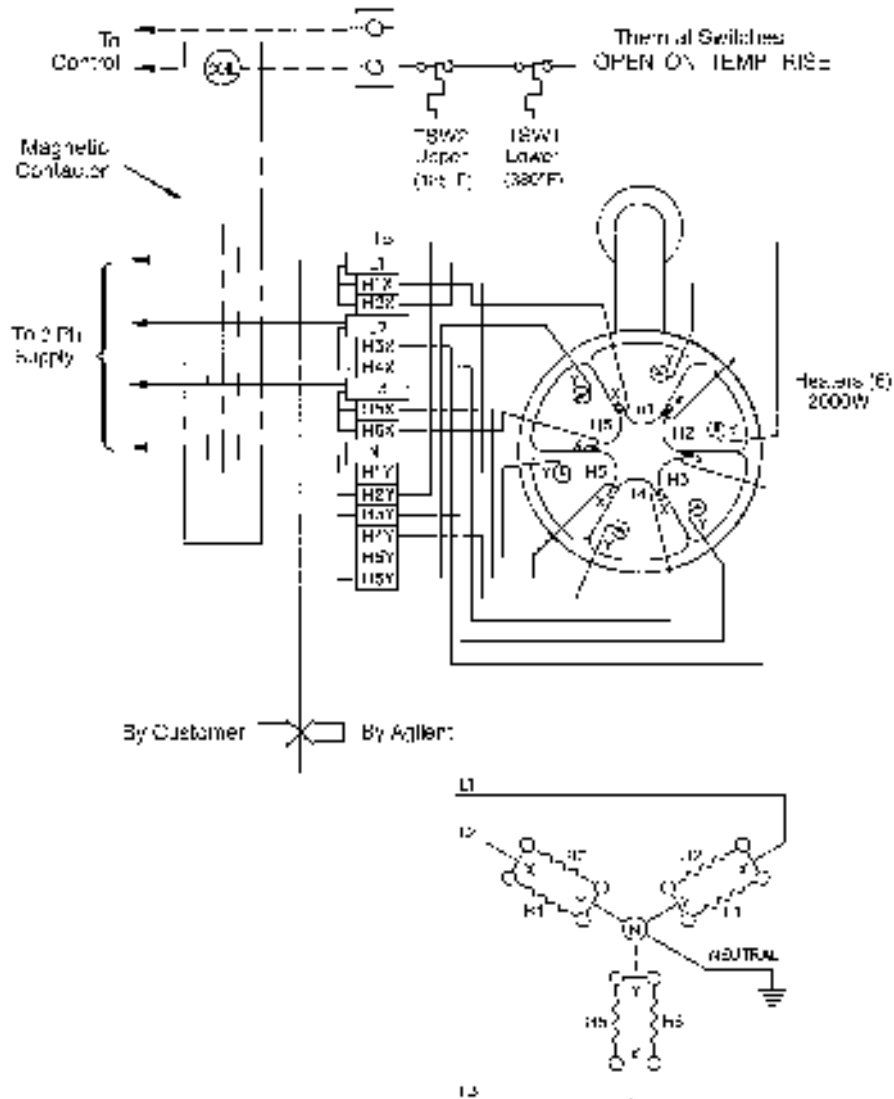
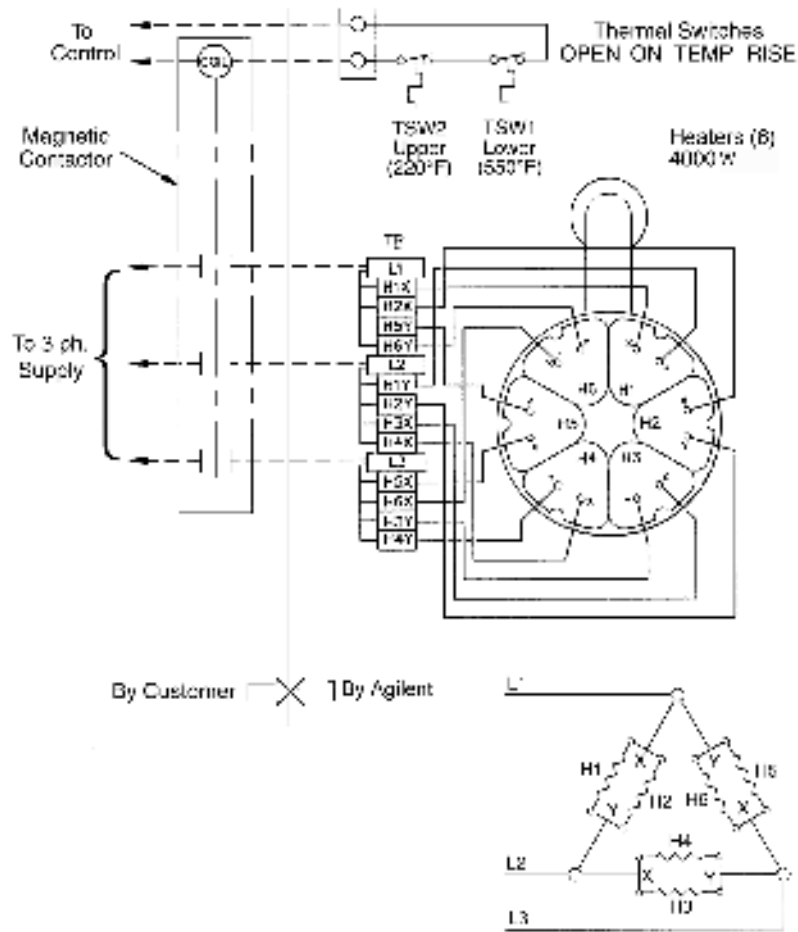

Figure 15 HS-20 3-Phase WYE Parallel Circuit

Table 18 HS -20 3-Phase WYE Parallel

NORMAL HEATER RESISTANCE @ ROOM TEMPERATURE (OHMS)	LINE TO LINE RESISTANCE (OHMS) L1-L2/L2-L3/L3-L1	LINE CURRENT (AMPS)
2000 W	12000 Watts	12000 Watts
220 V = 22.9	380 V = 22.8	18.2
240 V = 27.3	415 V = 27.2	16.7

# High Throughput Diffusion Pumps



**Figure 16 HS-32 3-Phase Delta Parallel Circuit**

**Table 19 HS -32 3-Phase Delta Parallel**

NORMINAL HEATER RESISTANCE @ ROOM TEMPERATURE (OHMS)	LINE TO LINE RESISTANCE (OHMS) L1-L2/L2-L3/L3-L1	LINE CURRENT (AMPS)
<b>4000 W</b>	<b>24000 Watts</b>	<b>24000 Watts</b>
220 V = 11.5	220 V = 3.8	63
240 V = 13.7	240 V = 4.5	57.7
400 V = 37.9	400 V = 12.6	34.6
440 V = 45.9	440 V = 15.3	31.5
	480 V = 18.2	28.9

# High Throughput Diffusion Pumps

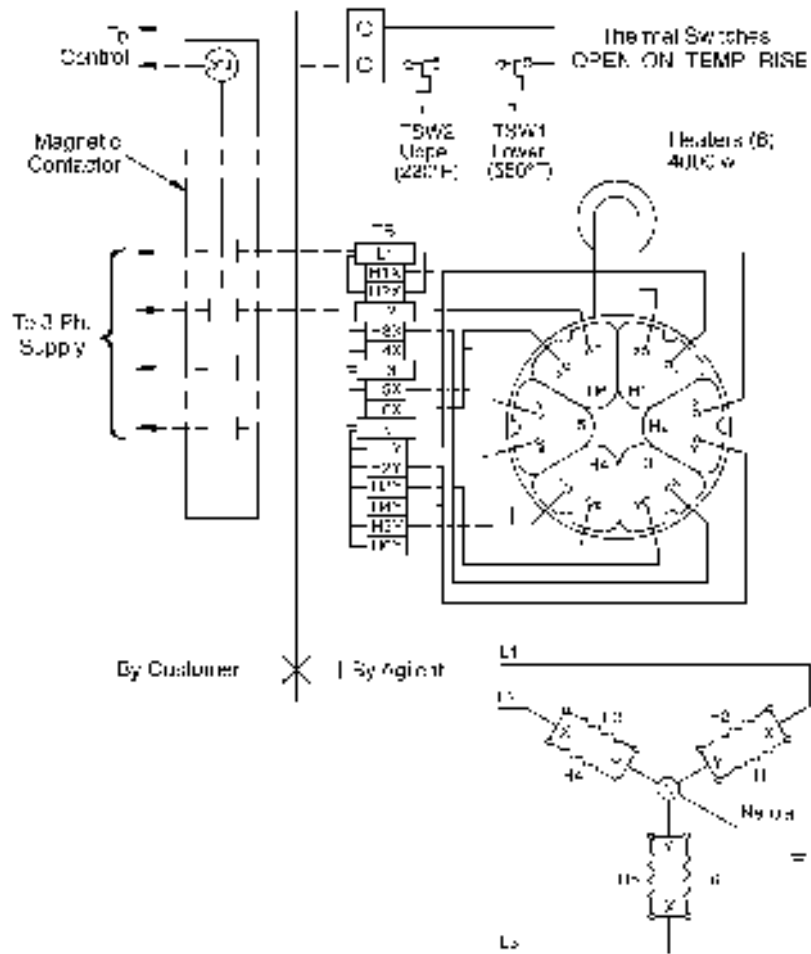

Figure 17 HS-32 3-Phase WYE Parallel Circuit

Table 20 HS -32 3-Phase WYE Parallel

NORMINAL HEATER RESISTANCE @ ROOM TEMPERATURE (OHMS)	LINE TO LINE RESISTANCE (OHMS) L1-L2/L2-L3/L3-L1	LINE CURRENT (AMPS)
4000 W	24000 Watts	24000 Watts
240 V = 13.7	415 V = 13.6	33.4

# High Throughput Diffusion Pumps

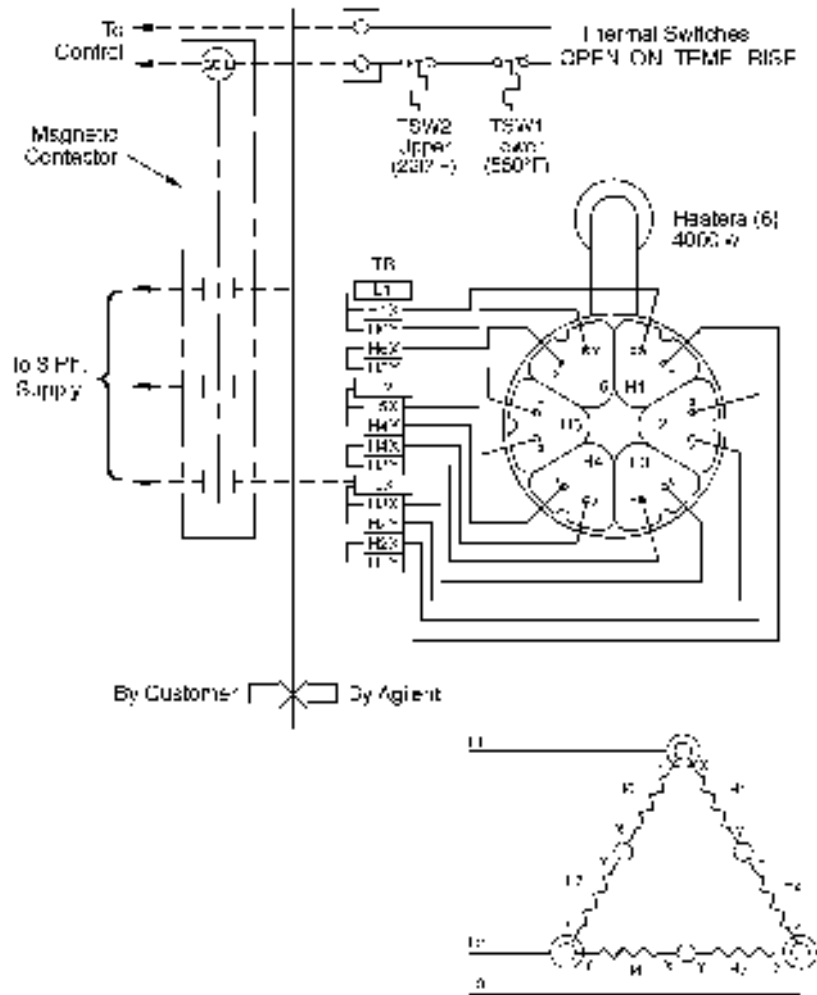

Figure 18 HS-32 3-Phase Delta Series Circuit

Table 21 HS -32 3-Phase Delta Series

NORMINAL HEATER RESISTANCE @ ROOM TEMPERATURE (OHMS)	LINE TO LINE RESISTANCE (OHMS) L1-L2/L2-L3/L3-L1	LINE CURRENT (AMPS)
4000 W	24000 Watts	24000 Watts
240 V = 13.7	480 V = 18.2	28.9



# High Throughput Diffusion Pumps

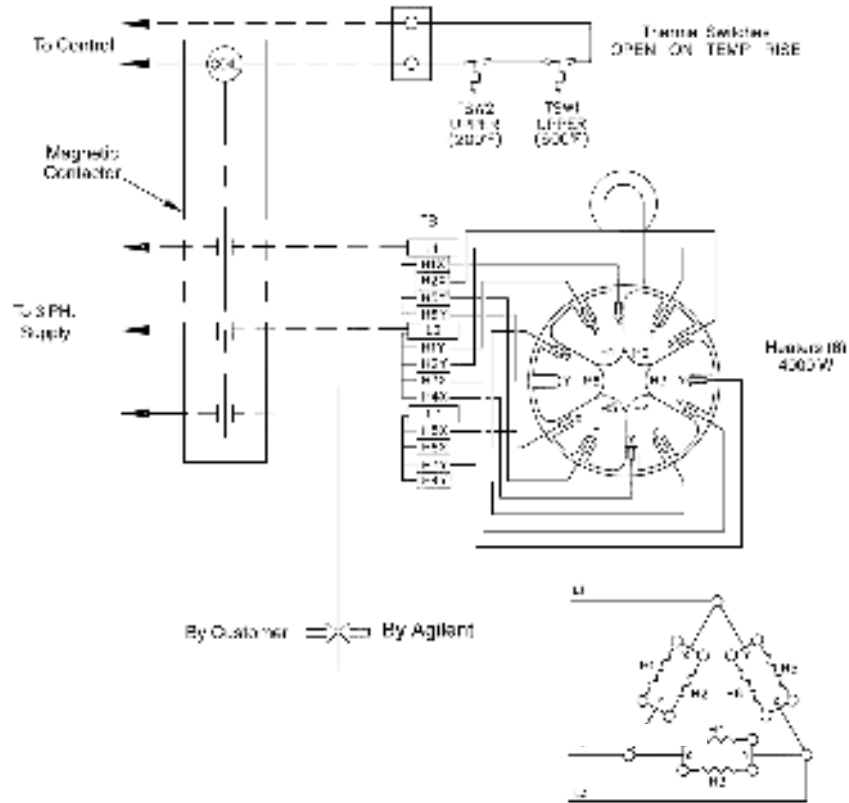

Figure 19 NHS-35 3-Phase Delta Parallel Circuit

Table 22 NHS-35 3-Phase Delta Parallel

NORMINAL HEATER RESISTANCE @ ROOM TEMPERATURE (OHMS)	LINE TO LINE RESISTANCE (OHMS) L1-L2/L2-L3/L3-L1	LINE CURRENT (AMPS)
<b>4000 W</b>	<b>24000 Watts</b>	<b>24000 Watts</b>
220 V = 11.5	220 V = 3.8	63
240 V = 13.7	240 V = 4.5	57.7
380 V = 34.2	380 V = 11.4	36.5
460 V = 37.9	460 V = 16.8	30.1
	480 V = 18.2	28.9

# High Throughput Diffusion Pumps

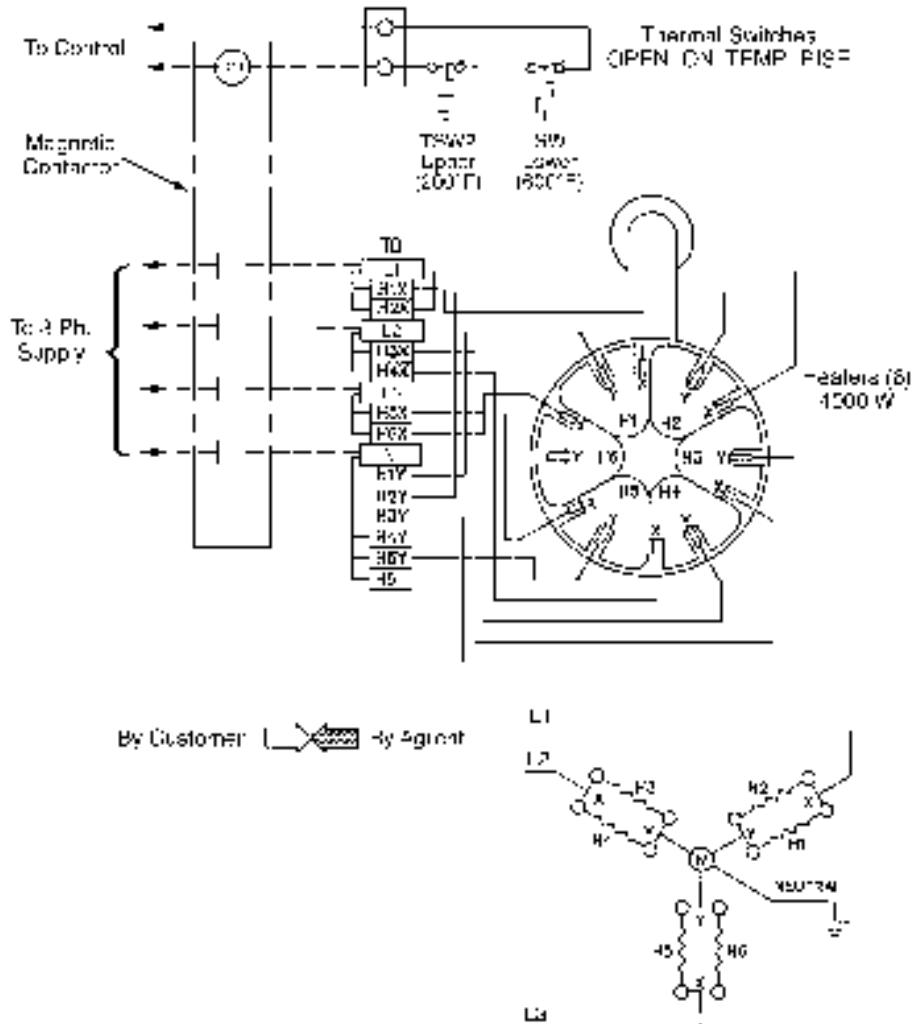

Figure 20 NHS-35 3-Phase WYE Parallel Circuit

Table 23 NHS-35 3-Phase WYE Parallel

NORMINAL HEATER RESISTANCE @ ROOM TEMPERATURE (OHMS)	LINE TO LINE RESISTANCE (OHMS) L1-L2/L2-L3/L3-L1	LINE CURRENT (AMPS)
4000 W	24000 Watts	24000 Watts
240 V = 13.7	415 V = 13.6	33.4

# High Throughput Diffusion Pumps

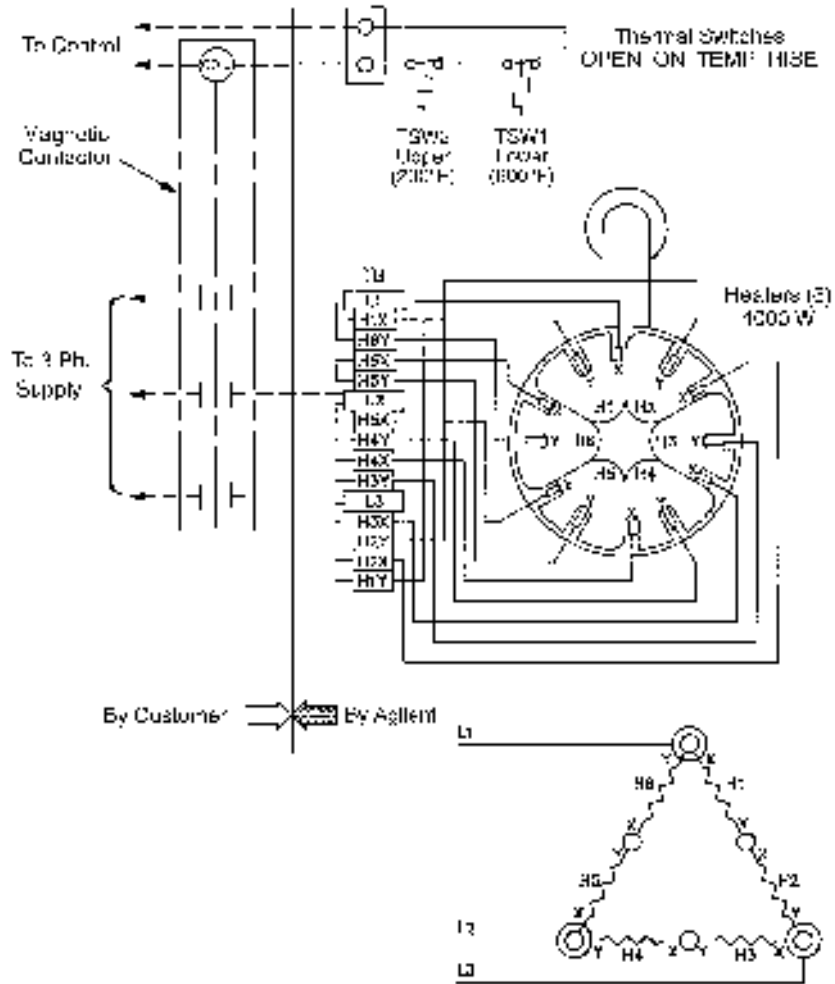

Figure 21 NHS-35 3-Phase Delta Series Circuit

Table 24 NHS-35 3-Phase Delta Series

NORMAL HEATER RESISTANCE @ ROOM TEMPERATURE (OHMS)	LINE TO LINE RESISTANCE (OHMS) L1-L2/L2-L3/L3-L1	LINE CURRENT (AMPS)
4000 W	24000 Watts	24000 Watts
240 V = 13.7	480 V = 18.2	28.9

# Initial Vacuum Test

Before charging the pump with fluid, carry out this initial vacuum test to establish the tightness of the system and its vacuum connections.

Pumps and their components are designed for vacuum service; they are not designed to be pressurized which could cause them to burst possibly expelling shrapnel at lethal velocities. Serious accidents have been caused by intentional pressurization of vacuum systems and their components.

### WARNINGS



- ❑ Never pressurize any part of a vacuum system for test or any other purpose.
- ❑ Always provide pressure relief when designing diffusion pumps into systems and ensure that pressure relief motion is limited to safe envelopes.

To perform the initial vacuum test:

1. Confirm the vacuum ultimate pressure characteristics of the fore pump. This should closely approximate the value quoted in the manufacturer's data, if the mechanical pump is correctly installed, adjusted, and filled with clean fluid.
2. Measure pressure with a continuously indicating total pressure gauge, such as a capacitance manometer, or thermocouple gauge.
3. Connect the outlet (or foreline) of the diffusion pump to the inlet of the fore pump using vacuum-tight connections.
4. The procedure varies for valved and unvalved systems.
  - ❑ For valved system: Close the roughing valve and main isolation valve ahead of the diffusion pump.
  - ❑ For unvalved systems: Include the entire work chamber volume in the test.
5. Evacuate the system using only the fore pump. Let the pump reach an ultimate pressure in the system. This reading should approximate the value obtained in step 2 above (usually 10 to 50 microns, 0.013 mbar to 0.067 mbar).
6. If the pump does not reach this level, examine the system for leakage following standard procedures for leak testing. These procedures depend on the type of vacuum gauges and leak detection equipment available.

### NOTE



Consult with your Agilent representative for information on Agilent's extensive line of helium leak detectors.

### Adding or Changing Pump Fluid

#### WARNINGS



*The risk of explosion on large vacuum diffusion pumps is increased by these factors:*

- ❑ *Use of a hydrocarbon fluid as the pumping fluid.  
Hydrocarbon fluid is more prone to explosion than synthetic silicone-based fluid. If a hydrocarbon fluid is being used, check the entire system under vacuum before operating the pump.*
- ❑ *Low fluid levels in the pump which can lead to overheating.  
Low fluid levels develop because the charge gradually depletes during use. The pump, however, continues to operate normally and when the charge drops to 60% of initial level, the boiler temperature may begin to rise. If this takes place, the thermal switches open the heater circuits. For details, refer to “Overheating: Detection by Thermal Switches” on page 25.*
- ❑ *Overheated pump fluid that decomposes and becomes toxic.  
The toxic fluid residue may be on the dipstick used to check fluid level, so care must always be taken to assure personnel do not contact or ingest the fluid.*
- ❑ *Admission of atmospheric air during pump operation.  
Leakage of air into the system allows oxygen into the fluid vapor and increases the risk of explosion. If holding a vacuum is difficult, perform a leak test. Do not use the pump until the leak source is located and repaired.*

The recommended fluid charge for each pump is given in Table 4 on page 12.

Fluids must be stored in clean, tightly closed containers and should be clearly identified in accordance with their type. Do not mix pumping fluids of different types and origins. Generally, it is not a good idea to mix used and new fluid for a pump charge.

#### CAUTION



*The use of Santovac<sup>®</sup> 5 Diffusion Pump Fluid is not recommended in these pumps, nor is the use of any hydrocarbon fluid.*

### Information on Fluid and DP Performance

The choice of fluid depends on the application. The most common type of fluid used in the market is a silicone based fluid, and all vacuum performance data in this manual was generated using a silicone based fluid called DC704. There are many fluids on the market that are equivalent to the DC704. The pump will operate with other types of oil, but the performance may be different. Since there are so many options, it is not possible to summarize and recommend them all.

## High Throughput Diffusion Pumps

To add or change pump fluid:

1. Locate the fill and drain fittings in the appropriate outline drawing. Refer to Figure 6 on page 15 through Figure 9 on page 18. The fittings have special Viton<sup>®</sup> elastomer sealed plugs.
2. Assure that the power to the heaters is off.

### CAUTION



*Wait until the pump has cooled then vent it to the atmosphere.*

3. Remove the drain plug and drain fluid into a suitable sized container.

### NOTE



*Dispose of fluids in accordance with all appropriate regulations.*

4. Remove the plug from the filling port of the pump and pour the fluid in up to the FULL COLD level on the sight glass as shown in Figure 22. The fluid can also be poured in from the pump inlet or foreline.

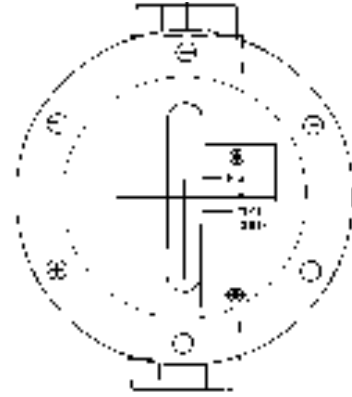

**Figure 22 Sight Glass Assembly**

5. Replace the fill plug with a new Viton gasket. Lubricate the O-ring with pump fluid, put the O-ring in place, and reassemble the system.
6. Tighten the fill plug using maximum torque of 75 inches-pounds.

Once the pump is running, check that the fluid level is at the FULL HOT level in the sight glass.

# Operation

During initial installation, the newly installed pump fluid may be subjected to degassing. This may result in foreline pressure fluctuations that are considered normal.

### WARNINGS



*The following conditions increase the risk of explosion:*

- Air leaks into the system*
- Roughing through a hot diffusion pump, which can cause hot hydrocarbon fluids to ignite or explode when exposed to air*
- Air release or the admission of air to a pump with a hot boiler (permitting a strong oxidizer to contact the hot pump fluid)*
- Pressure above 1 milli Torr ( $1.3 \times 10^{-3}$  mbar)*
- Insufficient (or low level of) pump fluid*
- Operating a pump without circulating cool water to the main body cooling coils*
- Operating pump with water trapped in Quick Cool coil*
- Foreign matter in the pumping fluid, which changes its viscosity and obstructs flow passages*

### CAUTIONS



- Do not turn on the heater without fluid in the pump. This may ruin the heaters and damage the pump.*
- Do not air-release the pump while the boiler is hot. Most diffusion pump fluids break down under these conditions.*
- Do not operate the pump heater unless cooling water is circulating. Doing so causes the pump and fluid to overheat.*
- Do not operate without a foreline baffle. This can cause a greater than normal fluid loss. \*The HS-32 does not have a foreline baffle.*

### Startup Procedure

To start the pump:

1. Evacuate the diffusion pump using a mechanical roughing pump to below 0.5 Torr (0.67 mbar). The diffusion pump will not function unless the discharge pressure is less than the tolerable forepressure.
2. Turn on the cooling water supply to the pump body and check that adequate flow is provided by examining the amount of water discharged at the visual drain points.

#### CAUTION



To prevent harmful collection of condensate on the boiler plate, heater, and heater terminals, do not operate the Quick Cool coil when the pump is cold or out of service.

3. Switch on the power to the diffusion pump heater.
4. Check inlet and forepressure performance by means of the system instrumentation.

### Humid Environments

Due to their inherent design, diffusion pump heaters absorb moisture. This results in a decrease in heater insulation resistance (higher leakage current). Under normal conditions, the decrease in insulation resistance is a momentary condition that occurs on startup. The amount of moisture adsorbed depends on the temperature, humidity, and the length of time the heaters have been exposed to this environment without power being applied. If diffusion pumps are started in high humidity environments, the heaters may be damaged on startup at full power. To overcome the effect of moisture absorbed in the heaters, start pumps at a low line voltage, e.g., 50% of line voltage, for a period or time to slowly expel any moisture.

### Shutdown Procedure

#### WARNING



1. Releasing or admitting air to a pump with a hot boiler, especially when it is under vacuum, permits a strong oxidizer to contact the hot pump fluid and greatly increases the risk of an explosion.
2. Boiler temperatures reach 530° F (275 °C) which can cause serious burns. Always check that surfaces have cooled to near room temperature before touching them.

To shut down the pump:

1. Close the inlet valve on the system, if equipped.
2. Turn off the power to the heaters.
3. For pumps equipped with the optional Quick Cool Coil, admit water into the coil.
4. Continue to flow cooling water through the pump (and Quick Cool Coil, if equipped) for at least the time period listed under "Cooldown Time Without Quick Cool With Quick Cool" in Table 4 on page 13.
5. Once the pump is cooled, shut off the mechanical backing pump.
6. Air release the pump.
7. Continue cooling water flow until the pump is at room temperature, then shut off the water supply.



# Maintenance

Perform these periodic checks to assure trouble-free operation. This maintenance prevents costly down-time and cleaning procedures. Maintain a day-to-day log of pump and system performance to identify marked variations that require corrective action.

## Periodic Inspections

The maximum interval between inspection of the pump is established on the basis of experience.

### WARNINGS



- ❑ *High voltages (up to 480 V) can kill. Always break the primary circuit to the power supply before starting work on the heater or its wiring.*
- ❑ *Avoid the possibility of serious burns by making sure that the pump is at room temperature before attempting service.*
- ❑ *Always wear appropriate gloves and clothing and use a self-contained breathing apparatus. Poisonous or corrosive compounds may be present when opening the fill or drain.*
- ❑ *Explosion risk is high if the fill or drain is opened when the pump is running or when it is hot.*

*To perform general maintenance, do the following:*

1. Check the condition and level of fluid when the pump is cold. Withdraw a sample through the drain and visually check the level of fluid through the sight glass. Slight discoloration of the fluid does not affect pump performance. Use new O-ring gaskets when replacing fill and drain plugs.

Loss of the fluid can be caused by:

- ❑ Admittance of excessive air or other gas to a hot pump
- ❑ Inadequate water cooling
- ❑ Continuous operation in the overload range as given in Table 4 on page 12
- ❑ Failure to reinsert the foreline baffle in the pump assembly

### NOTE



*The HS-32 does not have a foreline baffle.*

2. When the pump is cold, check that the heaters are bolted snugly to the boiler plate and that all heater terminal connections are fastened tightly inside the junction box.
3. Check the total heater power input and balance of the load.
4. Ensure that cooling water flow is unobstructed and that the flow rate does not fall not below quantities specified in Table 4 on page 12.

# Cleaning

## Cleaning Safety

Cleaning a diffusion pump involves the use of acetone and alcohol, both of which are toxic and explosive. Take careful note of the following warnings before starting a cleaning process.

When heated, sprayed or exposed to high temperature equipment, these solvents become flammable and explosive, causing serious injury or death.

When heated or sprayed, acetone or alcohol also becomes 4 to 5 times heavier than air and will flow down, settling in tanks, pits, and low areas, thus displacing air which can kill by asphyxiation.

Acetone, alcohol, and other solvents are irritants, narcotics, depressants, and carcinogenic. Their inhalation and ingestion may produce serious effects. Prolonged or continued contact with the skin will result in absorption through the skin and moderate toxicity.

### WARNINGS



- ❑ *Do not use near a high temperature source. Ventilate the working area with a blower and use in a large, well-ventilated room. The use of a self-contained breathing apparatus may also be necessary.*
- ❑ *Always ensure that cleaning operations are carried out in large, well-ventilated rooms. Wear eyeshields, gloves, and protective clothing.*

Complete cleaning of the pump may be required due to gradual deterioration of pump fluids. Removal of the pump from the system is then necessary.

*To clean an installed pump:*

1. Disconnect all water cooling lines and break the primary circuit supplying power to the pump heaters.
2. Unbolt the inlet and foreline connections and remove the pump from the system.
3. Drain the pump of all fluid.
4. Remove the cold cap as described in "Cold Cap" on page 43.
5. Remove the jet assembly as described for the specific pump model in "Jet Assemblies" on page 44.
6. Thoroughly clean the pump body interior using acetone followed by an isopropyl alcohol rinse and then dry the pump with clean, dry, oil-free compressed air.
7. Thoroughly clean the jet assembly using acetone. Wipe all surfaces with isopropyl alcohol, and dry with clean, dry, oil-free compressed air.
8. Reinstall the jet and cold cap in the pump body. Be sure that the ejector is properly aligned with the foreline.
9. Check the condition of the O-rings. Replace O-rings that show any sign of wear or compression.
10. Attach the pump in the system.

## Disassembly and Reassembly Procedures

### Cold Cap

To disassemble the cold cap, refer to Figure 23 and take the following steps.

**NOTE**



The halo baffle is disassembled in the same manner.

1. Remove the female coupling, nut, follower, and gasket located at the end of the cold cap water line on the outside of the pump.
2. Remove the cold cap securing screw which secures the cold cap to the jet assembly.
3. Lift out the cold cap.

To reassemble the cold cap:

1. Insert the end of the cold cap water line into the cold cap port opening at the side of the pump before setting the cold cap on top of the jet assembly. Be careful not to damage the sealing surfaces.
2. Replace the cold cap securing screw which secures the cold cap to the jet assembly. Do not overtighten the screw.
3. Replace the gasket, the follower, the nut, and the female coupling to the side of the pump.

**NOTE**



Supply water tubing must be connected to the cold cap coupling with FPT threads.

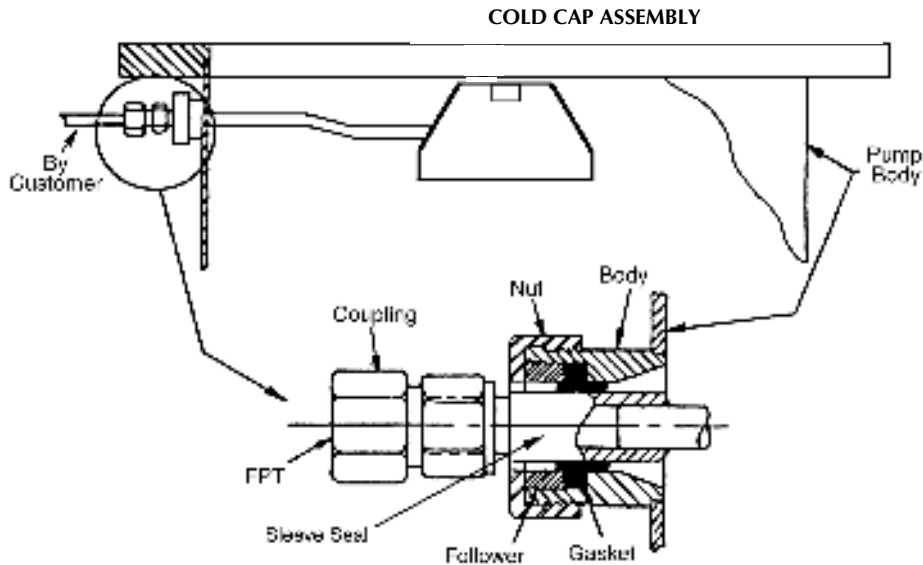

Figure 23 Cold Cap Assembly

## Jet Assemblies

The jet assemblies of each of the pumps are discussed and shown in the following subsections. Procedures and drawings are specific to each pump model.

### HS-16 Jet Assembly

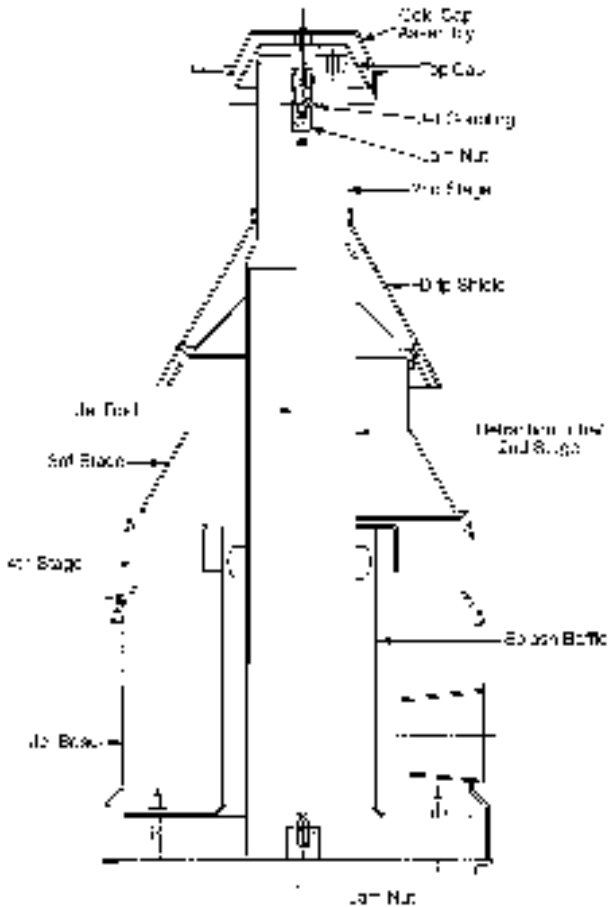

Figure 24 HS-16 Jet Assembly

To disassemble the jet assembly:

1. Remove the cold cap or halo baffle as described in "Cold Cap" on page 43.
2. Unscrew the top cap from its coupling and remove it.
3. Remove the top plug.
4. Remove the drip shield that sits loosely on the 2nd stage.
5. Lift and remove the entire 2nd stage.
6. Lift and individually remove the 3rd stage, the 4th stage, and the jet base.
7. Remove the two nuts securing the splash baffle, then lift and remove the splash baffle.
8. Remove the jam nut located at the center-bottom of the pump in order to remove the jet rod.

To assemble the jet assembly:

- Reverse the disassembly steps above.

**NOTE**



When the jet assembly is installed in the pump body, be sure that the slot in the jet base is engaged in the locating pin of the boiler. Unless this is done, the pump will not function properly.

**NOTE**



If the jet coupling loosens from the jet rod during disassembly, position it so that the top of the jet coupling is flush with the bottom orifice plug as can be seen in Figure 26.

# High Throughput Diffusion Pumps

## HS-20 Jet Assembly

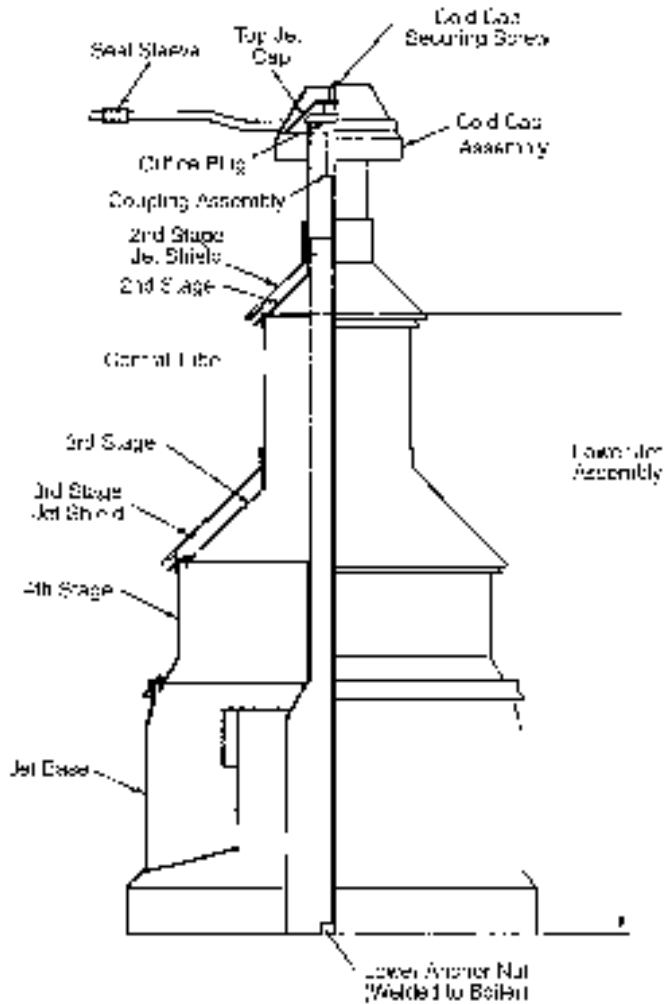

Figure 25 HS-20 Jet Assembly

To disassemble the jet assembly:

1. Remove the cold cap or halo baffle as described in "Cold Cap" on page 43.
2. Unscrew the jet cap from the coupling assembly.
3. Remove the orifice plug.
4. Withdraw the central tube complete with the second stage jet and jet shield.
5. Remove the lower jet assembly from the pump, which consists of the third stage jet, the jet shield, the fourth stage jet, and the jet base.
6. Remove the third stage shield from the lower jet assembly.

### NOTE



Before removing the securing screws in the following step, scribe a reference mark at the interface to assure that original holes are mated when reassembled.

7. Remove the securing screws between the third and fourth stage jets. Carefully preserve the screws. Be sure that the jet spacers are not damaged in handling.
8. Remove the fourth stage jet from the jet base.
9. Clean all parts thoroughly.

## High Throughput Diffusion Pumps

To reassemble the jet assembly:

1. Replace the fourth stage jet on the jet base.
2. Replace and tighten the securing screws between the fourth stage and the jet base uniformly and in a cyclical pattern.

**NOTE**

*Jet spacings are preset at the factory and controlled by the spacers secured to the respective stages.*



3. Replace the third stage jet on the fourth stage.
4. Replace and tighten the securing screws between the third stage and fourth stage uniformly and in a cyclical pattern.

5. Replace the third stage jet shield.
6. Install the lower jet assembly in the pump.
7. Check that the lower jet assembly is firmly seated on the pump with the ejector correctly positioned. For proper alignment, a pin is provided in the base of the pump; the large slot in the jet base must register on this pin.
8. Follow steps 1 through 5 in reverse order.

**NOTE**

*If the jet coupling loosens from the jet rod during disassembly, position it so that the top of the jet coupling is flush with the bottom orifice plug (Figure 26).*

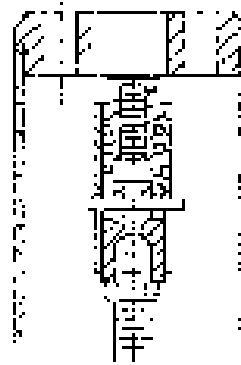
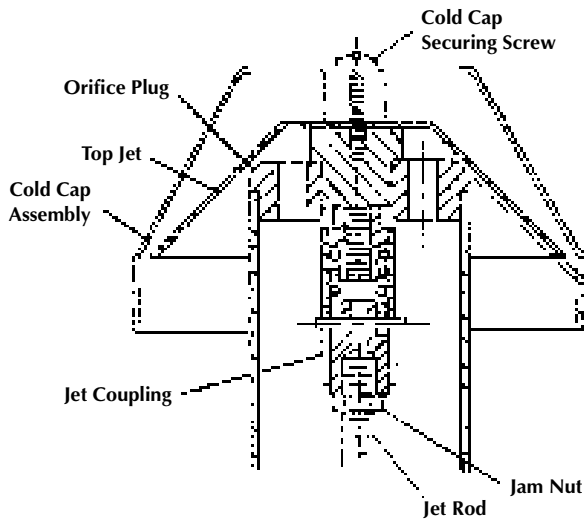

Detail A  
Location of Jet Coupling  
prior to assembling Jet Cap.

Figure 26 Jet Coupling Detail

## High Throughput Diffusion Pumps

### HS-32 Jet Assembly

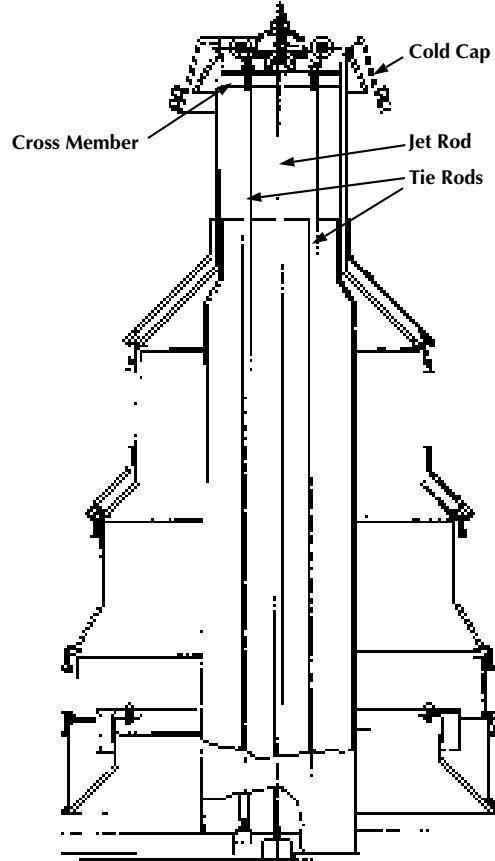

Figure 27 HS-32 Jet Assembly

*To disassemble the jet:*

1. Unscrew and remove the hex nut holding the cold cap in place. Note its orientation prior to removal
2. Remove the cold cap (or halo baffle) as described in "Cold Cap" on page 43.
3. Remove the nut, washer, and the top jet cap from the center jet rod.
4. Using the now-exposed cross member and the appropriate lifting equipment, lift the entire jet assembly out of the pump body, leaving the jet rod in place.
5. Remove the second stage jet shield.
6. Remove the two nuts on the cross member and lift out the second stage and fractionating tub, leaving the two rods in place.
7. Unscrew and remove the two tie rods.
8. Disassemble the remaining jet stages.

**NOTE**



*Do not remove the three screws holding the fractionating tube to the top stage.*

## High Throughput Diffusion Pumps

---

To reassemble the jet:

1. If the center jet rod was removed or loosened during disassembly, thread the rod back into the boilerplate. The top of the rod should be roughly 1/16" to 1/8" below the top surface of the inlet flange (inlet plane of the pump). Once properly located, use the nut near the boilerplate to lock the rod in place.
2. Reassemble the lower stages by stacking them (outside the pump body).
3. Lower the second stage and fractionating tube into the lower jet assembly, aligning the two slots on the tube with the frame of the jet base. Ensure that the slots are engaged by attempting to rotate it.
4. Install the second stage jet shield.
5. Install the tie rods through the two holes in the cross member and thread them into the frame on the jet base.
6. Thread the two nuts on the tie rods. The height of the tie rods should be adjusted as needed by threading them into the frame of the jet base such that the rods extend above the nuts by roughly 1/8".

### CAUTION



*Do not over tighten the nuts on the tie rods. Doing so will distort the cross member. The rods are meant to hold the assembly together during installation in the pump.*

7. Using the cross member and the appropriate lifting equipment, lower the entire jet assembly into the pump body, over the center jet rod.

### CAUTION



*If the pump has been equipped with a thermowell near the bottom of the pump body, there is a corresponding slot in the jet base for clearance around the thermowell. Ensure that the slot engages the thermowell to avoid damage to the thermowell and jet.*

8. Reverse steps 1 through 3 above to reassemble the upper jet components.

### NOTE



*The hex nut is installed such that the small diameter acts to center the cold cap or halo baffle. Ensure that the hex nut is not installed upside down.*



# High Throughput Diffusion Pumps

## NHS-35 Jet Assembly

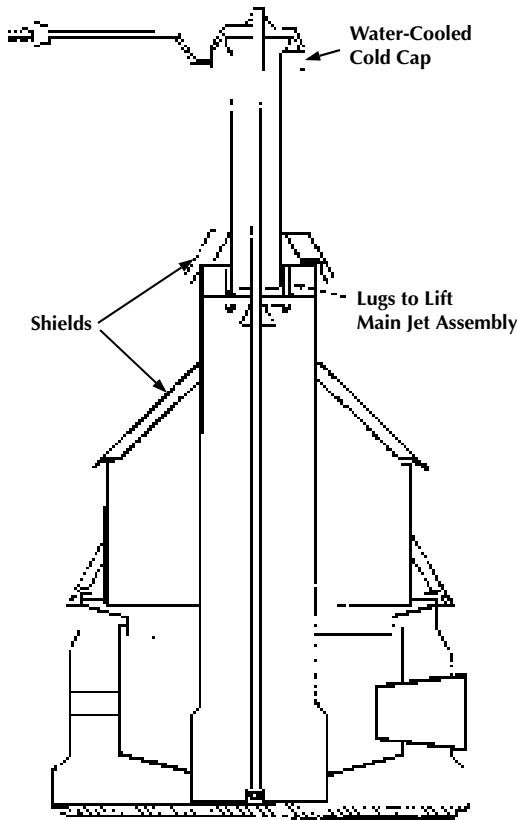

Figure 28 NHS-35 Jet Assembly

### To disassemble the jet:

1. Unscrew and remove the hex nut holding the cold cap in place. Note its orientation prior to removal
2. Remove the cold cap (or halo baffle) as described in "Cold Cap" on page 43.
3. Unscrew the top jet cap and remove.
4. Remove the spacer and top jet orifice plug.
5. Lift the second stage and jet shield over the center threaded jet rod.
6. Using the two eyebolts now accessible and appropriate lifting equipment, lift the entire lower jet assembly out of the pump body, leaving the jet rod in place.
7. Remove the third stage jet shield.
8. Remove the securing nuts and lift the third stage and fractionating tube off the fourth stage.
9. Remove the fourth state jet shield.
10. Remove the securing nuts and separate the fourth stage from the jet base.
11. Clean and service as needed.

### To reassemble the jet:

1. If the center jet rod was removed or loosened during disassembly, thread the rod back into the boilerplate. The top of the rod should be roughly 1/16" to 1/8" below the top surface of the inlet flange (inlet plane of the pump). Once properly located, use the nut near the boilerplate to lock the rod in place.
2. Reverse steps 7 through 10 above to reassemble the lower jet assembly.
3. Using the two eyebolts and the appropriate lifting equipment, lower the lower jet assembly into the pump body over the jet rod. The ejector should be aligned directly across from the foreline. A locating slot on the jet base engages a block in the pump body to ensure the ejector is properly aligned with the foreline.

### CAUTION



*The jet will not seat properly and the pump will not function unless the slot is engaged on the locator block. Check the engagement by attempting to rotate the jet once in place.*

4. Reverse steps 1 through 5 above to reassemble the upper jet components.

### NOTE



*The top jet orifice plug must be seated in the tube with the machined relief down into the tube. Ensure that the plug is not installed upside down.*

### NOTE



*The hex nut is installed such that the small diameter acts to center the cold cap or halo baffle. Ensure that the hex nut is not installed upside down.*

## Heater Replacement Procedure

Figure 29 shows the components of the heater element assembly. The heater replacement procedure is the same for all large diffusion pumps\*.

### NOTE



*During heater replacement, the crush plate\* must be replaced if the heaters are removed for inspection or maintenance.*

*\* The NHS-35 does not use a crush plate. Additional studs are used to assure adequate contact between the heater and the boiler plate.*

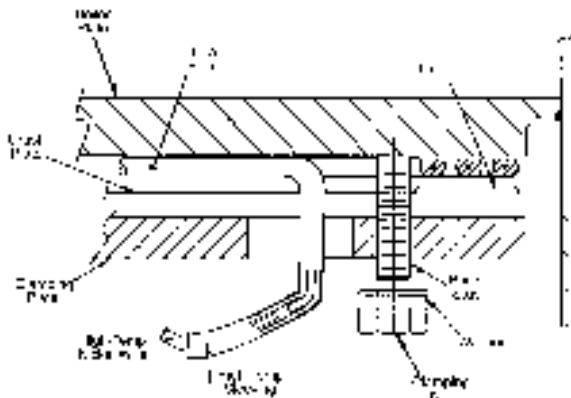

**Figure 29 Heater Element Assembly**

### WARNING



*High voltage (up to 480 V) can kill. Always break the primary circuit to the power supply before starting to work on the heater or its wiring.*

### CAUTION



*Poor clamping resulting in inadequate thermal contact may result in reduced heater life and poor pump performance.*

*Tighten nuts finger-tight on clamping plate, then gradually and evenly tighten them to 250 inches-pounds of torque.*

*To replace a heater:*

1. Use an ohmmeter at the electrical box to determine which heater element has failed.
2. Disconnect its leads from the terminal strip.
3. Pull the leads out of the terminal box and then out of the elbow cover plate.
4. Remove the heater cover from the bottom of the diffusion pump. Move the insulation to expose the faulty heaters.

5. Spray heater clamp nuts with penetrating oil.
6. Remove the nuts holding down the clamping plate.
7. Lower the entire heating unit (heater element, clamping plate and crush plate (except for the NHS-35 which does not have a crush plate) until it is off the mounting studs.

*Installing the new heater:*

1. Apply an anti-seize compound such as Loctite C5-A to the top 3/4" of the studs.

### CAUTION



*You must apply anti-seize compounds to the studs during heater replacement. Failure to do so will cause the nut to seize to the stud and increase the possibility of stud breakage during the next heater replacement.*

2. Assemble the new unit consisting of the heater element, clamping plate, and crush plate (except for the NHS-35).
3. Support the heating unit by the clamping plate, line up the holes with the boiler studs, and push the unit up against the boiler plate. Use two nuts finger-tight to hold it in place.
4. Screw on the remaining nut(s) finger-tight, then tighten all nuts evenly to 250 inches-pounds of torque.
5. Check the heater alignment with the crush plate. The heater must be located inside the crush plate tabs on all three sides.
6. Label the heater leads according to the schematic diagram.
7. Run the wires around the periphery of the pump, under the wire retaining clips, into the conduit, and up into the junction box.
8. Connect the leads to the terminal strip then replace the elbow cover plate.
9. Replace the heater insulation (not shown in Figure 29) between the high temperature nickel wires and the clamping plate.
10. Replace the heater cover.

### CAUTION



*Heater wiring and terminal lugs must not use copper or copper-plated wire which could oxidize rapidly and fail due to the high temperatures near the heaters. Use #10 strand nickel wire with high temperature insulation.*

# Troubleshooting

## Leakage

If leakage is the suspected cause of poor system performance, first check the following items:

- ❑ Inlet and foreline connections
- ❑ Drain and fill plugs
- ❑ Other compression fittings, such as high-vacuum gauges in the system
- ❑ Threaded connections, such as a foreline gauge

Before proceeding with a program of step-by-step troubleshooting, check the performance and accuracy of the vacuum gauges used on the system.

## Outgassing

High-vacuum systems, even without external leakage, can have high gas loads due to outgassing from internal surfaces or processes. The pressure in the system is a result of gas load divided by pumping speed ( $p = Q/S$ ). If the gas load  $Q$  exceeds the maximum throughput capability of the diffusion pump, the diffusion pump will not function and the pumping action will essentially be due to the mechanical backing pump.

To estimate the gas load, isolate the system from all pumps after evacuation and measure the rate of pressure increase.

The gas load can be estimated from the following relationship:

$$Q = \frac{V \times \Delta P}{\Delta t}$$

where  $V$  is the isolated volume,  $\Delta P$  is the pressure rise, and  $\Delta t$  is the time period of measurement.

## High Throughput Diffusion Pumps

### Poor Pump or System Performance

Table 25 lists the faults, the probable causes and corrective actions to take if you have a problem with a large diffusion pump.

**Table 25 Troubleshooting Guide**

Fault	Probable Cause	Corrective Action
Poor system pressure	Leaks in system, virtual or real	Locate and repair
	High process gas load	Measure gas load, eliminate cause
	System dirty	Clean system to reduce outgassing
Poor ultimate pressure	Contaminated pump fluid	Examine and clean pump; replace fluid
	Low heat input	Check voltage. Check for continuity, burned-out element, poor thermal contact
	Inadequate cooling water flow	Check water pressure. Check tubing for obstructions and backpressure
	Cooling water is too cold	Check temperature
	Cooling water flow is too high	Adjust water flow
	High forepressure	Check for leak in foreline, poor mechanical pump performance, breakdown of mechanical pump fluid
	Water in Quick Cool coil	Check and remove cause
Slow pumpdown	Low heat input	Check heaters
	Low fluid level	Add fluid
	Malfunctioning pump assembly	Check and repair or replace
	Improperly located jets	
	Damaged jet system	
Inlet pressure surges	Incorrect heater input	Check and correct
	Fluid outgassing	Condition fluid by operating the pump for a few hours
	Leak in system ahead of pump inlet	Check and correct
High chamber contamination of the pump fluid	Forepressure too high	Check for leak in foreline, poor mechanical pump performance, breakdown of pump fluid, and incorrect valve operation
	Prolonged operation in overload range	Adhere to operating procedures
	Cutting over from the backing pump too early in the pump down cycle	Cut over at a lower chamber pressure
	Improper system operation and air release procedures	Adhere to operating procedures
Pump will not start	Safety circuits or protective devices prevent contactor from staying closed	Check utilities, flow devices switches, interlocks. Check thermostat operation

# Replacement Parts

**Table 26 HS-16 Replacement Parts**

<b>Part Number</b>	<b>Description</b>
79299301	Cold cap assembly, includes No.10-32 SST Rd Hd screw and No. 10-32 SST hex nut)
L8839301	Cold cap gasket set
L8840301	Cold cap nut and follower set
83612401	Jet assembly
80798301	Foreline baffle assembly
77261001	Fill and drain plug
L8841301	Thermoswitch kit (upper and lower switch, 4' Ni wire 14 AWG, 6 Ni Lugs)
647316027	Heater element with leads (3200 W, 200 V)
647316037	Heater element with leads (2700 W, 400 V)
647316038	Heater element with leads (3200 W, 400 V)
647316039	Heater element with leads (2700 W, 430 V)
647316041	Heater element with leads (2700 W, 440 V)
647316042	Heater element with leads (3200 W, 440 V)
647316020	Heater element with leads (2700 W, 240 V Delta, 415 V WYE)
647316030	Heater element with leads (2700 W, 480 V)
647316023	Heater element with leads (3200 W, 240 V Delta, 415 V WYE)
647316033	Heater element with leads (3200 W, 480 V)
647316051	Heater element with leads (3200 W, 380 V)
647316380	Heater element with leads (2700 W, 380 V)
647316460	Heater element with leads (2700 W, 460 V)
647316021	Heater element with leads (2700 W, 575 V)
K4919001	Heater crush plate, required with heater replacement
K4917001	Heater clamping plate
79309001	Heater insulating blanket
79308001	Heater cover plate
K0377164	O-ring kit; includes: <ul style="list-style-type: none"> <li><input type="checkbox"/> 1 Butyl ASA inlet O-ring (48214001)</li> <li><input type="checkbox"/> 1 Buna-N ASA foreline O-ring (660890348)</li> <li><input type="checkbox"/> 8 Viton fill and drain O-rings (660892213)</li> <li><input type="checkbox"/> 1 Sight glass O-ring (660892232)</li> <li><input type="checkbox"/> 1 Graphite sight glass gasket (K8478001)</li> </ul>
Commercial Item	Cold cap fitting, Imperial flex fitting #66-FL, 1/2" OD tube x 3/8" FPT
K8475001	Sight glass
L6367301	Jet coupling assembly
X3900-68000	HS-16/20 heater wire, 120" 10 AWG
X3900-68006	HS-16/20 thermo switch wire, 14 AWG, 80" length
648056329	Ni lug, 14 AWG

## High Throughput Diffusion Pumps

**Table 27 HS-20 Replacement Parts**

Part Number	Description
84358301	Cold cap assembly, includes No.10-32 SST Rd Hd screw and No. 10-32 hex nut SST
L8839301	Cold cap gasket kit
F2622001	Cold cap follower, brass
75786001	Cold cap nut
622445026	Cold cap female coupling, 1/2" OD tube x 3/8" FPT, Imperial Flexfitting No. 66-FL
L6367301	Jet coupling assembly
84350301	Jet assembly
84889301	Foreline baffle assembly
F6097301	Sight glass service kit, includes glass tube, O-rings, and fittings Valves not included for pumps built prior to October 1994
77261001	Threaded plug, fill and drain
K9050001	Upper thermal switch, Temperature setting: 185 °F
K9050002	Lower thermal switch, Temperature setting: 390 °F
X3900-68006	HS-16/20 thermo switch wire, 14 AWG, 80" length
648056329	Ni lug, 14 AWG
X3900-68000	HS-16/20 heater wire, 120" 10 AWG
647320025	Heater element with leads (2,000 W, 200 V)
647320020	Heater element with leads (2,000 W, 240 V Delta, 415 V WYE)
647320035	Heater element with leads (2,000 W, 400 V)
647320040	Heater element with leads (2,000 W, 430 V)
647320045	Heater element with leads (2,000 W, 440 V)
647320030	Heater element with leads (2,000 W, 480 V)
647320208	Heater element with leads (2,000 W, 208 V)
647320022	Heater element with leads (2,000 W, 220 V)
647320050	Heater element with leads (2,000 W, 265 V)
647320380	Heater element with leads (2,000 W, 380 V)
647320044	Heater element with leads (2,000 W, 420 V)
647320046	Heater element with leads (2,000 W, 460 V)
647320075	Heater element with leads (2,000 W, 575 V)
K7108001	Crush plate, replace with each heater
K7107001	Clamping plate
L6514001	Insulation for heaters, Cerablanket 0.50" thick
84497001	Heater cover plate
L9223001	Sight glass (for pumps built after October 1994)

## High Throughput Diffusion Pumps

**Table 27 HS-20 Replacement Parts (Continued)**

Part Number	Description
K0377165	O-ring kit; includes: <ul style="list-style-type: none"> <li><input type="checkbox"/> 1 butyl O-ring for ASA inlet flange (84349002)</li> <li><input type="checkbox"/> 1 butyl foreline flange O-ring (660893432)</li> <li><input type="checkbox"/> 8 Viton fill and drain O-rings (660892213)</li> <li><input type="checkbox"/> 1 Sight glass O-ring (660892240)</li> <li><input type="checkbox"/> 1 Graphite sight glass gasket (L9228001)</li> </ul>

**Table 28 HS-32 Replacement Parts**

Part Number	Description
77252801	Cold cap assembly, includes No.10-32 SST Rd Hd screw and No. 10-32 hex nut SST
L8839301	Cold cap gasket kit
F2622001	Cold cap follower (brass)
75786001	Cold cap nut
622445026	Cold cap female coupling, 1/2" OD tube x 3/8" FPT, Imperial Flexfitting No. 66-FL
76511301	Jet assembly
F6097301	Sight glass service kit (includes glass tube, O-rings, and fittings; valves not included)
77261001	Threaded plug, fill and drain
K9050003	Upper thermal switch, Temperature setting: 220 °F
K9050004	Lower thermal switch, Temperature setting: 550 °F
X3900-68007	HS-32/35 thermo switch wire, 14 AWG, 92" length
648056329	Ni lug, 14 AWG
X3900-68003	HS-32/35 heater wire, 196" 10 AWG
F6253001	Thermal switch block, brass
647332010	Heater element with leads, No. 10 AWG (4000 W, 240 V Delta, 415 V Wye, 480 V Delta)
647332015	Heater element with leads (4000 W, 220 V)
647332040	Heater element with leads (4000 W, 400 V)
647332044	Heater element with leads (4000 W, 440 V)
K7246001	Heater crush plate, replace with each new heater
K7247001	Clamping plate
75792001	Insulation for heaters – Cerablanket 0.50" thick
75791001	Heater cover
670099910	Insulation for conduit
L9223001	Sight glass (for pumps built after October 1995)

## High Throughput Diffusion Pumps

**Table 28 HS-32 Replacement Parts (Continued)**

Part Number	Description
K0377167	O-ring kit; includes: <ul style="list-style-type: none"> <li><input type="checkbox"/> 1 butyl O-ring for ASA inlet flange (45390001)</li> <li><input type="checkbox"/> 1 butyl O-ring foreline flange (2-443)</li> <li><input type="checkbox"/> 8 Viton fill and drain O-rings (2-213)</li> <li><input type="checkbox"/> 1 Sight glass O-ring (2-240)</li> <li><input type="checkbox"/> 1 Graphite sight glass O-ring (L9228001)</li> <li><input type="checkbox"/> 4 Viton O-rings (2-221)</li> </ul>

**Table 29 NHS-35 Replacement Parts**

Part Number	Description
F1971302	Jet Assembly
81437301	Cold cap assembly (includes No.10-32 SST Rd Hd screw and No. 10-32 hex nut) SST
L8839301	Cold cap gasket kit
F2622001	Cold cap follower (brass)
75786001	Cold cap nut
622445026	Cold cap female coupling, 1/2" OD tube x 3/8" FPT, Imperial Flexfitting No. 66-FL
F1744301	Foreline baffle assembly
77261001	Threaded plug, fill and drain
K9050005	Upper thermal switch, Temperature setting: 200 °F
K9050006	Lower thermal switch, Temperature setting: 600 °F
647335010	Heater element with leads (4000 W, 240 V Delta, 415 V WYE, 480 V Delta)
647335012	Heater element with leads (4000 W, 220 V)
647335380	Heater element with leads (4000 W, 380 V)
647335014	Heater element with leads (4000 W, 460 V)
L6383010	Heater element with leads (4000 W, 400 V)
L6383011	Heater element with leads (4000 W, 440 V)
F1749001	Clamping plate (no crushplate in NHS-35)
L9699001	Insulation for heaters – Cerablanket 0.50" thick
L9223001	Sight glass (for pumps built after October 1995)
K0377169	O-ring kit; includes: 1 Butyl O-ring for ASA inlet flange (78536001) <ul style="list-style-type: none"> <li><input type="checkbox"/> 1 Butyl O-ring foreline flange (2-267)</li> <li><input type="checkbox"/> 8 Viton O-rings fill and drain (2-213)</li> <li><input type="checkbox"/> 1 Sight glass O-ring (2-240)</li> <li><input type="checkbox"/> 1 Graphite sight glass gasket (L9228001)</li> <li><input type="checkbox"/> 4 Viton O-rings (2-221)</li> </ul>
78536002	O-ring for ISO inlet flange
X3900-68007	HS-32/35 thermo switch wire, 14 AWG, 92" length
648056329	Ni lug, 14 AWG



## High Throughput Diffusion Pumps

---

**Table 29 NHS-35 Replacement Parts (Continued)**

Part Number	Description
X3900-68003	HS-32/35 heater wire, 196" 10 AWG

*This page intentionally left blank.*

## Vacuum Products Division Instructions for returning products

Dear Customer:

Please follow these instructions whenever one of our products needs to be returned.

- 1) Complete the attached Request for Return form and send it to Agilent Technologies (see below), taking particular care to identify all products that have pumped or been exposed to any toxic or hazardous materials.
- 2) After evaluating the information, Agilent Technologies will provide you with a Return Authorization (RA) number via email or fax, as requested.  
**Note:** Depending on the type of return, a Purchase Order may be required at the time the Request for Return is submitted. We will quote any necessary services (evaluation, repair, special cleaning, eg).
- 3) **Important steps for the shipment of returning product:**
  - Remove all accessories from the core product (e.g. inlet screens, vent valves).
  - Prior to shipment, drain any oils or other liquids, purge or flush all gasses, and wipe off any excess residue.
  - If ordering an Advance Exchange product, **please use the packaging from the Advance Exchange to return the defective product.**
  - Seal the product in a plastic bag, and package product carefully to avoid damage in transit. You are responsible for loss or damage in transit.
  - Agilent Technologies is not responsible for returning customer provided packaging or containers.
  - **Clearly label package with RA number.** Using the shipping label provided will ensure the proper address and RA number are on the package. Packages shipped to Agilent without a RA clearly written on the outside cannot be accepted and will be returned.
- 4) Return only products for which the RA was issued.
- 5) **Product being returned under a RA must be received within 15 business days.**
- 6) **Ship to the location specified on the printable label, which will be sent, along with the RA number, as soon as we have received all of the required information.** Customer is responsible for freight charges on returning product.
- 7) Return shipments must comply with all applicable **Shipping Regulations** (IATA, DOT, etc.) and carrier requirements.

RETURN THE COMPLETED **REQUEST FOR RETURN** FORM TO YOUR NEAREST LOCATION:

**EUROPE:**

Fax: 00 39 011 9979 330  
Fax Free: 00 800 345 345 00  
Toll Free: 00 800 234 234 00  
[vpt-customer@agilent.com](mailto:vpt-customer@agilent.com)

**NORTH AMERICA:**

Fax: 1 781 860 9252  
Toll Free: 800 882 7426, Option 3  
[vpl-ra@agilent.com](mailto:vpl-ra@agilent.com)

**PACIFIC RIM:**

please visit our website for individual office information  
<http://www.agilent.com>

**Vacuum Products Division  
Request for Return Form  
(Health and Safety Certification)**

Please read important policy information on Page 3 that applies to all returns.

**1) CUSTOMER INFORMATION**

<b>Company Name:</b>		<b>Contact Name:</b>	
<b>Tel:</b>	<b>Email:</b>	<b>Fax:</b>	
<b>Customer Ship To:</b>		<b>Customer Bill To:</b>	
Europe only: <b>VAT reg. Number:</b>		USA/Canada only: <input type="checkbox"/> <b>Taxable</b> <input type="checkbox"/> <b>Non-taxable</b>	

**2) PRODUCT IDENTIFICATION**

Product Description	Agilent P/N	Agilent S/N	Original Purchasing Reference

**3) TYPE OF RETURN** (Choose one from each row and supply Purchase Order if requesting a billable service)

- 3A.  Non-Billable  Billable **➔** New PO # (hard copy must be submitted with this form):
- 3B.  Exchange  Repair  Upgrade  Consignment/Demo  Calibration  Evaluation  Return for Credit

**4) HEALTH and SAFETY CERTIFICATION**

**AGILENT TECHNOLOGIES CANNOT ACCEPT ANY PRODUCTS CONTAMINATED WITH BIOLOGICAL OR EXPLOSIVE HAZARDS, RADIOACTIVE MATERIAL, OR MERCURY AT ITS FACILITY.**  
**Call Agilent Technologies to discuss alternatives if this requirement presents a problem.**

**The equipment listed above (check one):**

**HAS NOT** pumped or been exposed to any toxic or hazardous materials. OR

**HAS** pumped or been exposed to the following toxic or hazardous materials. If this box is checked, the following information must also be filled out. Check boxes for all materials to which product(s) pumped or was exposed:

Toxic  Corrosive  Reactive  Flammable  Explosive  Biological  Radioactive

**List all toxic/hazardous materials. Include product name, chemical name, and chemical symbol or formula:**

---

**NOTE:** If a product is received at Agilent which is contaminated with a toxic or hazardous material that was not disclosed, **the customer will be held responsible** for all costs incurred to ensure the safe handling of the product, and **is liable** for any harm or injury to Agilent employees as well as to any third party occurring as a result of exposure to toxic or hazardous materials present in the product.

**Print Name:** \_\_\_\_\_ **Authorized Signature:** ..... **Date:** \_\_\_\_\_

**5) FAILURE INFORMATION:**

Failure Mode (REQUIRED FIELD. See next page for suggestions of failure terms):
Detailed Description of Malfunction: (Please provide the error message)
Application (system and model):

<b>I understand and agree to the terms of Section 6, Page 3/3.</b>		
<b>Print Name:</b>	<b>Authorized Signature:</b> .....	<b>Date:</b>

**Vacuum Products Division  
Request for Return Form  
(Health and Safety Certification)**

Please use these Failure Mode to describe the concern about the product on Page 2.

**TURBO PUMPS and TURBO CONTROLLERS**

APPARENT DEFECT/MALFUNCTION	POSITION	PARAMETERS
- Does not start - Does not spin freely - Does not reach full speed - Mechanical Contact - Cooling defective - Noise - Vibrations -Leak -Overtemperature -Clogging	- Vertical -Horizontal -Upside-down -Other: .....	Power:                      Rotational Speed: Current:                    Inlet Pressure: Temp 1:                      Foreline Pressure: Temp 2:                      Purge flow: OPERATING TIME:

**ION PUMPS/CONTROLLERS**

- Bad feedthrough	- Poor vacuum
- Vacuum leak	- High voltage problem
- Error code on display	- Other

**VALVES/COMPONENTS**

- Main seal leak	- Bellows leak
- Solenoid failure	- Damaged flange
- Damaged sealing area	-Other

**LEAK DETECTORS**

- Cannot calibrate	-No zero/high background
- Vacuum system unstable	- Cannot reach test mode
- Failed to start	- Other

**INSTRUMENTS**

- Gauge tube not working	- Display problem
- Communication failure	- Degas not working
- Error code on display	- Other

**SCROLL AND ROTARY VANE PUMPS**

- Pump doesn't start	- Noisy pump (describe)
- Doesn't reach vacuum	- Over temperature
- Pump seized	- Other

**DIFFUSION PUMPS**

- Heater failure	- Electrical problem
- Doesn't reach vacuum	- Cooling coil damage
- Vacuum leak	- Other

Section 6) **ADDITIONAL TERMS**

**Please read the terms and conditions below as they apply to all returns and are in addition to the Agilent Technologies Vacuum Product Division – Products and Services Terms of Sale.**

- Customer is responsible for the freight charges for the returning product. Return shipments must comply with all applicable **Shipping Regulations** (IATA, DOT, etc.) and carrier requirements.
- Customers receiving an Advance Exchange product agree to return the defective, rebuildable part to Agilent Technologies **within 15 business days**. Failure to do so, or returning a non-rebuildable part (crashed), will result in an invoice for the non-returned/non-rebuildable part.
- Returns for credit toward the purchase of new or refurbished Products are subject to prior Agilent approval and may incur a restocking fee. Please reference the original purchase order number.
- Units returned for evaluation will be evaluated, and a quote for repair will be issued. If you choose to have the unit repaired, the cost of the evaluation will be deducted from the final repair pricing. A Purchase Order for the final repair price should be issued within 3 weeks of quotation date. Units without a Purchase Order for repair will be returned to the customer, and the evaluation fee will be invoiced.
- A Special Cleaning fee will apply to all exposed products per Section 4 of this document.
- If requesting a calibration service, units must be functionally capable of being calibrated.

*This page intentionally left blank.*

