



Linkam Scientific Instruments

THMSG600

Temperature Controlled Geology Stage

USER GUIDE

Contents

Before Setting Up Your Equipment.....	3
Important Notice.....	4
Warranty.....	4
Technical Support.....	4
Equipment Maintenance.....	4
Handling Liquid Nitrogen.....	4
Feedback.....	4
Safety Precautions.....	5
Symbol Reference.....	5
Introduction.....	6
THMSG600 Stage Specification.....	6
THMSG600 System.....	6
Stage Anatomy.....	7
Stage Assembly.....	7
Lid Assembly.....	7
Mounting Stage to Microscope with Dovetail Substage.....	8
Setting up the Condenser.....	8
Vacuum Tweezers.....	9
Connecting the Instruments.....	10
T95 System Controller Cable Connections.....	10
LNP95 Cooling Pump Connection.....	10
Remove Transit Screws.....	10
Back Panel Cable Connection.....	10
ECP Water Circulator Pump.....	11
Sample preparation.....	12
G7T Sample Holder with Silver Lid.....	12
THMS/CC Crucible Carrier and Quartz Crucible.....	15
Cooling Connections.....	17
Purging Procedure.....	18
Use LinkPad to set the LNP95 to Manual Mode.....	18
Filling the Liquid Nitrogen Dewar.....	18
Purging the Stage Method 1.....	19
Purging the Stage Method 2.....	20
Appendix.....	21
Window Assembly.....	21
Lid Window Assembly.....	21
Bottom Window Assembly.....	21
Spares and Accessories.....	22
Troubleshooting.....	24
Contact Details.....	28

Before Setting Up Your Equipment

Please register your products by going to www.linkam.co.uk and click on the product/software registration button.

You will need to register your equipment with us to:

- Activate your warranty and technical support
- Access the online setup videos
- Permanently unlock the Linksys32 software (if purchased)

If you have purchased Linksys32 software, please install the software first. This process will guide to register all of your products.

See Linksys32 manual for further installation instructions.

A CD with a setup videos is supplied with your system.

Important Notice

Please check that your Linkam equipment has not been damaged during transit. If there is any evidence of external damage **DO NOT SWITCH ON ANY ELECTRICAL ITEMS**.

Contact LINKAM SCIENTIFIC or their appointed distributor immediately. Your warranty may be impaired if Linkam is not informed of any transport damage within 7 working days of delivery.

NO attempt should be made to repair or modify the equipment in any way, as there are **no user replaceable parts**.

No attempt should be made to open the case except by qualified personnel as hazardous voltages are present.

In order to use this equipment successfully, please take time to read this manual all the way through before using it.

Warranty

This equipment has a warranty against defects in material and workmanship for a period of 12 months. Linkam will either repair or replace products that prove to be defective. For warranty service or repair, this product must be returned to Linkam or a designated service facility.

The warranty shall not apply to defects resulting from interfacing, unauthorized modification or misuse, operation outside of the environmental specifications for the product, or improper site preparation or maintenance.

Technical Support

Any technical questions or queries should be addressed to the Technical Support Department at the address shown on the back of this manual.

Equipment Maintenance

Use a small quantity of isopropyl alcohol with a soft cloth and gently wipe the surface. To clean the hot-stage, use isopropyl alcohol (IPA) and cotton swabs. Take great care not to touch the platinum temperature sensor protruding from the side of the heating element. The sensor is very fragile.

Handling Liquid Nitrogen

To cool samples below room temperature a LNP95 liquid nitrogen pump is required. Please refer to your health and safety manual for instructions on how to handle liquid nitrogen safely. The Dewar supplied with the LNP95 has a safety release valve built into the siphon assembly. Always use in a well ventilated room.

Feedback

Your feedback will be greatly appreciated, please go to www.linkam.co.uk to fill in the Feedback form.

Safety Precautions

- 1) Read this guide before using the equipment. Save these instructions for later use.
- 2) Follow all warnings and instructions which may be placed on the programmer or stage.
- 3) If for any reason the mains fuse needs to be replaced then it must be replaced by one of the same type and rating as shown in the equipment ratings.
- 4) To prevent electric shock, do not remove the cover of the controller or associated electronics.
- 5) Never use the equipment if a power cable has been damaged. Do not allow any heavy objects to rest on the power cables. Never lay the power cables on the floor.
- 6) Do not obstruct any ventilation holes. Do not attempt to insert anything into these openings. Provide adequate ventilation of at least 75mm all around the equipment.
- 7) Do not expose the equipment to water. If for any reason it gets wet then unplug it from the mains and contact Linkam Scientific Technical Support.
- 8) The equipment is not intended to be used outdoors.
- 9) Each product is equipped with a 3-wire grounded (earth) mains plug or a free-end 3 wire mains lead. The plug only fits into a grounded-type outlet. The free-end mains lead should be connected to a correctly grounded 3-wire mains outlet. Do not defeat the purpose of the grounded (earth) type plug.

Free - end mains leads are colour coded as follows :

Colour	Function
Brown	Live
Blue	Neutral
Green/Yellow	Earth (Ground)

- 10) If any problems occur then unplug the equipment from the mains outlet and contact Linkam Scientific Technical Support.
- 11) Do not remove the cover from the equipment unless the mains inlet has been removed. Any servicing should be carried out by qualified service personnel.

Symbol References

Caution:

This safety symbol is on the back panel of the equipment and warns:-



The user must not make or remove any connections while the unit is powered on. To avoid electric shock do not remove the cover. Refer servicing to qualified service personnel.

Caution:



This warning symbol indicates that the surface labelled with this symbol may be hot.

Introduction

Thank you for purchasing the THMSG600 temperature controlled geology system. Please take the time to read through the manual as it will help you to make the most out of the equipment.

THMSG600 Stage Specifications

Maximum temperature:	600°C
Minimum temperature:	-196 °C with LNP95
Maximum heating rate:	150°C/min
Objective Lens WD:	4.5mm
Condenser lens WD:	12.5mm
XY-Manipulators travel:	16mm
Aperture hole:	1.3mm
Weight:	0.62Kg



THMSG600 System

The system consists of a THMSG600 stage, a T95-LinkPad System Controller and LNP95 liquid nitrogen cooling pump system.

Linksys32 System control software and digital video capture can be added as an option to control from PC. If Linksys32 is supplied with the system please install the software first and activate the licence key. See Linksys32 manual for more information

The THMSG600 stage is mounted onto the microscope by using either specific stage clamps, an adaptor plate or by simply placing on the XY table of the microscope, using double sided adhesive tape.

Stage Anatomy

Stage Assembly

1. Lemo connector for stage lead
2. Heating element carrier assembly
3. Stage body
4. Stage body water connector
5. Gas purge valve
6. Y-Sample manipulator
7. Stage door
8. Door locking thumbscrew
9. X-Sample manipulator
10. Liquid nitrogen cooling connector
11. Bypass stage body water cooling connector
12. Sample chamber
13. Earth safety contact for lid

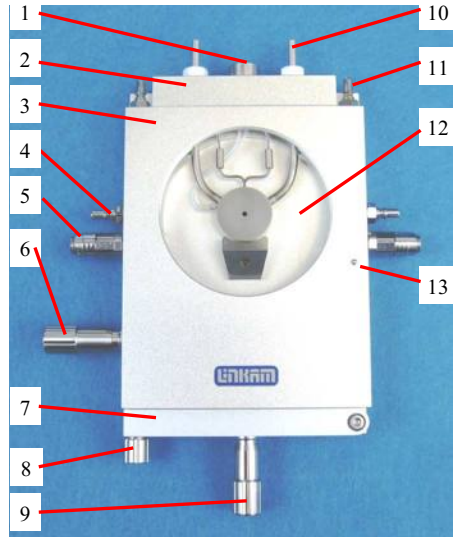

15. Heating element wire
16. Stainless steel cooling tube
17. 22mm diameter pure silver heating block
18. Platinum temperature sensor
19. Sample holder ramp
20. Aperture hole

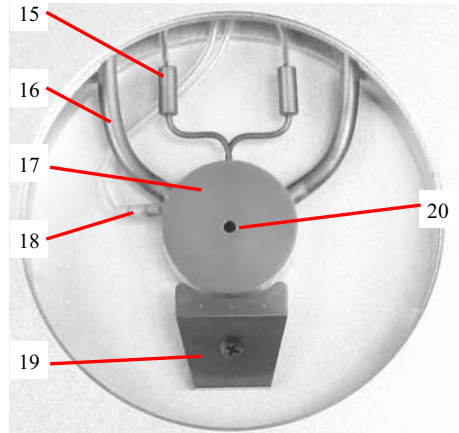

Lid Assembly

The Stage Lid is removed from the stage by unscrewing anti-clockwise.

21. Stage Lid
22. Lid Insert
23. Viewing Window (0.17x22mm glass)
24. Holes for Tube Clip Holder or window removal tool

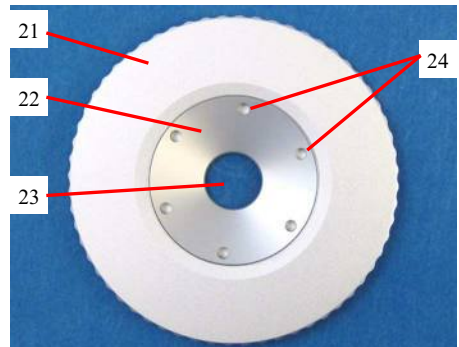

Mounting Stage to Microscope with Dovetail Substage

The following description is for mounting the stage on to microscopes which have a circular dovetail substage assembly (1).

Attach the curved stage clamps (part no. 9542) to the base of the stage using the supplied hex screws and the outer most holes in the base plate.

Adjust the two positioning screws (2) so that approximately 5mm of thread is exposed on the inside edge of the clamp. This will roughly position the stage in the centre of the dovetail.

Place the stage onto the dovetail, then focus a 10X objective lens on the aperture of the silver block. Using the two positioning screws (2) ensure that the aperture is in the centre of the field of view and lock the stage in place by tightening the Locking Thumbscrew (3).

For other types of microscope substage, refer to the diagram included with the stage adaptor.

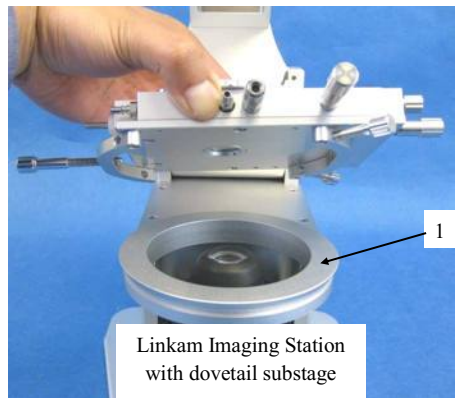
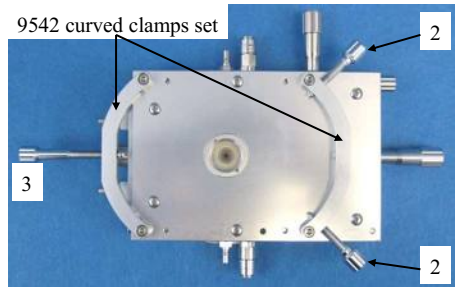

Setting up the Condenser for Koehler Illumination.

Place a small sample on a cover slip and place onto the surface of the silver block. Use a 5X or a 10X lens to focus on the sample. Now close down the microscope field diaphragm and adjust the condenser focus so that the edges of the diaphragm are in focus. Now use the condenser positioning screws to centre the condenser in your field of view. Open the diaphragm so that it just fills the field of view.

For more information about Koehler illumination see the extremely informative 'Microscopy Primer' on the Molecular Expressions website.

<http://micro.magnet.fsu.edu/primer/index.html>

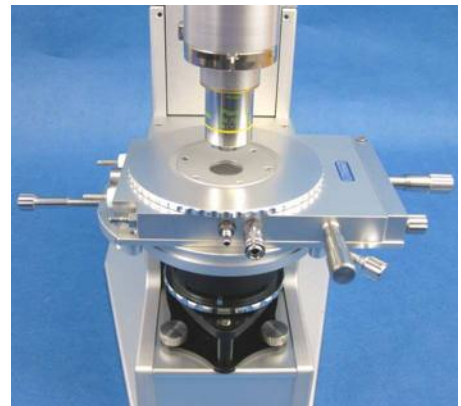

Vacuum Tweezers

The vacuum tweezers are used to manipulate the sample windows onto the silver block to prevent fingerprints on the glass and scratching the surface of the silver block when using standard fine tip metal tweezers.

The System is supplied with a Vacuum Tweezers Kit which consists of a Vacuum Pump (1) and tweezers (2).

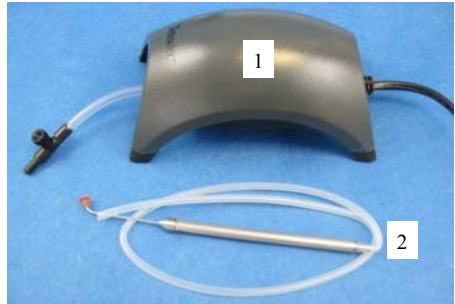

Connect the tubing at the end of the tweezers to the Regulator Valve (3) connection.

Use the dial on the valve to adjust the vacuum for the tweezers.

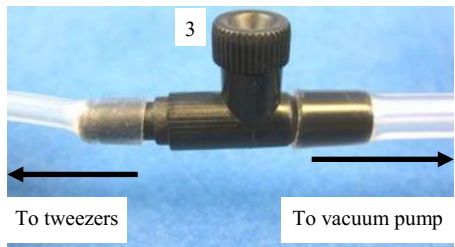

Use a finger to block the hole of the tweezers to pick up a sample cover slip with the suction cup.



Release the finger to drop the sample cover slip.



Connecting The Instruments

T95 System Controller Cable Connections

For more details on the T95 System Controller please refer to the T95 System Controller manual.

Connect the Stage Cable to the Lemo Connector on the stage and connect the other end to the Stage Connection Socket (1).

When connecting an LNP95 cooling pump you must switch this on **BEFORE** you switch on the T95 controller.

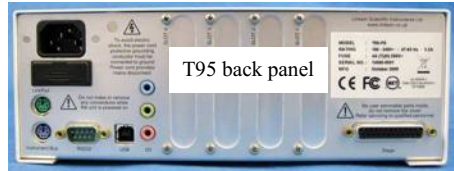

LNP95 Cooling Pump Connection

Remove Transit Screws

Before using the LNP95 Liquid Nitrogen Pump System, remove the 4 transit screws, marked by small yellow labels, from the base of the LNP95. Transit screws shown by arrows in the adjacent image. These screws hold the pumps in place for shipping.

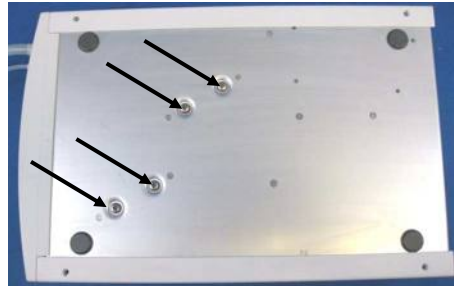

Keep the screws safe by screwing them into the holes on the back panel as shown by the arrows.



The screws must be replaced back into the transit holes on the base, when shipping back to Linkam for service or repair.

Back Panel Cable Connection

Connect the Instrument Bus Cable (2) between the LNP95 and T95 as shown.

Note: either of the purple coloured Instrument Bus Sockets on the LNP95 can be used.

LNP95 MUST BE SWITCHED ON BEFORE T95 SYSTEM CONTROLLER



Setting up ECP Water Circulator Pump

If you have purchased the ECP with the system, read the following to set up the ECP with the THMSG600 stage. Refer to the ECP manual for more details.



When heating the stage above 300°C for a prolonged period of time, the metal casing body of the stage can get quite hot. Connect the tubing from the ECP as shown in the opposite picture to cool the stage.

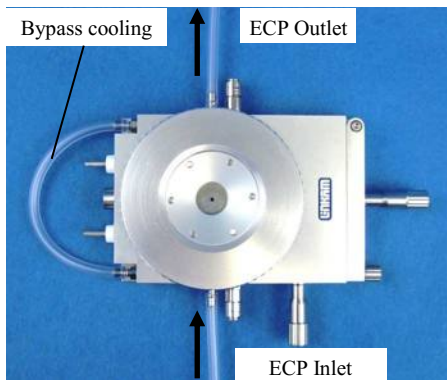

Note: the performance of the stage is not effected whether the ECP is in use or not.

Note: If you have an LNP95 Liquid Nitrogen Cooling system, the tubing from the Dewar must not be connected to the THMSG600 stage when heating above 300°C. The thin black capillary tube will melt inside the heater and damage it.

Sample Preparation

When working with fluid inclusions both the optical performance and the temperature performance becomes critical. It is very important to avoid using too many glass cover slips as each layer affects the sharpness of the image seen by the microscope.

For accurate results it is most important that the surface of the block, window and carrier are extremely clean, since air gaps between the silver block and the sample window will result in temperature errors.

The block is made of silver and since it is a soft metal it can get scratched easily especially by using sharp fine tweezers. This can cause a ridge to form which prevents the sample window from sitting flat on the block with the resulting air gap causing significant temperature errors.

For this reason we recommend that the sample and windows are always handled using the Linkam Vacuum Tweezers.

G7T Sample Holder with Silver Lid

The G7T (1) has a tapered internal edge (2) to enable the straight edge of the 7mm sapphire or quartz window to locate correctly inside the holder.

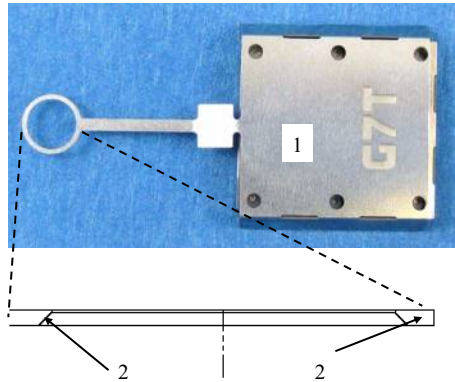

To load the sample holder open the side door of the stage and slide the G7T in. Push the sample holder as far as it will go then gently push the door shut and lock the door in place with the thumb screw.



The circular end of the sample holder will go up the Sample Holder Ramp (1) ramp and rest on surface of the silver block.

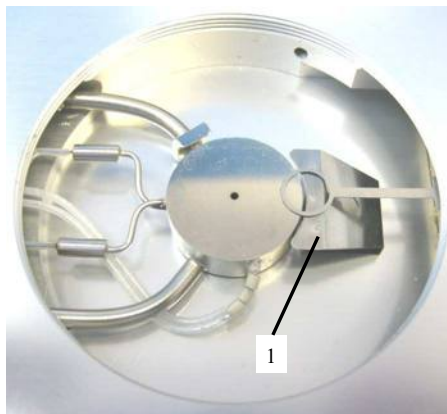

Place a 7mm W7S sapphire or a W7Q quartz window (2) using the vacuum tweezers onto the surface of the silver block next to the end of the sample holder.

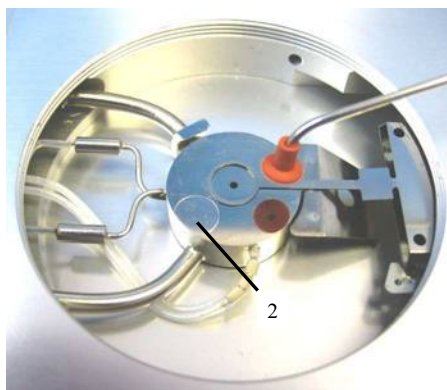

With one hand carefully lift the G7T about 1mm off the silver heating block and slide the 7mm sample window directly underneath the circular sample holder. Release G7T and it should clip the sample window into place.



Adjust the XY-manipulators by a few turns in both directions to make sure the 7mm sample window is fitted securely in place.

Now load the sample onto the top of the sample window.

Place the Silver Cover Lid (SCO) on top of the silver heating block as shown in the opposite picture. Make sure the gap in the SCO (1) is aligned with the stem (2) of the Sample holder.

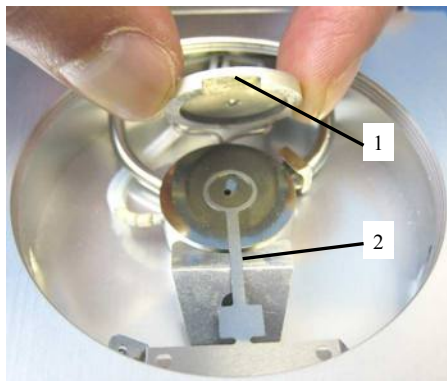

The gap in the SCO allows movement of the Sample Holder when the XY manipulators are used.

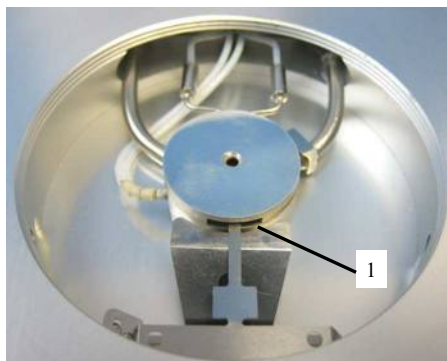

To improve temperature stability an optional 13mm glass window (W13G) (3) can be used to cover the aperture hole of the SCO.

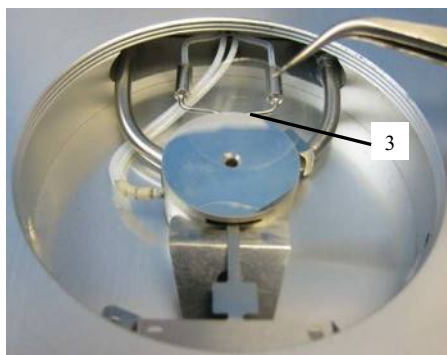

THMSG/CC Crucible Carrier and Quartz Crucible

For larger samples or liquids, use the crucible carrier (1) and quartz crucible. By using this sample holder samples can be loaded into the stage without removing the stage lid. The crucible carrier is loaded through the side door.

The crucible carrier has two spring clips to hold the crucible flat against the silver block. This is to ensure good thermal contact.

To load the quartz crucible into the carrier, lift the two spring clips about 2mm upward and slide the crucible in to the holder.

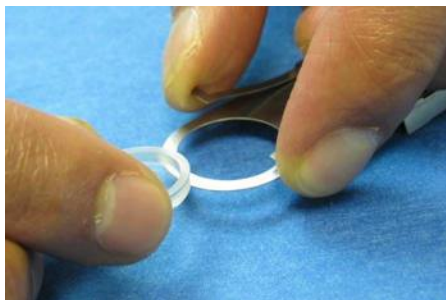
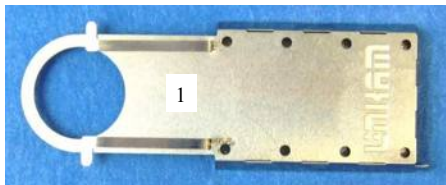

Release the two spring clips to hold the Crucible in place



Load the sample into the quartz crucible. Use as little sample as possible to ensure a small thermal load and therefore better temperature sensitivity.

Microscope objectives require a flat surface to give maximum field of view. Place a 13mm coverslip on top of your sample and gently tap the top with the back of the vacuum tweezers to disperse powder samples or ensure good thermal contact of irregularly shaped samples.

Open the side door of the stage by unscrewing the thumbscrew and carefully push the THMSG/CC and crucible into the XY slide mechanism.



The crucible will be guided to the surface of the silver block by the Sample Holder Ramp. Close the door and tighten the thumbscrew to seal the stage.

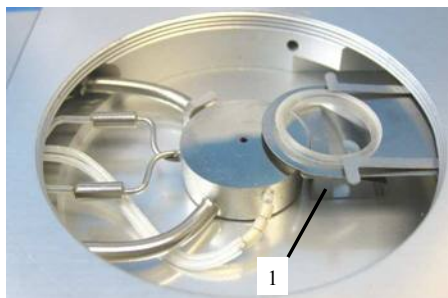

Cooling Connections

These connections need only be made if the experiments are to be carried out below room temperature.

The Dewar siphon (1) is the thick white foam tubing and is attached to the liquid nitrogen Dewar. The thin black capillary tube inside the white foam tube must be inserted into the liquid nitrogen cooling connectors on the stage.

The white tubing slides on to the outside of the connector. Twist the siphon whilst sliding it on and push until it comes to a stop. It does not need to go all the way to the base of the connector.

The thicker silicon tube from the LNP95 cooling pump ends in a white PTFE connector (2), this is pushed over the end of the other stainless steel connector as seen in the image.

The short tube branching from the side of this white connector is the Gas Purging Tube (3). There is a valve opening Insert connector (4) inserted into the end of this tube. During the purging procedure, insert this connector into the Gas Purge Valve (5) on the side of the stage to open it.

The Gas Purge Valve (5) is opened when the Gas Insert (6) is pushed firmly into the connector, a “click” is heard when the two parts are connected properly. To remove the Gas Insert, push the outer sleeve of Gas Purge Valve toward the stage and the Gas Insert (6) should drop out.

There is a second Gas Purge Valve on the opposite side of the stage to allow the gas to leave the stage. A Gas Insert must also be inserted into this Gas Purge Valve (7) when purging.

The smaller tube from the outlet on the LNP95 should be placed in position on the top of the lid using the Tube Clip Holder (8). This tube blows warm recycled nitrogen gas across the lid window to prevent condensation on the viewing window surface.

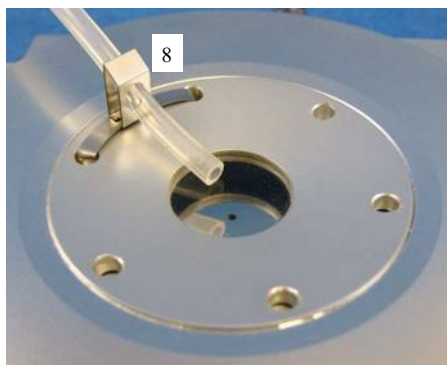
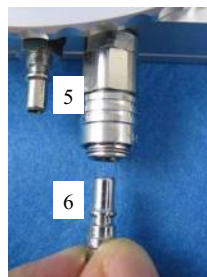
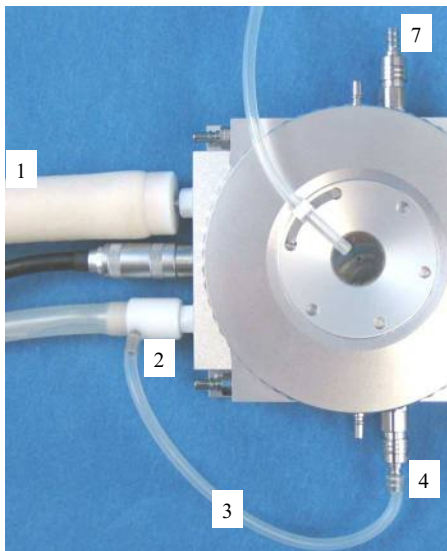

Purging Procedure

Before starting a cooling experiment, you will need to purge air from the stage chamber with dry nitrogen . This will remove the water in the air which would otherwise condense and freeze on the sample disrupting your image quality.

Before you can start purging, the LNP95 must be set to manual mode.

You can either use the LinkPad touch screen or Linksys 32 software.

Use LinkPad to set the LNP95 to Manual Mode

Touch the active area (1) under 'Lnp Speed' to change to the LNP Screen Menu. Touch 'Man' (2) to switch the LNP95 to manual mode.

The word 'auto' is changed to 'speed' to indicate the LNP95 is functioning in manual mode.

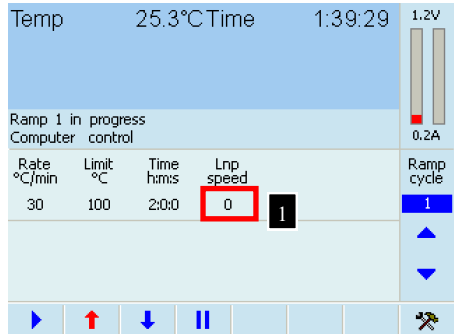

Using the Keypad type in 100 (max pump speed) and touch the 'Enter' button (4) to start the LNP95 at the programmed speed (5).

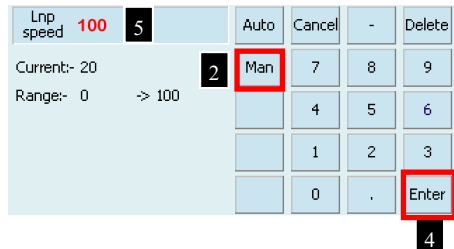

Filling the Liquid Nitrogen Dewar

Please follow your health and safety manual for directions on how to handle liquid nitrogen and ensure that you have the correct safety equipment including gloves and safety goggles.

Fill the dewar until approximately 2/3 full and replace the lid with siphon attached.

DO NOT FASTEN THE CATCHES.

Wait for the nitrogen to stop bubbling before fastening the catches.

Take care when placing lid on a table to always have the black capillary pointing upwards. It is easily damaged which will impair N2 flow.

Purging the Stage Method 1

There are two methods for purging the stage. Method 1 uses recycled nitrogen gas produced by the LNP95 from the 2L Dewar.

1. Make sure the stage lid is in place and the stage door is closed.
2. Switch on the temperature programmer and set the limit to 40°C. Press the START button and wait until the temperature limit is reached. Press HOLD to hold the temperature at 40°C.
3. Switch on the LNP95 cooling system and set it to manual mode, (see page 17) and set the speed to maximum of 100.
4. Check that the Gas Inserts are locked into place
5. Using a finger on the left hand, block the hole in the white plastic pump connector found on the perpendicular side to the purging tube. Still working with the left hand, pinch the narrow window tube to block it. This action will divert all of the nitrogen gas to the Purging Tube and through the Stage Chamber.
6. With the nitrogen gas flowing through the Sample Chamber, use a finger on the right hand to block the gas outlet for a few seconds to allow pressure build, then release the gas . Do this for a few minutes to purge the stage.
7. Look at the change of reflection in the stage window as the stage is pressurised and released to check that the stage is properly sealed. If there is no change, there may be a leak due to incorrect placing of the silicon o-rings in either the bottom or lid window or the window (top/bottom may be broken).
8. The purging procedure allows mixing of nitrogen gas with the residual air inside the Sample Chamber. By pressurising the chamber with nitrogen gas and releasing it, the air inside the Chamber is being diluted with the nitrogen gas.
9. Remove the two Gas Inserts and unblock the pump connector and window tube.
10. Change the LNP95 to **AUTOMATIC** mode so that the T95 automatically controls pump speed during your cooling experiment
11. Go to www.linkam.co.uk and register your equipment to see videos of how to purge and more.

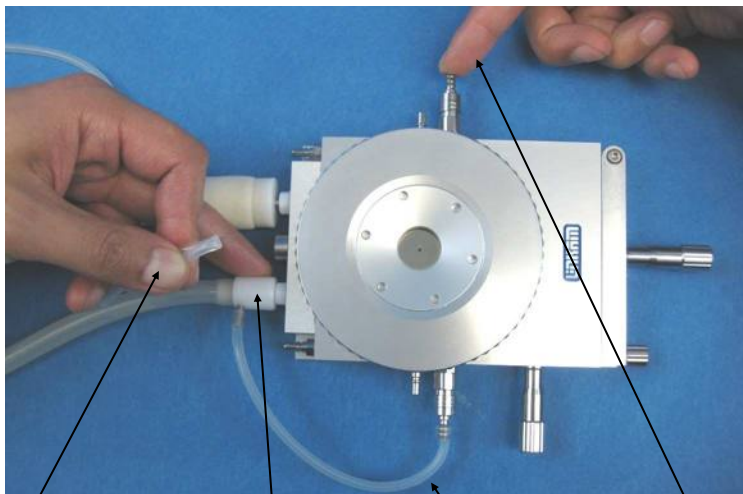

Pinch window tube
with left hand

Block hole in
Connector with finger
pump connector

Purging
tube

Block and release outlet
valve with finger

Purging the Stage Method 2

This method uses an inert gas from a gas cylinder to purge the stage at temperatures above ambient when the LNP95 is not required.

1. Make sure the Stage Lid is in place and the Stage Door is closed.
2. From a gas cylinder connect the Gas Insert with a tubing 3mm inner diameter and 6mm outer diameter to the Gas Purge Valve (1).
3. Connect a Gas Insert to the opposite side Gas Purge Valve (2).
4. Use the gas regulator to set a gas flow rate of 1.5L/min.
5. With the gas flowing through the Sample Chamber, block the gas outlet for a few seconds and releasing the gas outlet valve with a finger. Do this for a few minutes to purge the stage.

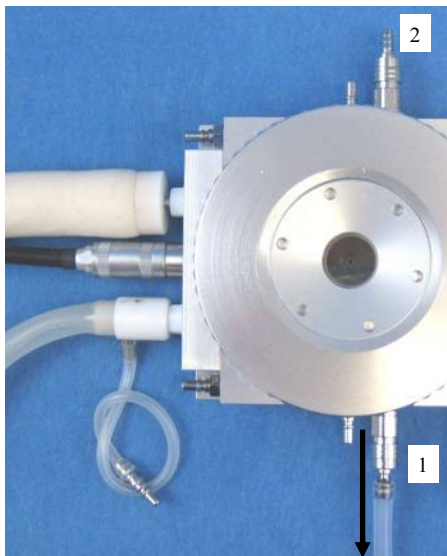

To gas cylinder

Reduce the gas flow rate to 20cc/min to continuously purge the stage or remove the two Gas Inserts to keep the chamber under closed inert atmosphere.

Note: Helium gas is not recommended for continuous purging. This gas has a very high thermal conductivity and will cool the silver heating block too much during an experiment and may cause the temperature to fluctuate.

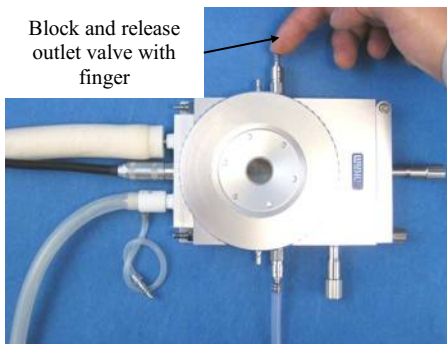

Appendix

Window Assembly

Lid Window Assembly

To replace the windows in the Stage Lid (1) use the Window Tool (2) and align the two wide spacing pins to the Tube Clip Holder holes and unscrew the Lid Insert (3).

The Stage Lid and Lid Insert should be turned upside down as shown in the diagram opposite and reassembled in the order indicated.

The Lid Insert should be screwed down until the cover slips are held firmly, then turn the assembly over and screw down the Lid Insert until it is felt to come to a stop.

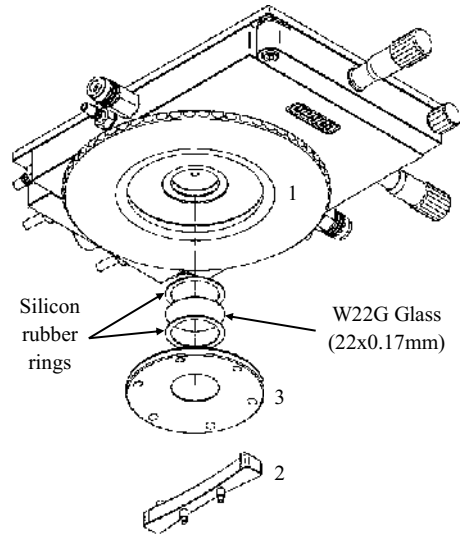

Bottom Window Assembly

Use two narrow spacing pins of Window Tool (2) to align it to the two holes of Window Locking Ring (4) and unscrew.

Reassemble the bottom window as shown in the opposite diagram

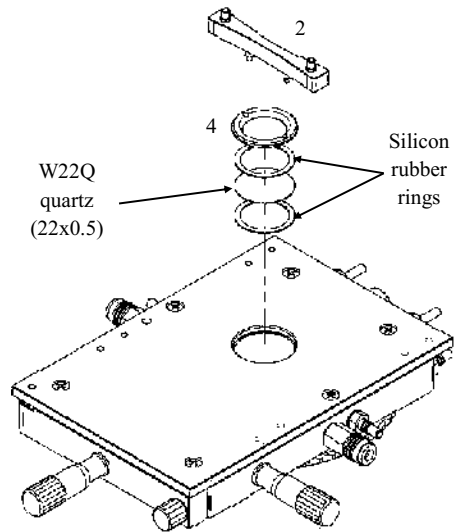

Spares

These spares are organised into convenient kits. Purchase a spares kit to avoid downtime with your stage and eliminate future shipping costs.

The THMSG600 heating element is extremely durable if used carefully. However, it is made from pure silver which is a soft metal. It can be easily scratched, which will compromise the heat flow to the sample and reduce accuracy. The platinum temperature sensor is brittle and can be broken if cleaning is not carefully performed. We recommend a spare heating element to avoid downtime with your stage while element is being repaired.

Part No.	Part Name	Part Description
22222	THMSG Kit	Full Replacement Spares Kit
	WGI	Water/Gas Valve Insert x2
	WVC	Water/Gas Valve Connector x2
	SRR	Silicon Rings for Lid and Base (Set of 4)
	TCH	Tube Clip Holder (for Nitrogen de-fogging stage lid tube)
	THMS/Q	15mm diameter Quartz Crucible for THMS/CC
	W7Q	7mm diameter Quartz Window (0.3mm thick) for use with G7T carrier x4
	W13G	Glass cover slips for SCO 16x0.15mm box of 50
	W22G	22x0.17mm Glass cover slips for stage top and bottom windows box of 50
	W22G0.3	22x0.3mm Glass cover slips box of 50
	G7T	Tapered 7mm Sample Carrier W7Q
	THMSG/CC	Crucible Carrier for THMS/Q with Spring Clips
	ORTHMSG	ORTHMS O-ring set for stage and lid
	TUBE	3x6x150mm Clear PVC Tube
	WT	Window Tool (for unlocking lid insert and base locking ring)
	SCO	22mm diameter Silver Cover Lid to fit on block for accurate temperature

Part No.	Part Name	Part Description
7501	THMSG Spare Windows Kit	Spare Windows for Lid, Base and samples
	THMS/Q	15mm diameter Quartz Crucible for THMS/CC
	W7Q	7mm diameter Quartz Window (0.3mm thick) x4
	W13G	Glass cover slips for SCO 16x0.15mm box of 50
	W22G	22x0.17mm Glass cover slips for stage top and bottom windows box of 50
	W22G0.3	22x0.3mm Glass cover slips box of 50
	SRR	Silicon Rings for Lid and Base (Set of 4)

Part No.	Part Name	Part Description
7502	W&S Kit	Precision Temperature Sample Window (not for use with polarised light work)
	W7S	7mm diameter Sapphire Sample Window (0.3mm thick) x20

Part No.	Part Name	Part Description
9580	THMSGB	Spare Silver Heating Element incl. Platinum Temperature Sensor

Part No.	Part Name	Part Description
2260	CSCO2	CO ₂ /H ₂ O Fluid Inclusions Standard (-56.6°C)

Part No.	Part Name	Part Description
0998	ECP	Water Circulator Pump (stage body and window cooling) (220-240V)
0997	ECP	Water Circulator Pump (stage body and window cooling) (110-130V)

Appendix

Troubleshooting

Cooling fault diagnosis

Ensure that all connections to the stage and Dewar are as described in the specific manual and that the stage lid and top windows are properly sealed.

1. *The cooling rate is less than programmed.*
There can be several causes of this problem, the most likely being that one of the connectors has become blocked or damaged. Check that each tube is fitted tightly to the connector and that none of the tubing is twisted or has come loose. The larger diameter tube leading from the LNP95 consists of a tube within a tube, check that the internal tube is connected, it may have come loose. Any constrictions of either the tubing or the connector will have a drastic effect on the cooling ability of the LNP95. If the connectors and tubing are OK, check that the capillary tubing to the Dewar flask is not bent or damaged and that the filter is intact and unblocked. If any damage has occurred to any of these items then it will be necessary to replace them. If no damage is found, check that the silver block is not constricted. This can be checked, simply by blowing through one of the steel cooling tubes using a compressed air line.
2. *Stage will not cool down to -196°C.*
Check that the stage lid is not touching the silver block when screwed down. Check that the silver block has not been pushed down so that it touches the base of the stage. Check the sample holder ramp is not touching the silver block. Any of these faults will cause a substantial loss of cooling ability.
3. *Condensation and ice forming on the upper side of window*
Realign the window gas tube clip to the required position in the stage lid.
4. *Condensation on the sample and/or the underside of lid window*
This is due to the stage not being sealed properly and therefore allowing moisture in during purging or cooling. Check that the lid and bottom window are sealed correctly and that the silicon seals are in position.

Please visit www.Linkam.co.uk for more FAQ for the stage and instruments.

This page is intentionally blank

This page is intentionally blank

This page is intentionally blank

